

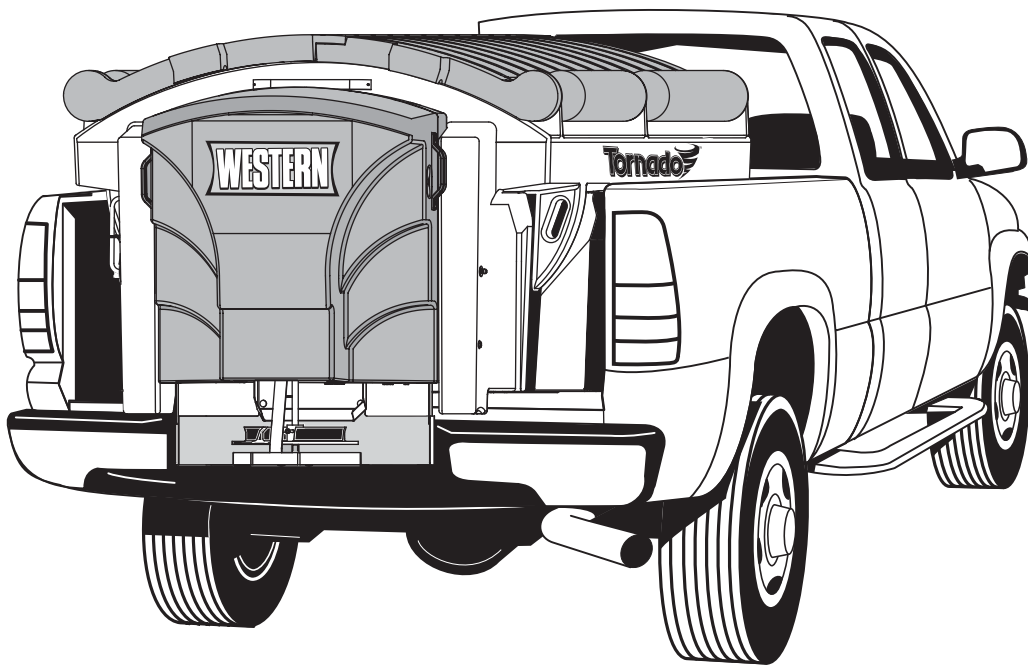

Tornado™ Hopper Spreader

#78000, 78003, 78006

Owner's Manual
Original Instructions



⚠ CAUTION

Read this document before operating
or servicing the spreader.

This manual is for WESTERN® Tornado Hopper Spreaders with serial numbers
beginning with 090527-120430.

This manual supersedes all editions with an earlier date.

TABLE OF CONTENTS

PREFACE	4	MOUNTING THE SPREADER	12
Owner's Information.....	4	OPERATING THE SPREADER – CAB CONTROL .	16
SAFETY	5	Starting and Stopping Motor.....	16
Safety Definitions.....	5	Adjusting Spinner/Conveyor Speed	16
Warning/Caution Labels	5	Blast/Maximum Speed.....	16
Serial Number Label	6	Diagnostic Indicator Light and Audio Beep.....	17
Safety Precautions.....	6	REMOVING THE SPREADER	18
Fuses	7	MAINTENANCE	19
Personal Safety.....	7	Grease Fittings	19
Fire and Explosion	7	Drive Belt and Chain Tension	19
Cell Phones.....	7	Conveyor Pintle Chain Tension.....	20
Ventilation	8	After Each Use.....	21
Battery Safety	8	Storage	21
Noise.....	8	At the End of Each Season or	
Vibration.....	8	After Extended Storage	22
Torque Chart.....	8	Fuse Replacement.....	22
LOADING	9	Recycle	22
Certification.....	9	Gear Oil Specification.....	22
Load Volume	9	HARNES WIRING DIAGRAM	23
Material Weights	9	TROUBLESHOOTING GUIDE	24
Spreader Specifications.....	10		
Determining Vehicle Payload.....	10		
Determining Vehicle Payload Worksheet.....	11		

PREFACE

This manual has been prepared to acquaint you with the safety information, operation and maintenance of your new hopper spreader. Please read this manual carefully and follow all recommendations. This will help ensure profitable and trouble-free operation of your hopper spreader. Keep this manual accessible. It is a handy reference in case minor service is required.

When service is necessary, bring your hopper spreader to your distributor. They know your spreader best and are interested in your complete satisfaction.

NOTE: This spreader is designed to spread snow and ice control materials only. Do not use it for purposes other than those specified in this manual.

Register your spreader online at www.westernplows.com

OWNER'S INFORMATION

Owner's Name: _____

Date Purchased: _____

Outlet Name: _____ Phone: _____

Outlet Address: _____

Vehicle Model: _____ Year: _____

Spreader Type (Model): _____ Serial #: _____

Length: _____ Weight: _____ lb/kg: _____

SAFETY

SAFETY DEFINITIONS

⚠ WARNING

Indicates a potentially hazardous situation that, if not avoided, could result in death or serious personal injury.

⚠ CAUTION

Indicates a potentially hazardous situation that, if not avoided, may result in minor or moderate injury. It may also be used to alert against unsafe practices.

NOTE: Indicates a situation or action that can lead to damage to your spreader and vehicle or other property. Other useful information can also be described.

WARNING/CAUTION LABELS

Become familiar with and inform users about the warning and caution labels on the spreader.

NOTE: If labels are missing or cannot be read, see your sales outlet.

⚠ CAUTION

Do not lift spreader by this member.
Lifting here could cause personal injury and property damage.

67272

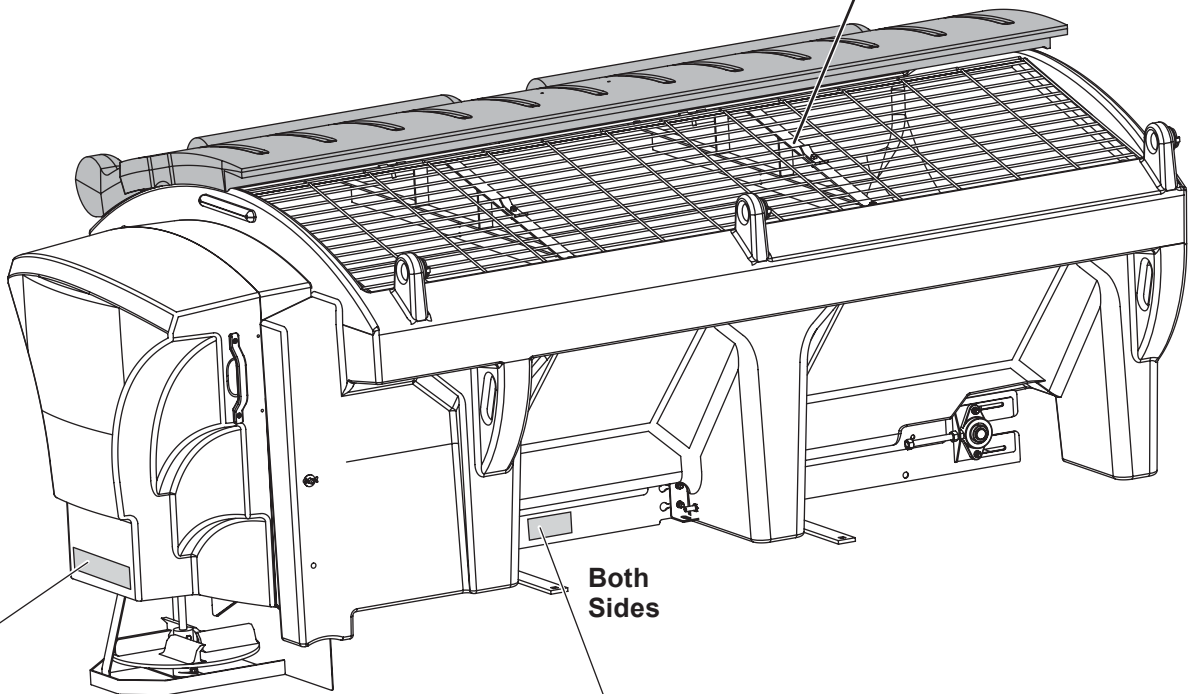

Both
Sides



⚠ WARNING

- DO NOT exceed GVWR or GAWR with spreader and load.
- Turn spreader OFF before filling, adjusting or cleaning.
- Bystanders to stay a minimum of 25 feet away from operating spreader.
- DO NOT climb into or ride on spreader.
- Keep hands, feet and clothing away from moving conveyor and spinner.



⚠ CAUTION

- Read Owner's Manual before operating or servicing spreader.
- Empty and clean spreader after every use.

68584

SAFETY

SERIAL NUMBER LABEL

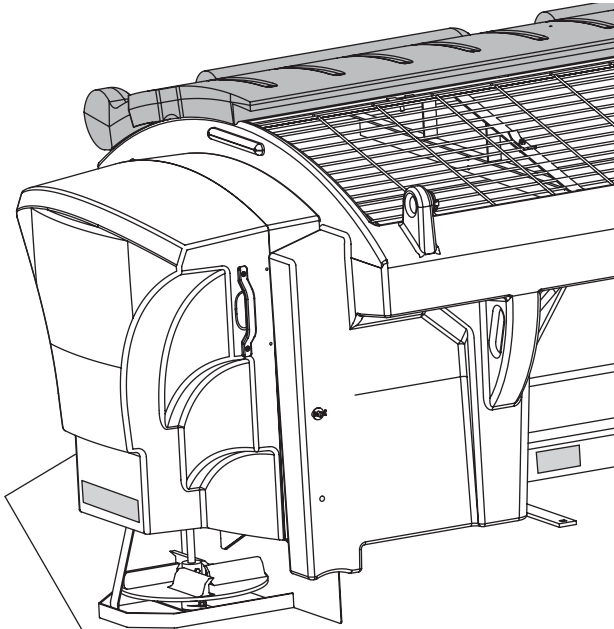

(Located on driver's side, next to warning/caution label.)

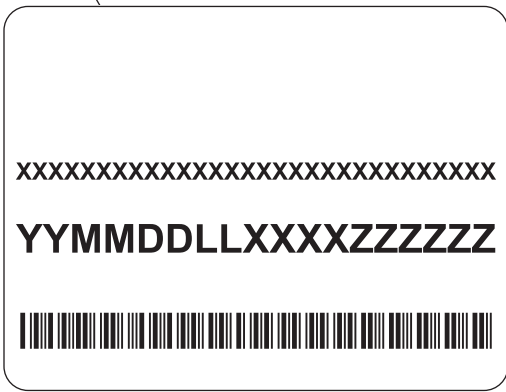

Code	Definition
YY	2-Digit Year
MM	2-Digit Month
DD	2-Digit Day
LL	2-Digit Location Code
XXXX	4-Digit Sequential Number
ZZZZZZ	5- to 7-Digit Assembly PN

SAFETY PRECAUTIONS

Improper installation and operation could cause personal injury and/or equipment and property damage. Read and understand labels and the Owner's Manual before installing, operating, or making adjustments.

⚠ WARNING

- Driver to keep bystanders minimum of 25 feet away from operating spreader.
- Before working with the spreader, secure all loose-fitting clothing and unrestrained hair.
- Before operating the spreader, verify that all safety guards are in place.
- Before servicing the spreader, wait for conveyor, auger, and spinner to stop.
- Do not climb into or ride on spreader.

⚠ WARNING

Overloading could result in an accident or damage. Do not exceed GVWR or GAWR ratings as found on the driver-side vehicle door cornerpost. See Loading section to determine maximum volumes of spreading material.

⚠ WARNING

Do not install the control for this product in the deployment path of an air bag. Refer to vehicle manufacturer's manual for air bag deployment area(s).

⚠ CAUTION

If rear directional, CHMSL light, or brake stoplights are obstructed by the spreader, the lights shall be relocated or auxiliary directional or brake stoplights shall be installed.

⚠ CAUTION

During the hopper installation we recommend the addition of an OSHA compliant Backup Alarm. This alarm is required for OSHA governed employers.

SAFETY

⚠ CAUTION

- Do not operate a spreader in need of maintenance.
- Before operating the spreader, reassemble any parts or hardware removed for cleaning or adjusting.
- Before operating the spreader, remove materials such as cleaning rags, brushes, and hand tools from the spreader.
- Before operating the spreader, read the engine owner's manual, if so equipped.
- While operating the spreader, use auxiliary warning lights, except when prohibited by law.
- Tighten all fasteners according to the Torque Chart. Refer to Torque Chart for the recommended torque values.

⚠ CAUTION

Disconnect electric and/or hydraulic power and tag out if required before servicing or performing maintenance.

⚠ CAUTION

 DO NOT leave unused material in hopper. Material can freeze or solidify, causing unit to not work properly. Empty and clean after each use.

NOTE: Lubricate grease fittings after each use. Use a good quality multipurpose grease.

FUSES

The electrical system contains several blade-style automotive fuses. If a problem should occur and fuse replacement is necessary, the replacement fuse must be of the same type and amperage rating as the original. Installing a fuse with a higher rating can damage the system and could start a fire. Fuse Replacement, including fuse ratings and locations, is located in the Maintenance section of this Owner's Manual.

PERSONAL SAFETY

- Remove ignition key and put the vehicle in park or in gear to prevent others from starting the vehicle during installation or service.
- Wear only snug-fitting clothing while working on your vehicle or spreader.
- Do not wear jewelry or a necktie, and secure long hair.
- Wear safety goggles to protect your eyes from battery acid, gasoline, dirt, and dust.
- Avoid touching hot surfaces such as the engine, radiator, hoses, and exhaust pipes.
- Always have a fire extinguisher rated BC handy, for flammable liquids and electrical fires.

FIRE AND EXPLOSION

⚠ WARNING

Gasoline is highly flammable and gasoline vapor is explosive. Never smoke while working on vehicle. Keep all open flames away from gasoline tank and lines. Wipe up any spilled gasoline immediately.

Be careful when using gasoline. Do not use gasoline to clean parts. Store only in approved containers away from sources of heat or flame.

CELL PHONES

A driver's first responsibility is the safe operation of the vehicle. The most important thing you can do to prevent a crash is to avoid distractions and pay attention to the road. Wait until it is safe to operate Mobile Communication Equipment such as cell phones, text messaging devices, pagers, or two-way radios.

SAFETY

VENTILATION

⚠ WARNING

Vehicle exhaust contains lethal fumes. Breathing these fumes, even in low concentrations, can cause death. Never operate a vehicle in an enclosed area without venting exhaust to the outside.

BATTERY SAFETY

⚠ CAUTION

Batteries normally produce explosive gases which can cause personal injury. Therefore, do not allow flames, sparks, or lit tobacco to come near the battery. When charging or working near a battery, always cover your face and protect your eyes, and also provide ventilation.

- Batteries contain sulfuric acid, which burns skin, eyes, and clothing.
- Disconnect the battery before removing or replacing any electrical components.

NOISE

Airborne noise emission during use is below 70 dB(A) for the spreader operator.









VIBRATION

Operating spreader vibration does not exceed 2.5 m/s² to the hand-arm or 0.5 m/s² to the whole body.

TORQUE CHART

⚠ CAUTION

Read instructions before assembling. Fasteners should be finger tight until instructed to tighten according to the Torque Chart. Use standard methods and practices when attaching spreader, including proper personal protective safety equipment.

Recommended Fastener Torque Chart					
Inch Fasteners Grade 5 and Grade 8					
Size	Torque (ft-lb)		Size	Torque (ft-lb)	
	 Grade 5	 Grade 8		 Grade 5	 Grade 8
1/4-20	8.4	11.9	9/16-12	109	154
1/4-28	9.7	13.7	9/16-18	121	171
5/16-18	17.4	24.6	5/8-11	150	212
5/16-24	19.2	27.3	5/8-18	170	240
3/8-16	30.8	43.6	3/4-10	269	376
3/8-24	35.0	49.4	3/4-16	297	420
7/16-14	49.4	69.8	7/8-9	429	606
7/16-20	55.2	77.9	7/8-14	474	669
1/2-13	75.3	106.4	1-8	644	909
1/2-20	85.0	120.0	1-12	704	995
Metric Fasteners Class 8.8 and 10.9					
Size	Torque (ft-lb)		Size	Torque (ft-lb)	
	 Class 8.8	 Class 10.9		 Class 8.8	 Class 10.9
M6 x 1.00	7.7	11.1	M20 x 2.50	325	450
M8 x 1.25	19.5	26.9	M22 x 2.50	428	613
M10 x 1.50	38.5	53.3	M24 x 3.00	562	778
M12 x 1.75	67	93	M27 x 3.00	796	1139
M14 x 2.00	107	148	M30 x 3.50	1117	1545
M16 x 2.00	167	231	M33 x 3.50	1468	2101
M18 x 2.50	222	318	M36 x 4.00	1952	2701
These torque values apply to fasteners except those noted in the instructions.					

LOADING

This Owner's Manual covers vehicles that have been recommended for carrying the hopper spreader. Please see your local dealer for proper vehicle applications.

CERTIFICATION

⚠ WARNING

New untitled vehicle installation of a spreader requires National Highway Traffic Safety Administration altered vehicle certification labeling. Installer to verify that struck load of snow or ice control material does not exceed GVWR or GAWR rating label and complies with FMVSS.

⚠ WARNING

Overloading could result in an accident or damage. Do not exceed GVWR or GAWR as found on the driver-side cornerpost of vehicle.

LOAD VOLUME

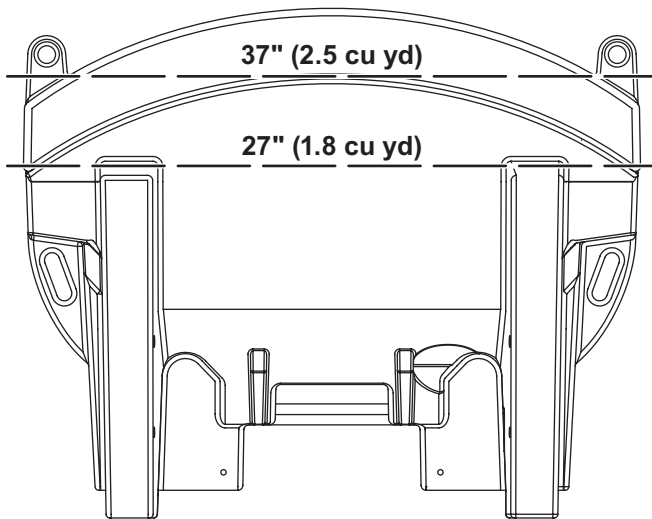

8' Unit

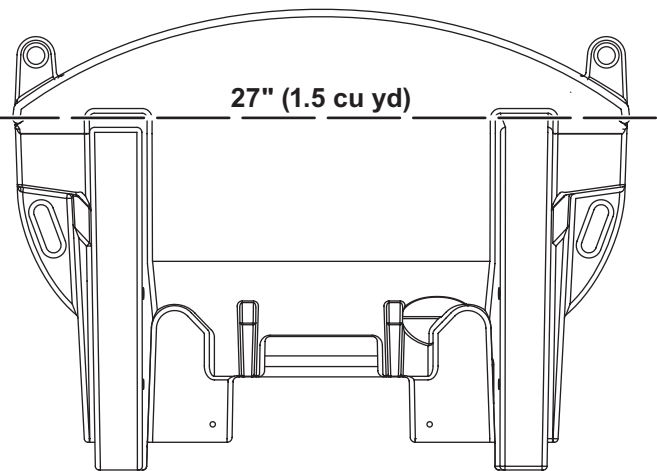

7' Unit

⚠ CAUTION



Read and adhere to manufacturer's ice-control material package labeling, including Material Safety Data Sheet requirements.

MATERIAL WEIGHTS

Material	Density		
	(lb/ft ³)	(lb/yd ³)	(kg/m ³)
Salt	80	2160	1282
Sand	100	2700	1602

Material densities are approximate and are based on dry, loose material. It is the responsibility of the operator to know the weight of the material to be spread and the vehicle carrying capacity.

LOADING

SPREADER SPECIFICATIONS

Spreader Description	Overall Length (in)	Empty Weight (lb)	Capacity Struck (cu yd)	Overall Width (in)	Overall Height (in)	Recommended Use
Regular Capacity 7' Hopper Body Double-Wall Poly	108	591	1.5	63	44	3/4–1 ton Pickup Trucks above 8500 lb GVWR
8' Hopper Body w/o Collar Double-Wall Poly	117	660	1.8	63	44	3/4–1 ton Pickup Trucks above 8500 lb GVWR
8' Hopper Body w/ Collar Double-Wall Poly	117	734	2.5	63	51	Dump Body – Flatbed

DETERMINING VEHICLE PAYLOAD

⚠ WARNING

Overloading could result in an accident or damage. Do not exceed GVWR or GAWR ratings as found on the driver-side door cornerpost of the vehicle. See Loading section to determine maximum volumes of spreading material.

1. Install the hopper spreader and optional equipment according to the instructions.
2. Install or attach any other equipment that will be on the vehicle while the hopper spreader will be in use (step bumper, trailer hitch, snowplows, etc.). Fill gas tanks.
3. Obtain the Gross Vehicle Weight Rating (GVWR), Front Gross Axle Weight Rating (FGAWR) and Rear Gross Axle Weight Rating (RGAWR) from the certification label located inside the driver-side door jamb or door.
4. With the occupants in the truck for normal hopper spreader operation, weigh the vehicle to obtain gross vehicle weight (GVW).
5. Subtract the GVW from the GVWR to determine the available material payload.
6. Obtain the weight per cubic yard (lb/cu yd) of the desired material. Divide the weight into the payload to determine the maximum volume of material that can be carried.
7. Compare the maximum volume to determine the maximum height of the material in the hopper spreader.
8. Fill the hopper with the material to the calculated height. Reweigh the vehicle with occupants and verify that the GVW, Front Gross Axle Weight, and Rear Gross Axle Weight are less than the vehicle's ratings.
9. Repeat Steps 6–8 for each type of material.

Refer to the "Determining Vehicle Payload Worksheet" for an example and worksheet.

LOADING

Determining Vehicle Payload Worksheet

Material Type	Example: Dry Salt				
Equipment installed when vehicle was weighed	7' Poly Hopper Spreader				
Front Gross Axle Weight Rating (FGAWR) (lb)					
Rear Gross Axle Weight Rating (RGAWR) (lb)					
Gross Vehicle Weight Rating (GVWR) (lb)	8600				
Gross Vehicle Weight (empty) (lb)	- 6500				
Payload Available (lb)	= 2100				
Material Density (lb/cu yd)	÷ 2160				
Maximum Volume (cu yd)	= 0.97				
Maximum Height (approximate) (in)	18				
Loaded Front Gross Axle Weight (FGAW) (lb)					
Loaded Rear Gross Axle Weight (RGAW) (lb)					
Loaded Gross Vehicle Weight (GVW) (lb)					

MOUNTING THE SPREADER

NOTE: Periodically throughout the snow and ice control season, verify that mounting devices are secure.

CAUTION

Before lifting, verify that hopper is empty of material. The lifting device must be able to support the spreader's weight as shown in the spreader specifications table.

1. Remove the chute from the inside of the hopper:
 - a. Unlatch the rubber straps located at the rear of the lids near the handles.
 - b. Remove the screens.
 - c. Remove the screen supports.
 - d. Remove the chute and replace the screen supports and screens.
 - e. Close the lids and latch the rubber straps.
2. Remove the tailgate from the truck.

3. Attach the truck mounting bars to the sill brackets:
 - a. Measure the width between the wheel wells.
 - b. If needed, cut one or both of the supplied bars to the correct length.
 - c. Attach them to the sill brackets using the supplied hardware as shown.

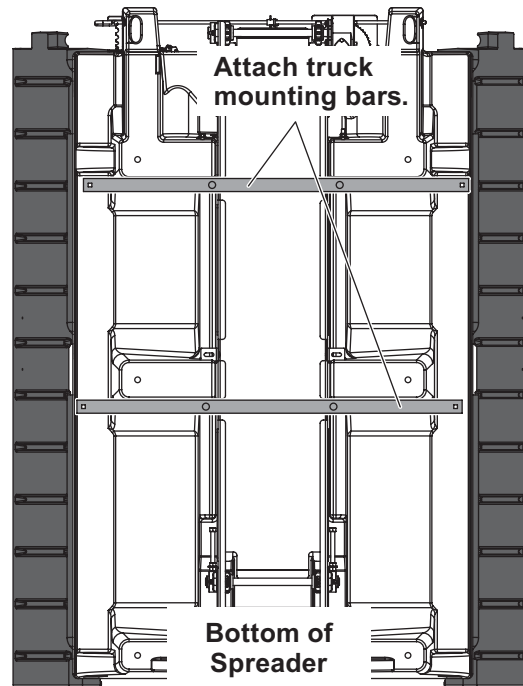

4. The spreader can be moved into the truck bed either by lifting the spreader by the four molded-in handles located on the corner legs or by sliding the spreader into the truck bed from the ground.

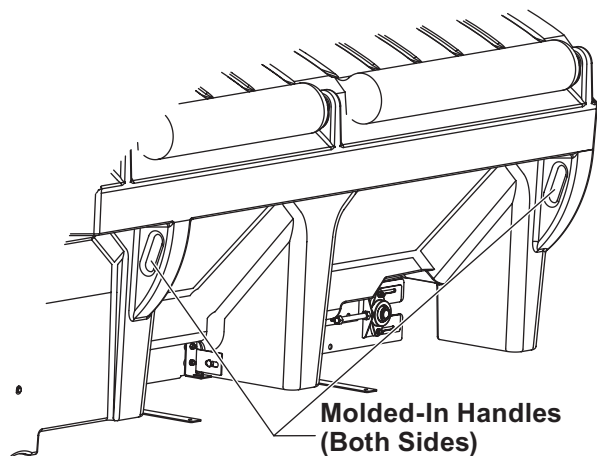

MOUNTING THE SPREADER

- To lift the spreader into the truck bed from the ground, stand the spreader up on the feet at the rear of the spreader on top of two spacers at least 2" off the ground. The chute must be removed.

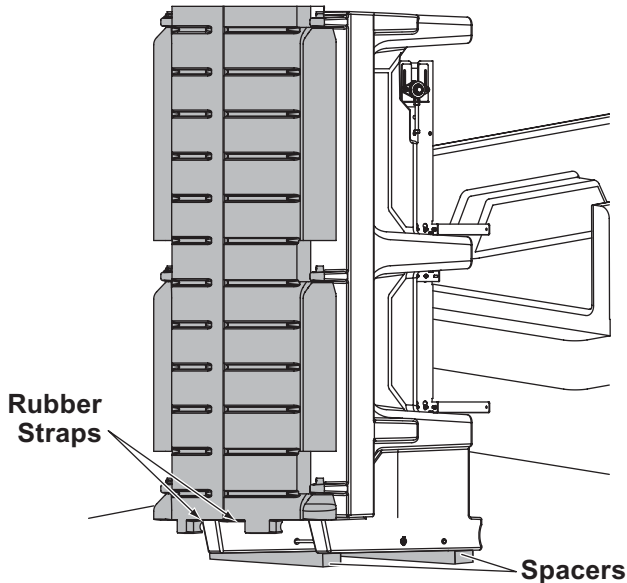

- Position spreader on its feet at the rear of the truck.
- Tip the spreader toward the truck until the sill rests on the rear edge of the truck bed.
- Lift the rear of the spreader and slide it into the truck bed. Two or more people are recommended for this task.
- Center the spreader in the truck.
- Remove the cable tie holding the wire harness to the conveyor chain. Connect the vehicle side harness to the hopper side harness.

- Assemble the material deflectors to the sill.
 - Loosen both carriage bolts for the bearing and the last two cap screws for the gear box.

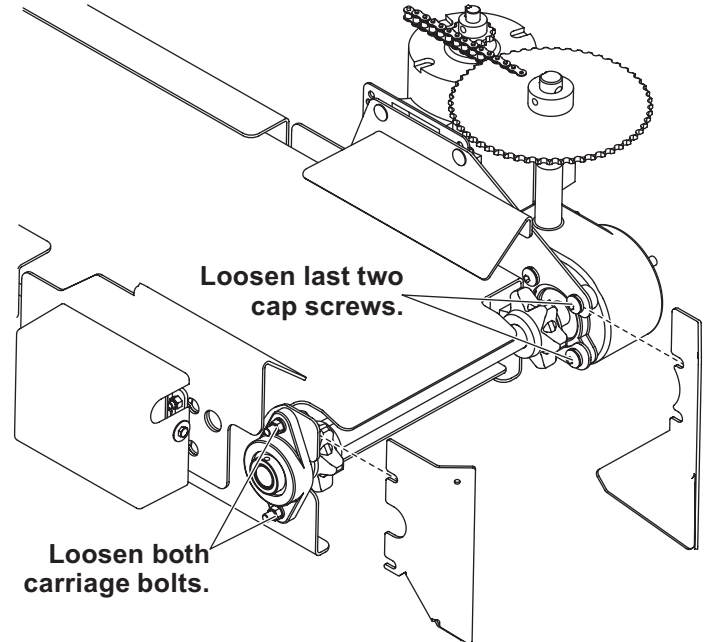

- Slide the deflectors into place between the sill and the fastener heads.
- Tighten all of the fasteners according to the torque chart.

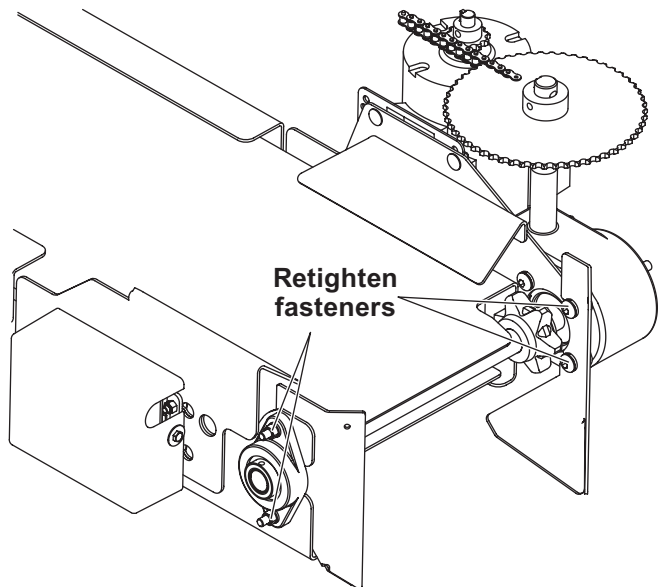

NOTE: The deflectors must be removed if you are going to store the unit vertically.

MOUNTING THE SPREADER

12. To assemble the chute to the spreader:

- a. Select the height for the chute assembly. The upper chute position (using lower two slots) is typically used for pickup truck installations.
- b. Remove the extended deflector if used in the upper position.
- c. Lift the chute onto the feed gate actuator bar and slide it down into place.
- d. Align the holes in the hopper body with the threaded inserts in the chute, and install the pins to secure the chute to the hopper body.
- e. Connect the spinner motor wiring harness.

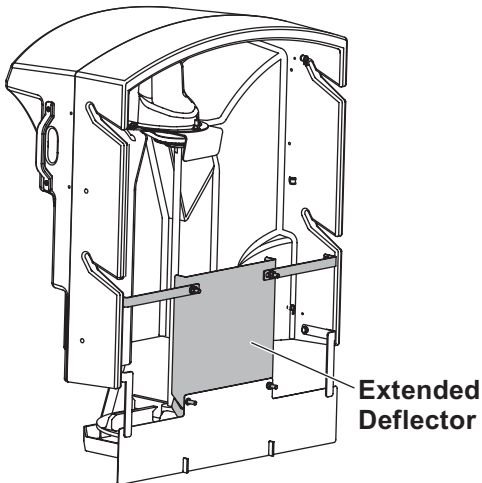

13. Install the spacer between the end of the sill and the front of the truck bed as shown. If you do not have a spacer, refer to the Installation Instructions to create one. ***Failure to install this spacer could result in damage to the spreader.***

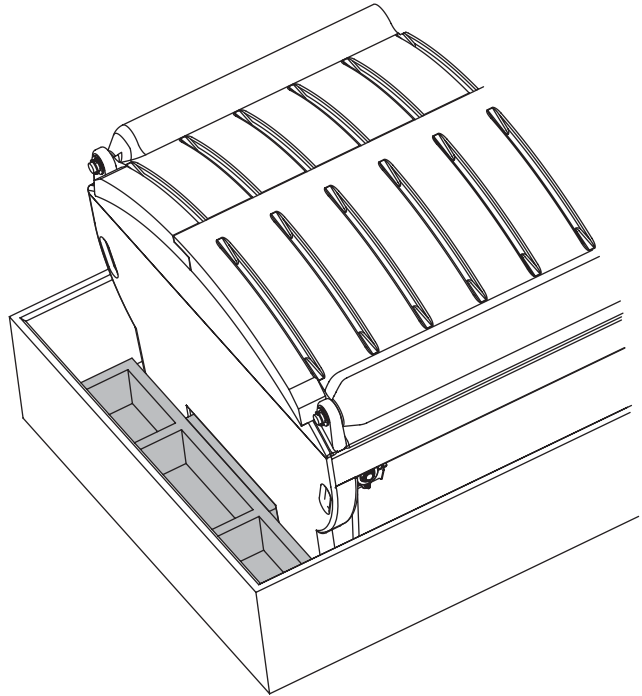

MOUNTING THE SPREADER

⚠ WARNING

Spreader shall be bolted to vehicle frame.
Do not rely on the tie-down chains or straps
alone to hold spreader in vehicle.

⚠ CAUTION

Before drilling any holes, check both sides
of the material for any wires, fuel lines, fuel
tanks, etc., that may be damaged by drilling.

14. Fasten the spreader to the truck frame using the mounting bars and existing holes and hardware. If there are no holes, refer to the Installation Instructions.

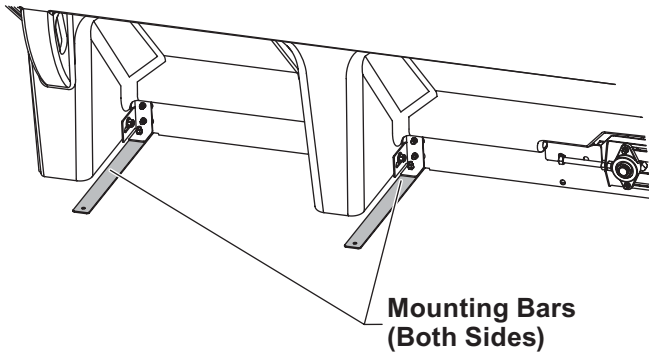

NOTE: Pay special attention when drilling or clamping dissimilar metals to aluminum bodies. Galvanic corrosion can occur if not handled properly. Contact vehicle manufacturer for recommended attachment practices.

OPERATING THE SPREADER – CAB CONTROL

⚠ WARNING

Never operate equipment when under the influence of alcohol, drugs, or medications that might alter your judgment and/or reaction time.

⚠ WARNING

Never exceed 45 mph (72 km/h) when loaded spreader is attached to vehicle. Braking distances may be increased and handling characteristics may be impaired at speeds above 45 mph (72 km/h).

⚠ WARNING

Never allow children to operate or climb on equipment.

⚠ WARNING

Before starting the spreader, the driver shall verify that all bystanders are a minimum of 25 feet away from operating spreader.

STARTING AND STOPPING MOTOR

1. To start the spreader, press the START/BLAST button and release. Both the START/BLAST and OFF buttons will be backlit when vehicle ignition is ON. When the spreader is ON the lights around the knobs will be lit up.

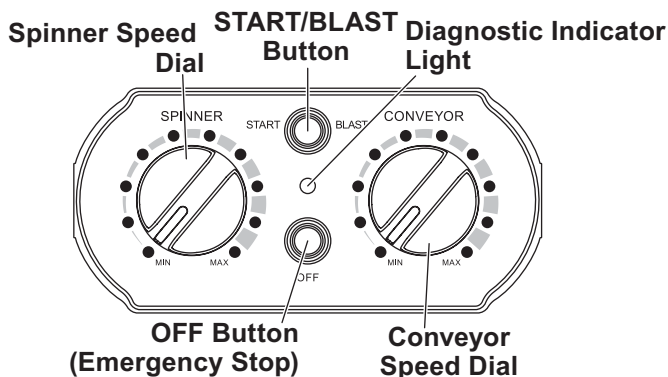

2. Press the OFF button to stop the spreader.

The OFF button operates as an emergency stop when required.

NOTE: The truck ignition must be ON to start the spreader.

NOTE: If truck ignition is turned OFF while spreader is running, the motors will stop.

ADJUSTING SPINNER/CONVEYOR SPEED

The speed setting can be adjusted when spreader is either ON or OFF.

1. Turn speed dial clockwise. Speed will increase as the number of green LEDs illuminated on speed dial increases.
2. Turning speed dial counterclockwise will decrease speed.

Blast/Maximum Speed

1. Press and hold START/BLAST button as long as maximum speed is needed.
2. Release button when maximum speed is no longer needed. The control automatically returns to the "ON" position and the speed shown on the speed dial.

NOTE: When blast is used, the speed dial does not move to the maximum speed setting, but remains at the preset speed.

OPERATING THE SPREADER – CAB CONTROL

DIAGNOSTIC INDICATOR LIGHT AND AUDIO BEEP

The diagnostic indicator light located to the right of the START/BLAST button remains dark unless a problem with the motor or wiring is detected. The light will flash in coordination with an audio beep a number of flashes/beeps in a row, pause, then repeat. Count the flashes/beeps to determine the nature of the malfunction and refer to diagnostic chart below.

NOTE: Always close the lids on the hopper to prevent moisture buildup. Do not let spreader sit idle with material in the hopper for an extended period of time. This can cause material to compact, reduce or stop the flow of material, and cause permanent hopper body deformation.

# of Flashes/Beeps	Problem	Possible Cause
0	No Error	–
1	No Communication	Loss of communication between spreader module and cab control. Vehicle battery cable is disconnected or faulty.
2	Empty Hopper	Spreader is empty or material has bridge in the hopper.
3	Conveyor Over Current	Over 70 amps for up to 3 seconds. Conveyor chain is stalled.
4	No Power	Battery fuse is blown or vehicle battery cable is disconnected or faulty.
5,8	Over Temp	Motor is OFF due to spreader module overheating from high-current draw over a long period of time.
6	Battery Saver	Reduced spreader performance due to vehicle voltage drop. Spreader will function at reduced output until vehicle voltage increases.
7	Spinner Over Current	Over 32 amps for up to 3 seconds. Spinner is stalled.
9	Sander Reset	Module came out of reset. Momentary loss of power. Restart unit, check power wiring.
10	Cool Down	If the unit gets more than 5 faults with each fault starting within 60 seconds from the last, it will not start for 60 seconds from the last fault to allow the unit to cool.
11	Low Battery	Low battery voltage or poor electrical connection of vehicle battery cable.

REMOVING THE SPREADER

⚠ CAUTION

Before lifting, verify hopper is empty of material. The lifting device must be able to support the spreader's weight as shown in the spreader specifications table.

1. The spreader can be removed from the truck bed either by lifting the spreader by the four molded-in handles located on the corner legs or by sliding the spreader out of the truck bed onto the ground.
2. To remove the spreader from the truck without a lifting device, first make sure all material has been removed from the spreader and the chute is detached. To empty the spreader and remove the chute:
 - a. Remove the two pins that hold the chute to the hopper body.
3. Disconnect the electrical connections at the spreader.
4. Remove any means used to attach the spreader to the truck bed and ensure the lids are closed securely.

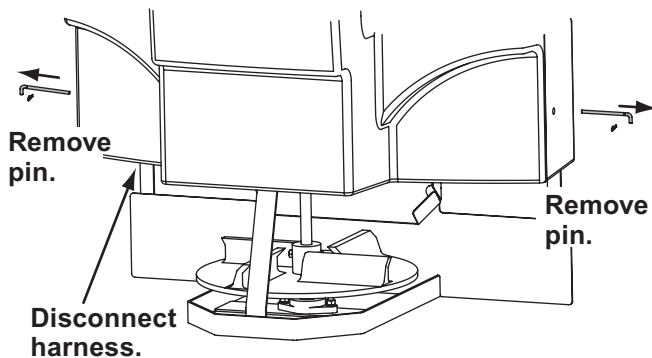

- b. Disconnect the spinner motor connector.
- c. Grasp the chute, raise it and remove it from the hopper body.
- d. Operate the hopper to convey all material from the spreader.
- e. Remove the sill deflectors by loosening the bolts for the bearing and gear box. Slide out the deflectors and tighten bolts.

5. To remove the spreader without a lifting device, two or more people are recommended. Move spreader rearward until it balances at the rear of the bed. Carefully lower the back of the spreader to the ground so it is resting on its feet.
6. Tip the spreader up onto spacers at least 2" tall, so it is fully supported by the feet.

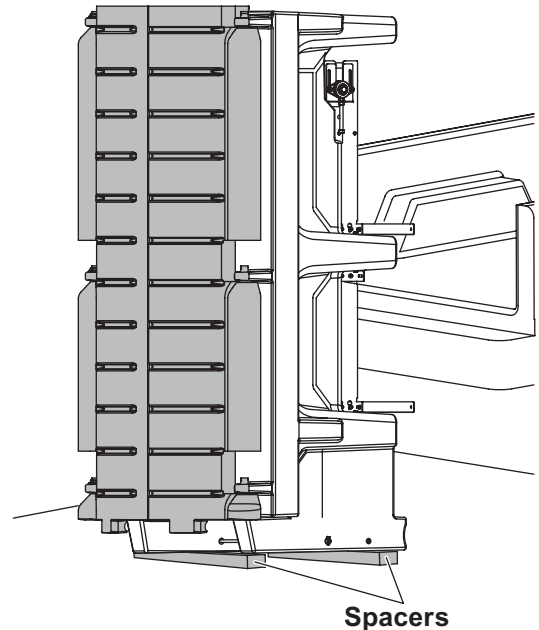

7. **Do not leave an unsecured spreader standing on its feet.** After pulling the truck away, either lower the spreader so it is resting on its 6 legs or properly support it with blocks and secure it as directed under "Storage" in the Maintenance section of this manual. If lowering the spreader onto its 6 legs, place spacers under the legs so the feet at the rear of the spreader are off the ground.

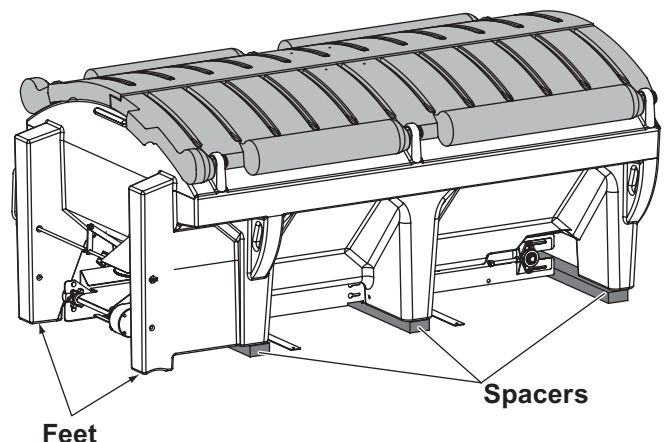

MAINTENANCE

⚠ CAUTION

Disconnect electric power at spreader electrical wiring harness connection and tag out if required before servicing or performing maintenance.

GREASE FITTINGS

To keep your spreader running smoothly, observe the following recommendations:

- Lubricate grease fittings after each use and at the end of each season.

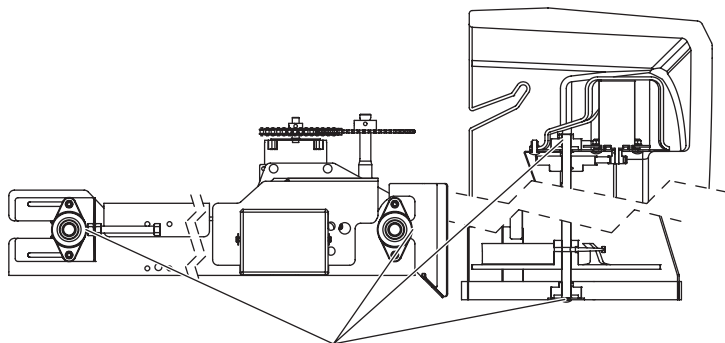

Grease after each use with a good quality multipurpose grease.

DRIVE BELT AND CHAIN TENSION

To adjust belt tension:

1. Remove the chute from the hopper.
2. Remove the five bolts that hold the motor cover in place. Disconnect the wires and remove the cover.
3. Replace two of the bolts on opposite corners of the motor to secure the base plate to the chute.
4. Loosen the four bolts that secure the motor mount plate to the base plate.
5. Slide the motor until the proper tension of the drive belt (when it is easily deflected 1/4") is achieved.

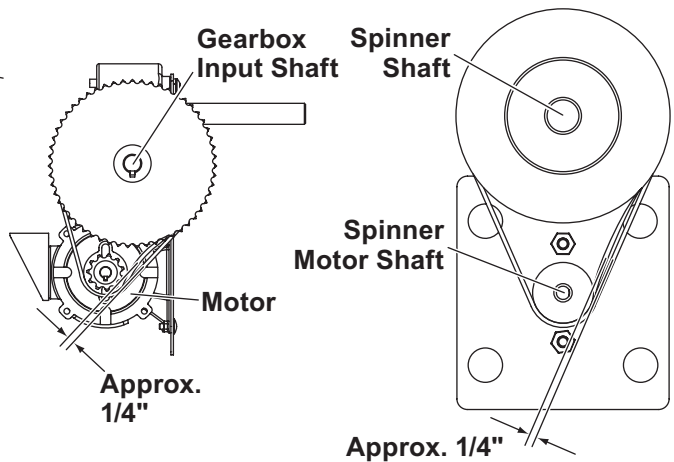

MAINTENANCE

6. Tighten the four motor mount plate bolts.
7. Verify the belt tension. The belt should easily deflect 1/4" when it is properly tightened.
8. Remove the two bolts holding the base plate to the chute and replace the cover.
9. Tighten the five bolts to proper torque and reconnect the motor wires.
10. Verify the belt tension. The belt should easily deflect 1/4" when it is properly tightened.

NOTE: Overtightening the belt or chain may result in damage to the motor or gear box bearing.

To adjust the chain tension:

1. Loosen the bolts that hold the drive motor.
2. Slide the motor to increase or decrease the chain tension.
3. After adjusting the motor, tighten the bolts. The chain should deflect 1/4" between the sprockets.

CONVEYOR PINTLE CHAIN TENSION

1. Periodically check the conveyor chain tension. The spreader should be out of the vehicle. To check the tension, measure in 20"–24" from the rear edge of the sills. Push up on the chain with your hand. The conveyor chain should lift up 1"–3" off the conveyor chain guide.
2. If the slack is greater than 3", loosen the two bearing mounting bolts on each side of the conveyor idle roller on cab end of hopper.
3. Loosen the jam nut on one of the take-up bolts, then tighten (clockwise) the take-up bolt one full revolution. Retighten jam nut. Repeat evenly on the other side.

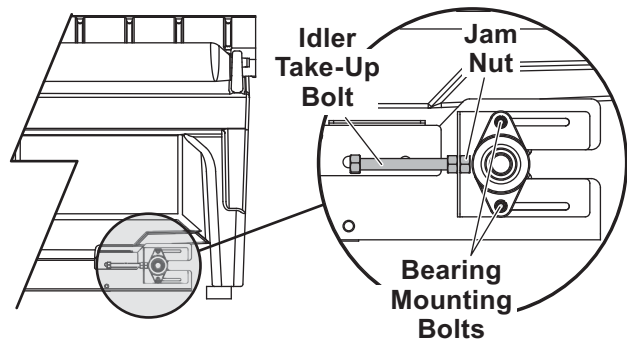

MAINTENANCE

AFTER EACH USE

- Wash out the hopper and rinse off all external surfaces.
- Clean out any trapped/frozen material from between the pintle chain and the vehicle bed surface.
- Apply dielectric grease on all electrical connections to prevent corrosion at the beginning and end of the season and after each use.
- Lubricate all grease fittings with good quality multipurpose grease.

STORAGE

The spreader can be stored on end (on its feet) for storage; however, steps must be taken to properly support it with blocks and secure it.

1. Remove the sill deflectors by loosening the bolts for the bearing and cap screws for the gear box. Slide out the deflectors and tighten the fasteners.
2. Back the truck near a wall, fence or other permanent structure so that there is enough room to remove the spreader but the spreader will be against the structure when it is taken out of the truck.
3. Remove the spreader from the truck following the instructions in this manual.
4. Add blocks supporting the sides of the hopper body and conveyor, as shown.

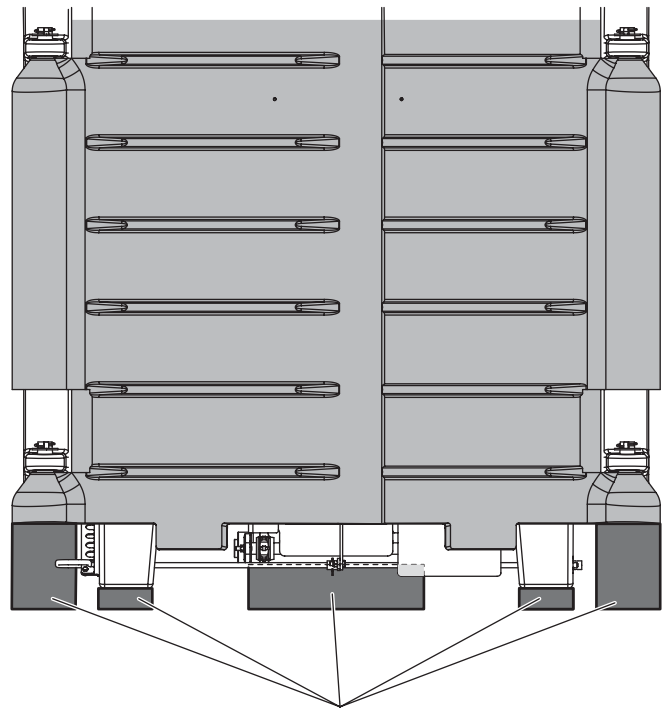

Support sides and conveyor with blocks.

MAINTENANCE

5. Secure the spreader to the structure using chains or straps to ensure that it cannot tip or fall.

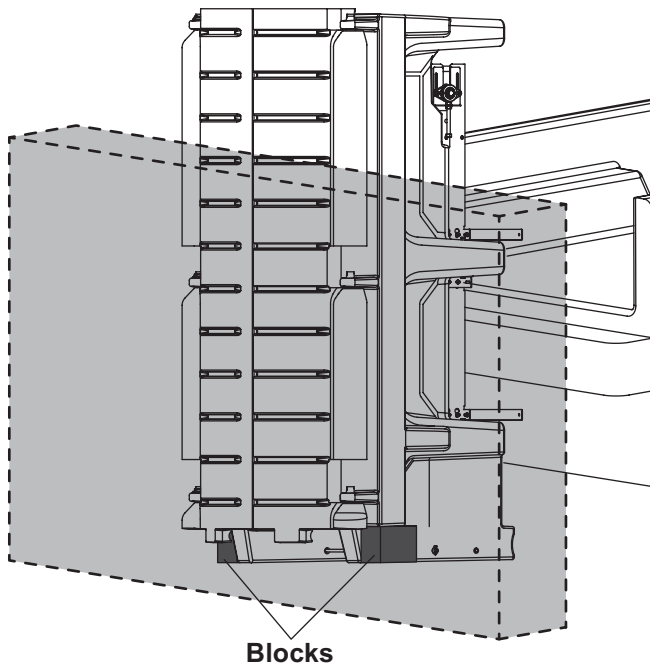

At the End of Each Season or After Extended Storage

- Wash out the hopper and rinse off all external surfaces.
- Apply dielectric grease on all electrical connections to prevent corrosion.
- Lubricate all grease fittings with good quality multipurpose grease.
- Oil or paint all bare metal surfaces.

FUSE REPLACEMENT

See the Harness Wiring Diagram for fuse locations.

If a problem should occur and fuse replacement is necessary, the replacement fuse must be of the same type and amperage rating as the original. Installing a fuse with a higher rating can damage the system and could start a fire.

RECYCLE

When your spreader has performed its useful life, many of its components can be recycled as steel. Gear oil shall be disposed of according to local regulations. Balance of parts made of plastic shall be disposed of in customary manner.

GEAR OIL SPECIFICATION

Use Mobil SHC 632 or Exxon SHP 320 or equivalent.

HARNESS WIRING DIAGRAM

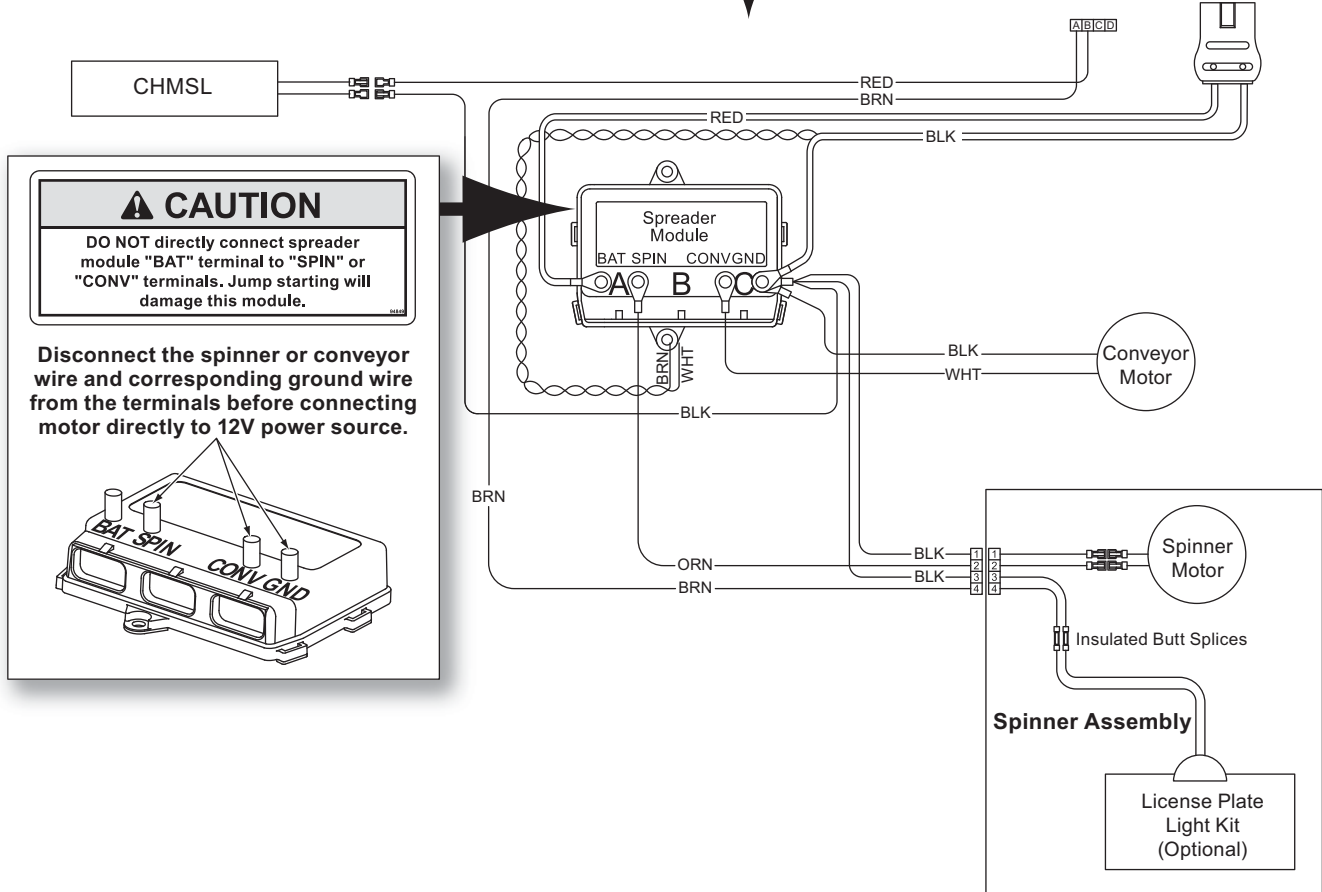
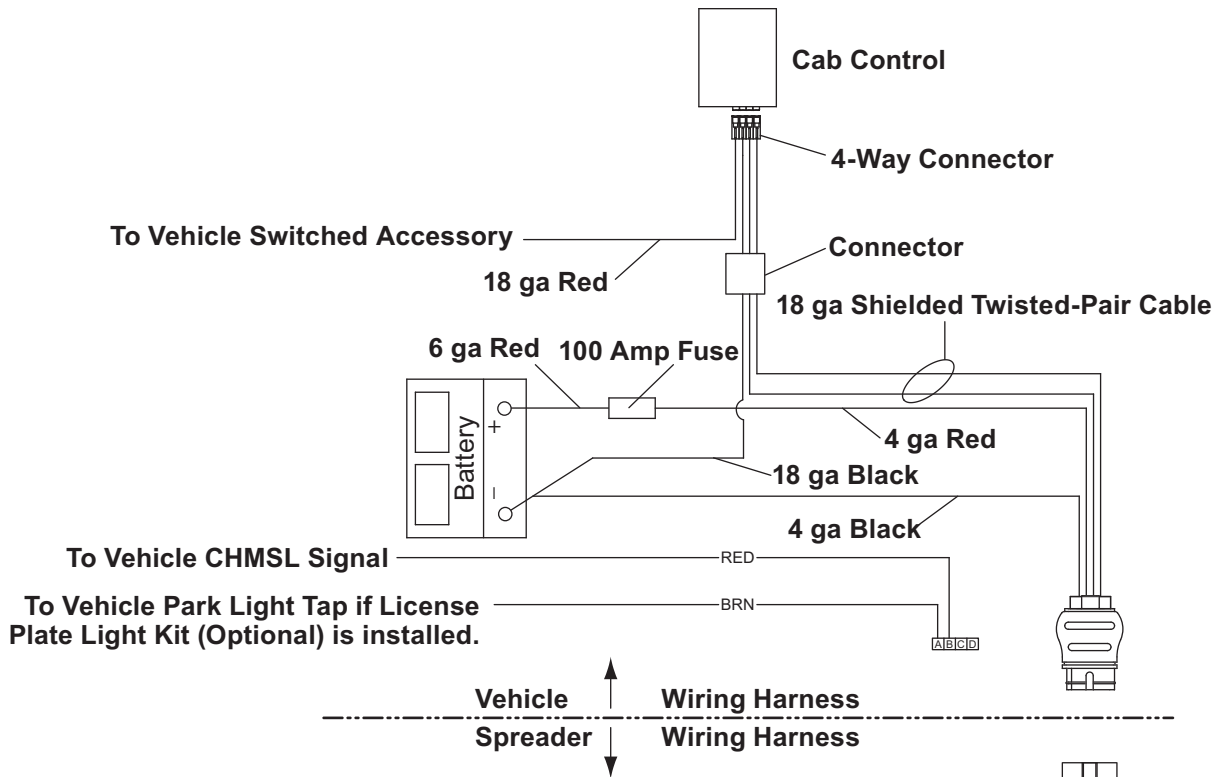

TROUBLESHOOTING GUIDE

Please see your distributor for service. The troubleshooting reference table below may guide you in diagnosing the issue.

For a reference table of the cab control error codes, see the "Operating the Spreader – Cab Control" section of this manual.

Before servicing the spreader:

- Review all safety information.
- Confirm that all electrical connections are tight and clean.
- Confirm that nothing is jammed in the hopper.

Problem	Possible Cause	Suggested Solution
No power to cab control. Ignition and control switches ON; no illumination of indicator light(s).	1. Control connector plug is loose.	1. Check plug connection at cab control.
	2. Switched accessory connection is poor or faulty battery.	2a. Check for low battery. 2b. Check switched accessory connection.
	3. Vehicle control harness is damaged.	3. Repair or replace damaged wires or harness as required.
Speed control dial does not change motor speed.	1. Malfunctioning cab control.	1. Replace cab control.
	2. Malfunctioning spreader module.	2. Replace spreader module.
Spreader does not operate. Indicator light(s) illuminated.	1. Overloaded condition is causing over-current protection to activate.	1. Reset cab control by turning the power OFF. Depress the START/BLAST switch to resume operation.
	2. Wire harness is damaged or has an open circuit between cab control and spreader.	2a. Check plug connections at cab control and spreader. 2b. Check wire connections at spreader motor and at vehicle battery – disconnect motor leads, turn control on, set cab control to maximum on variable speed controls and check for voltage at motor leads. 2c. Repair or replace damaged wires and connectors. 2d. Check the 100 amp in-line fuse. Replace if necessary.
Spinner does not turn. Motor is running.	Unplug the spreader harness and tag out, if required, before performing any of the following repairs.	
	1. Obstruction is preventing rotation.	1. Clear obstruction.
	2. Drive belt is loose or damaged.	2. Adjust the tension or replace the belt if worn or damaged.
	3. Motor pulley not secured to motor shaft.	3. Tighten the pulley set screw or replace the pulley if damaged.
	4. Spinner pulley is not secured to spinner shaft.	4. Tighten the pulley set screw or replace the pulley if damaged.
	5. Spinner shaft bearings are dry or seized.	5. Grease or replace bearings.

TROUBLESHOOTING GUIDE

Problem	Possible Cause	Suggested Solution
Conveyor chain not moving. Spinner is turning.	Unplug the spreader harness and tag out, if required, before performing any of the following repairs.	
	1. Obstruction is preventing rotation.	1. Clear obstruction.
	2. Sprocket is not secured to motor shaft.	2. Replace set screw if missing or damaged. Replace sprocket if damaged.
	3. Sprocket is not secured to gear box shaft.	3. Replace damaged or missing key. Replace sprocket if damaged.
	4. Gear box is damaged.	4. Replace gear box if output shaft does not turn when input shaft turns.
	5. Conveyor sprockets are not secured to shafts.	5. Replace missing cap screws and nuts. Replace shafts or sprockets if damaged.
	6. Conveyor pintle chain is loose or damaged.	6. Adjust pintle chain tension. Replace pintle chain if damaged.
	7. Conveyor pintle chain is not aligned.	7. Align pintle chain to ride centered on rollers.
	8. Conveyor pintle chain shaft bearings are seized or otherwise damaged.	8. Grease or replace bearings.
Material in hopper does not flow. Conveyor pintle chain and spinner are moving.	Unplug the spreader harness and tag out, if required, before performing any of the following repairs.	
	1. Feed gate is closed.	1. Open feed gate fully, then adjust to desired opening size.
	2. Obstruction in hopper.	2. Clear obstruction.
	3. Material bridged.	3. Clear the bridge.

This page intentionally left blank.



Western Products
PO Box 245038
Milwaukee, WI 53224-9538
www.westernplows.com

 A DIVISION OF DOUGLAS DYNAMICS, LLC

Copyright © 2017 Douglas Dynamics, LLC. All rights reserved. This material may not be reproduced or copied, in whole or in part, in any printed, mechanical, electronic, film or other distribution and storage media, without the written consent of Western Products. Authorization to photocopy items for internal or personal use by Western Products outlets or spreader owner is granted.

Western Products reserves the right under its product improvement policy to change construction or design details and furnish equipment when so altered without reference to illustrations or specifications used. Western Products or the vehicle manufacturer may require or recommend optional equipment for spreaders. Do not exceed vehicle ratings with a spreader. This product is manufactured under the following U.S. patents: 7,400,058; 7,737,576. Western Products offers a limited warranty for all spreaders and accessories. See separately printed page for this important information. The following are registered (®) or unregistered (™) trademarks of Douglas Dynamics, LLC: Tornado™, WESTERN®.

Printed in U.S.A.