



# Snowplow Installation Instructions

**⚠ CAUTION**

Read this document before installing the snowplow.

**⚠ CAUTION**

See your WESTERN® outlet for application recommendations. The Selection List has specific vehicle and snowplow requirements.

This document supersedes all editions with an earlier date.



---

# TABLE OF CONTENTS

---

## SAFETY

General Safety .....	1
Battery Safety .....	1
Torque Chart .....	1

## MOUNT INSTALLATION

A-Frame .....	2
Rubber Flap .....	3
Stand .....	3
Lift Frame .....	4
Center Deflector .....	4
Rubber Deflector .....	4
Blade Guide Assembly .....	6
Lift Channel, Hydraulic Unit, Hydraulic Fittings & Hoses Assembly .....	6
Light Bracket/Headlamps Assembly .....	10
Hydraulic Unit Wiring Assembly .....	10
Battery Cable Assembly .....	12
Vehicle Harness and Cable Installation .....	13
Mounting the CabCommand Hand-Held Control .....	16
Headlamp Harness Installation .....	16

## OPERATIONAL TEST AND ADJUSTMENTS

Filling the Hydraulic Unit .....	17
Blade Drop Speed Adjustment .....	18
Final Inspection .....	18
Coupling Lug Height Check .....	18
Vehicle Lighting Check .....	19



# SAFETY

## GENERAL SAFETY

Read these installation instructions and the labels on the snowplow before installing or operating the snowplow.

### WARNING

Indicates a potentially hazardous situation that, if not avoided, could result in death or serious personal injury.

### CAUTION

Indicates a situation that, if not avoided, could result in damage to product or property.

**NOTE:** Identifies tips, helpful hints and maintenance information the owner/operator should know.

### CAUTION

Refer to the current selection list for minimum vehicle recommendations and ballast requirements.

### CAUTION

Read instructions before assembling. Bolts should be finger tight until instructed to tighten according to the torque chart. Use standard methods and practices when attaching snowplow including wearing safety glasses during cutting, drilling and welding.

## BATTERY SAFETY




### CAUTION

Batteries normally produce explosive gases, which can cause personal injury. Therefore, do not allow flames, sparks or lit tobacco to come near the battery. When charging or working near a battery, always cover your face and protect your eyes, and also provide ventilation.

Batteries contain sulfuric acid that burns skin, eyes and clothing.

Disconnect the battery before removing or replacing any electrical components.

## TORQUE CHART

Recommended Fastener Torque Chart (Ft.-Lb.)			
Size	 SAE Grade 2	 SAE Grade 5	 SAE Grade 8
1/4-20	6	9	13
5/16-18	11	18	28
3/8-16	19	31	46
3/8-24	24	46	68
7/16-14	30	50	75
1/2-13	45	75	115
9/16-12	66	110	165
5/8-11	93	150	225
3/4-10	150	250	370
7/8-9	202	378	591
1-8	300	583	893
Metric Grade 8.8 (Ft.-Lb.)			
Size	Torque	Size	Torque
M 6	7	M 12	60
M 8	17	M 14	95
M 10	35	M 16	155
These torque values apply to mount assembly fasteners except those noted in the instruction.			

# INSTALLATION INSTRUCTIONS

## A-FRAME

1. Lay both wings face down (on cardboard) next to each other.
2. Push the blade wings together so that the holes in the hinges are aligned. (See Figure 1.)
3. Insert the A-frame hinges between the blade wings so that the holes in the A-frame hinges are aligned with the blade wing hinges. (See Figure 1.)
4. Insert the pivot pin through the hinges of the blade wings and the A-frame. (See Figure 1.)

**NOTE: Greasing the pin before inserting it, rotating the A-frame from side to side, and lifting the blade wing ends off the floor will help to insert the pin.**

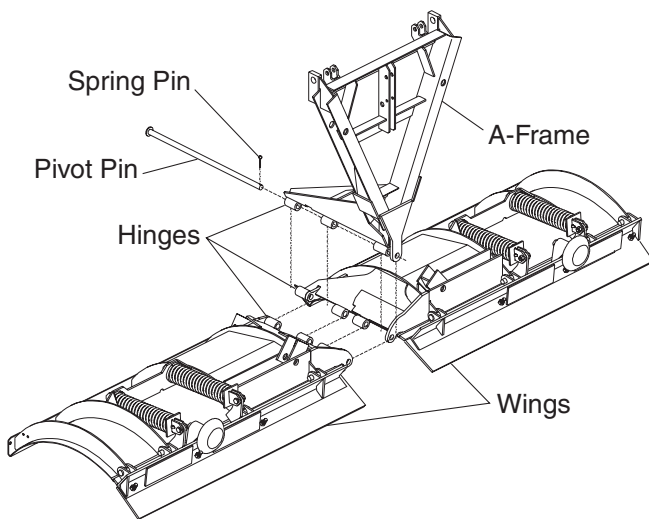


Figure 1

5. Install a 1/4" x 2" spring pin after inserting the pivot pin through all the hinges.
6. Position the rod ends of the two rams (found in hydraulics box) to the brackets on each of the blade wings.  
Secure the rod end of each ram to the blade with a 1" x 4" rivet installed from the top down and a 5/32" cotter pin.

7. Swing the A-frame to one side.  
Verify the threaded ports are facing away from the A-frame and position the base end of a ram into the channel on the side of the A-frame.  
Insert 1" x 4" rivet from the top down and secure with a cotter pin. Remove the pipe plugs from the threaded ports.
8. Swing the A-frame to the other side and repeat step 7 to connect the other ram to the A-frame.
9. Insert the 3/8" x 1-1/2" U-bolt through the end link of the chain.  
Insert the ends of the U-bolt into the holes in the nose plate of the A-frame and secure with locknuts. (See Figure 2.)

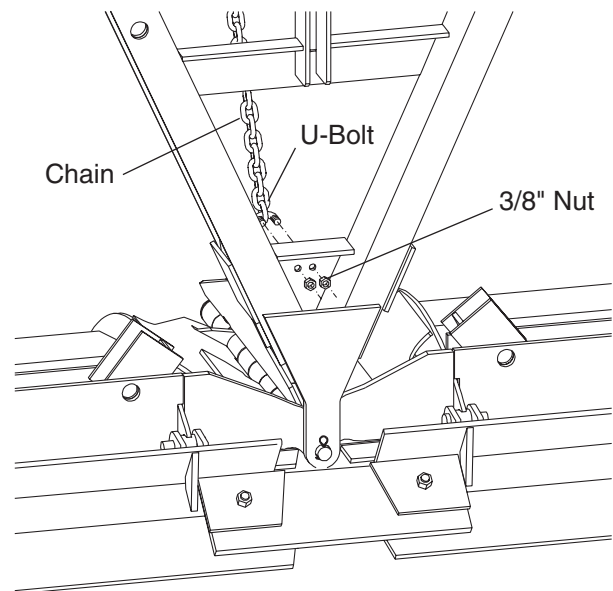


Figure 2

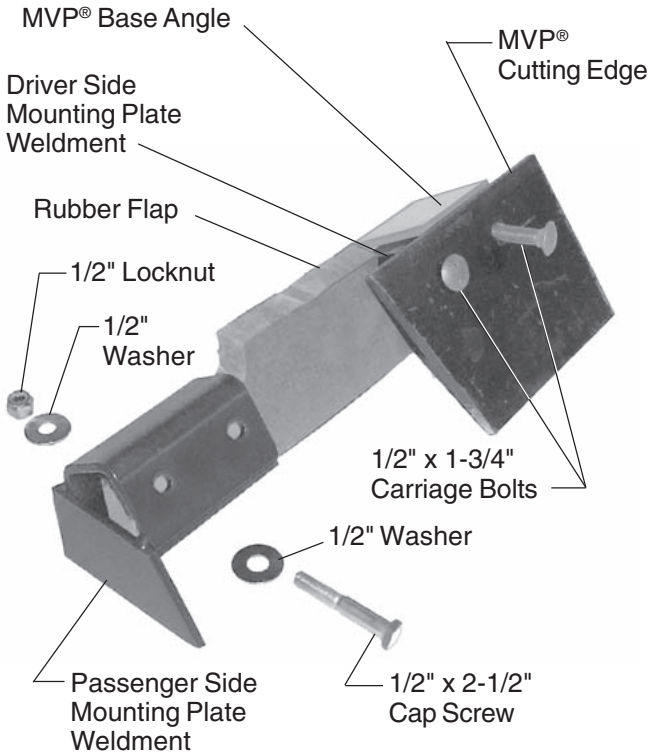
**NOTE: The top of the chain will be attached to the lift channel at a later time.**

# INSTALLATION INSTRUCTIONS

## RUBBER FLAP

**NOTE: The rubber flap can not be installed unless the plow is attached to vehicle and in the raised position OR raised in a different manner to provide access to both front and rear of the cutting edge.**

1. Using four 1/2" x 1-3/4" carriage bolts and 1/2" locknuts, install one mounting plate weldment to the back of each cutting edge. (See Figure 3.)



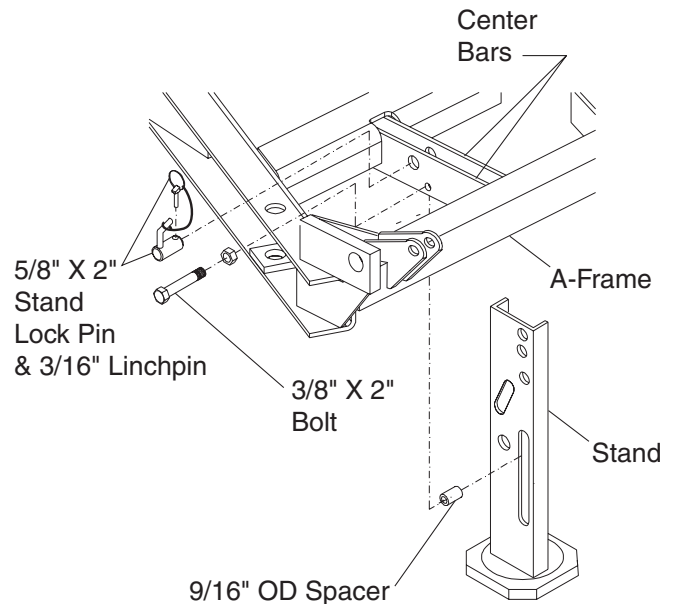
**Figure 3**

2. Adjust wings so that they are in line with each other or slightly forward in the scoop position.
3. Place 1/2" washer on 1/2" x 2-1/2" cap screw and insert cap screw into a hole in the rubber flap. The rubber flap is mounted with the longest edge facing the ground.  
Place rubber flap against rear inside surface of the mounting plate weldments and align holes in flap and weldments.  
Insert the cap screw through the hole in the back plate of the mounting bracket. Add 1/2" washer and 1/2" locknut. Tighten locknut until washer slightly deforms the rubber flap surface.
4. Insert the second 1/2" cap screw through the rubber flap and mounting plate weldment using the same washer and locknut assembly as mentioned above.

## STAND

(Refer to Figure 4 for steps 1-6.)

1. Position the stand next to the center bars of the A-frame with the long slot towards the rear or back of the A-frame.
2. Insert the 9/16" outside diameter spacer into the top end of the long slot in the stand.
3. Holding the spacer in place with a finger, insert the stand between the A-frame center bars and align the spacer with the small hole in the center bars.
4. Secure the spacer with a 3/8" x 2" bolt and locknut.
5. Hold the stand perpendicular to the A-frame. Align the short slot in the stand with the large hole in the center bars, and insert the 5/8" x 2" stand lock pin. Secure with a 3/16" linchpin.
6. Tip the snowplow assembly into the plowing position.

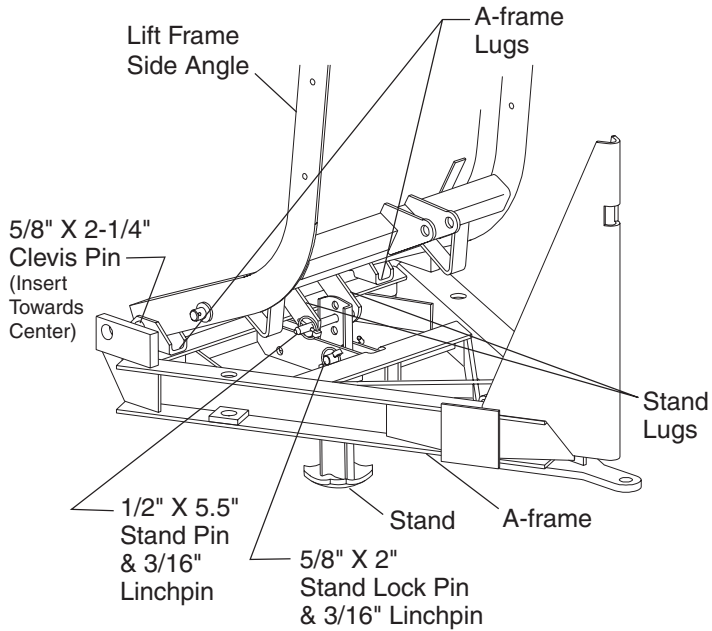


**Figure 4**

# INSTALLATION INSTRUCTIONS

## LIFT FRAME

1. Lay the lift frame on the floor with the curve facing upwards and the ends of the side angles positioned next to the rear (wide end) of the A-frame.



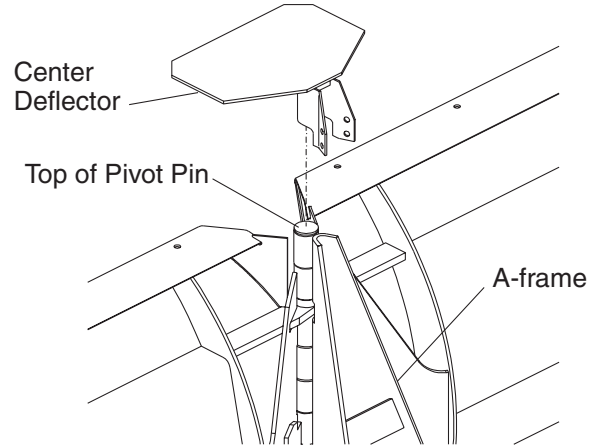
**Figure 5**

(Refer to Figure 5 for steps 2-4.)

2. Raise the end of the lift frame and align the holes in the side angles between the inner pairs of lugs on the wide end of the A-frame.
3. Secure the lift frame to the A-frame lugs with two 5/8" x 2-1/4" clevis pins inserted from the outside towards the center of the A-frame. Secure with cotter pins.
4. Rotate the lift frame to align the holes in the stand lugs to the bottom hole of the three hole pattern in the top of the stand. Secure with a 1/2" x 5.5" stand pin and a 3/16" linchpin.

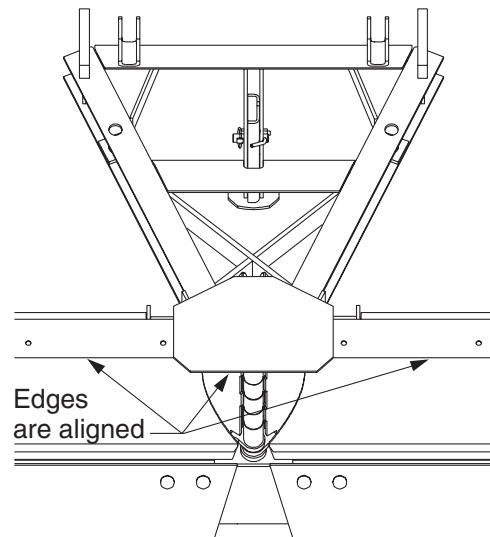
## CENTER DEFLECTOR

1. Lower the center deflector onto the A-frame until it touches the top of the pivot pin. (See Figure 6.)



**Figure 6**

2. Push the center deflector towards the back of the A-frame until the inside of the formed section touches the top hinge of the A-frame.
3. With the wings straight and the A-frame perpendicular to the blade, align the front edge of the center deflector with the top curl of the blade. (See Figure 7.)



**Figure 7**



# INSTALLATION INSTRUCTIONS

## CENTER DEFLECTOR (Continued)

- Using the four holes on the center deflector, centerpunch holes in the A-frame. (See Figure 8.)

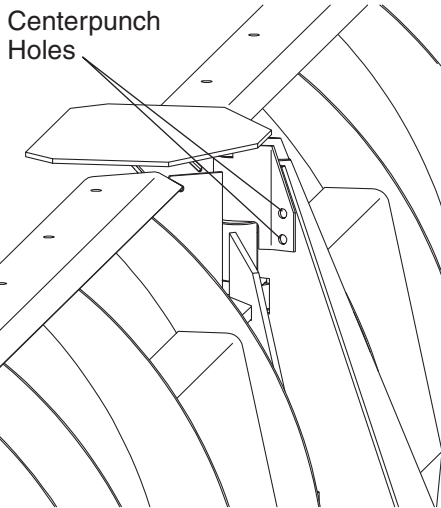


Figure 8

- Remove the center deflector and drill four 3/8" holes in the centerpunched locations.

---

**NOTE: Do not attach center deflector at this time.**

---

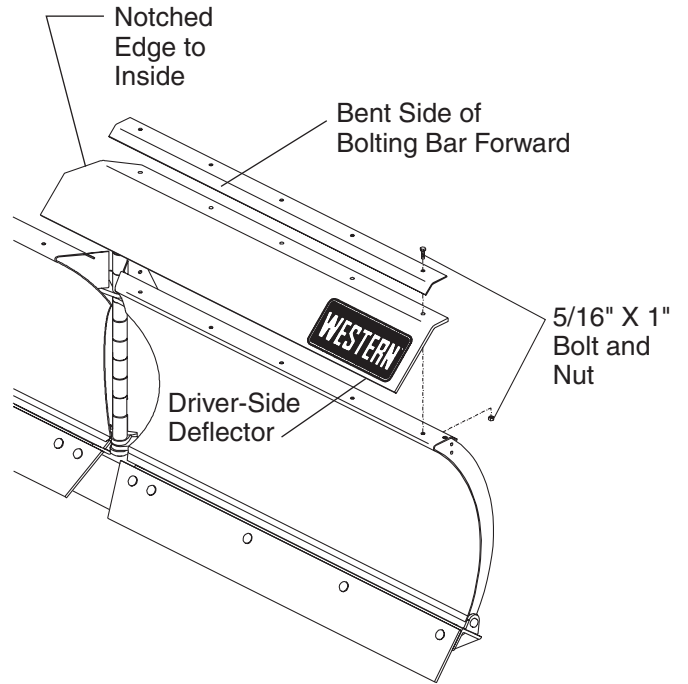


Figure 9

- Insert a 5/16" x 1" bolt into each hole and attach a nut to each bolt. (See Figure 9.)
- Install the center deflector using holes drilled in Step 5 of Center Deflector installation instructions, four 5/16" x 1" bolts, eight 5/16" flat washers, and locknuts.

When installed, bolt heads should be on the inside of the A-frame and nuts should be visible on the outside of the A-frame. (See Figure 10.)

## RUBBER DEFLECTOR

- Align the holes in the bolting bar, rubber deflector, and the top curl of the blade. The notched edge of the rubber deflector goes towards the inside. The rubber deflector with the WESTERN® logo goes on the driver side. The bent side of the bolting bar goes towards the front. (See Figure 9.)

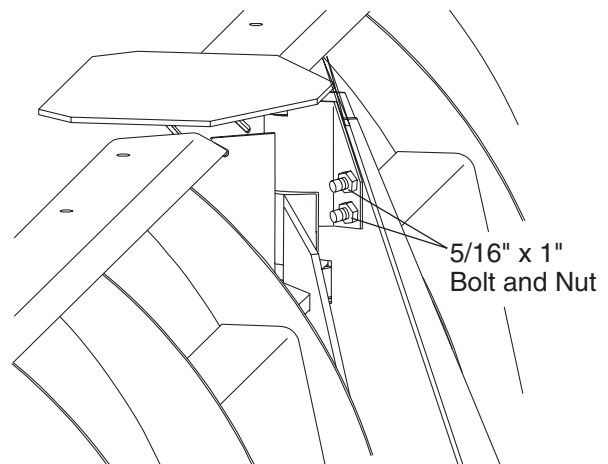


Figure 10

# INSTALLATION INSTRUCTIONS

## BLADE GUIDE ASSEMBLY

1. Insert the pointed end of the clamp into the coil of the blade guide rod.
2. Attach a blade guide rod to each outer rib using 5/16" x 1" cap screws and locknuts. (See Figure 11.)

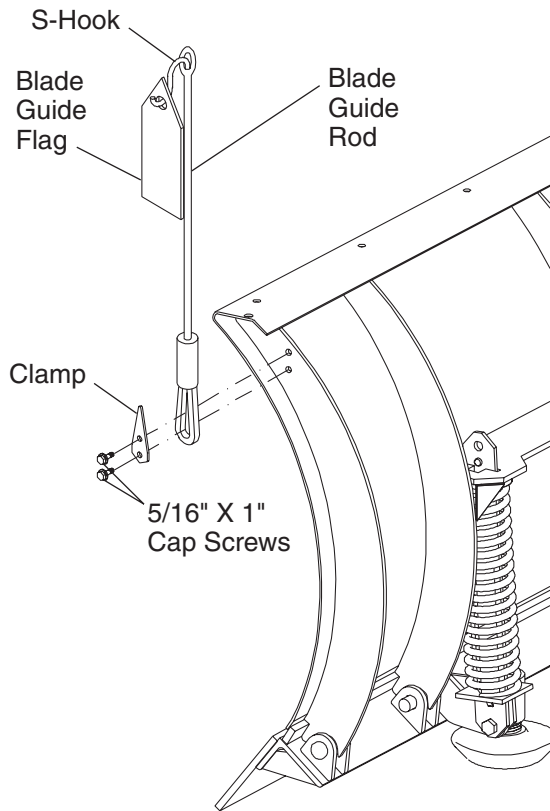


Figure 11

## LIFT CHANNEL, HYDRAULIC UNIT, HYDRAULIC FITTINGS & HOSES ASSEMBLY

1. Place the hole end of the lift channel between the lugs of the upper U-bracket on the lift frame. Insert a 3/4" x 3-3/4" bolt and secure with a 1/2" long spacer and nylon jam locknut. (Refer to Figure 15.)

**CAUTION**  
DO NOT OVERTIGHTEN. The lift channel must pivot freely.

Hoses and fittings are in the hydraulics box.

**CAUTION**  
Do not use thread sealant/tape when connecting hoses to swivel fittings. This could damage product or property.

2. Remove the five 1/4" pipe plugs from the bottom face of the valve on the hydraulic unit.
3. Install four 45° swivel fittings into angle ram ports. Position fittings as shown in Figure 12.

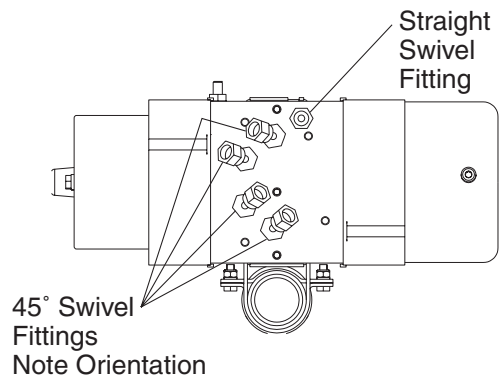


Figure 12

4. Install one straight swivel fitting into the lift port. (See Figure 12.)

(Continued on next page.)

# INSTALLATION INSTRUCTIONS

## LIFT CHANNEL, HYDRAULIC UNIT, HYDRAULIC FITTINGS & HOSES ASSEMBLY (Continued)

- Position the cylinder mount brackets (found in hydraulics box) around the lift ram with the shorter legs of the mounting bracket (stamped "TOP") towards the top (rod end) of the lift ram.

The hole in the back bracket fits over the stud on the lift ram. Secure as shown in Figure 12 with six 1/4"-20 x 3/4" bolts, 1/4" flat washers, and nylon locknuts. Torque to 9 ft./lb. (See Figure 13.)

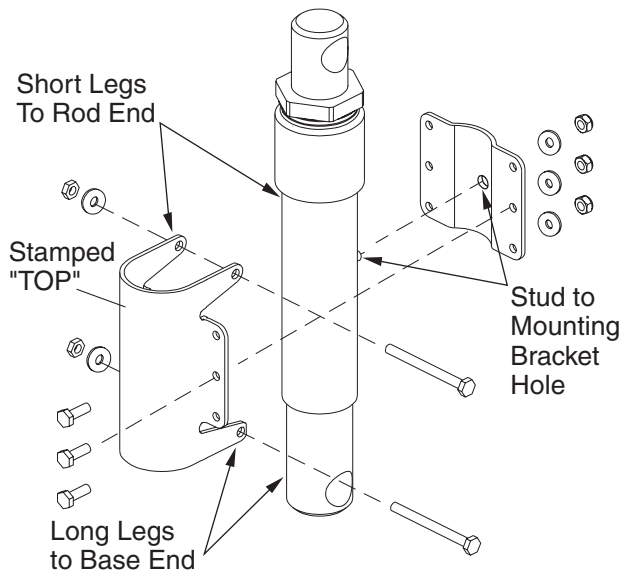


Figure 13

- Attach the shorter legs of the bracket to the top of the hydraulic valve block. Secure with a 1/4"-20 x 2-3/4" bolt, 1/4" flat washer, and nylon locknut.
- Attach the longer legs of the bracket to the bottom of the hydraulic valve block. Secure with a 1/4"-20 x 2-3/4" bolt, 1/4" flat washer, and nylon locknut.
- Attach 90° street elbow to the 18" hydraulic hose. Attach hose to base end of lift ram. Attach other end with 90° fitting to straight swivel fitting. **Verify there is no twist in the hose.** Twisting could damage the hose. (See Figure 14.)

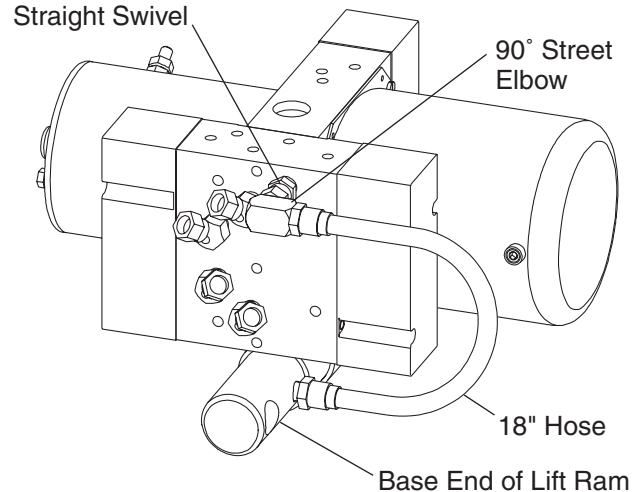


Figure 14

- Position the hydraulic unit with the nameplate facing the blade. Place the base end of the lift ram into the hole of the bracket on the lift frame and secure with a 3/4" x 3-3/4" cap screw, 11/16" long spacer, and nylon jam locknut. (See Figure 15.)

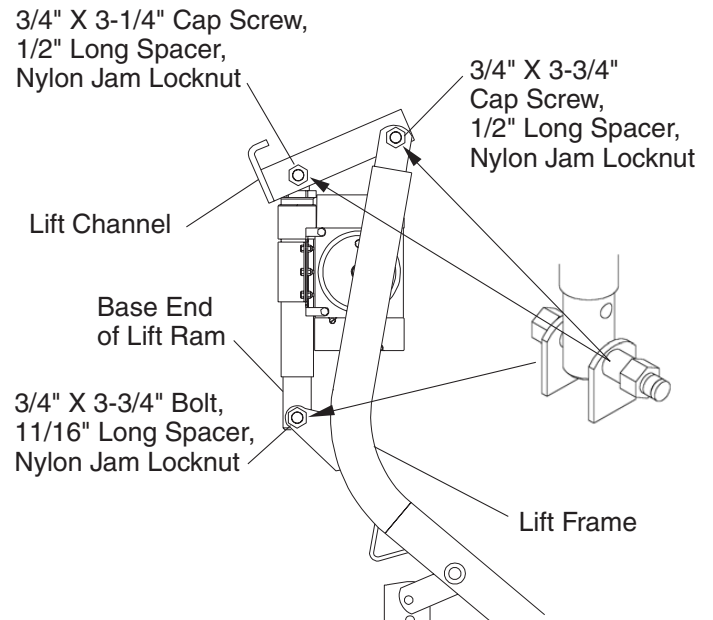


Figure 15

- Align the hole in the hydraulic unit lift ram with the hole near the hook on the lift channel and attach with a 3/4" x 3-1/4" cap screw, 1/2" long spacer, and a nylon jam locknut.

(Continued on next page.)

# INSTALLATION INSTRUCTIONS

## LIFT CHANNEL, HYDRAULIC UNIT, HYDRAULIC FITTINGS & HOSES ASSEMBLY (Continued)

11. Remove 3/8" square-headed plug from reservoir and install reservoir filler plug.
12. Install a 90° street elbow fitting into each port in the angling rams. Position fittings as shown in Figure 16.
13. Attach a 38" hose to the fitting on the rod end of each ram. (See Figure 16.)
14. Route rod end hoses through lift frame stops to avoid pinched hoses. (See Figures 16 and 17.)

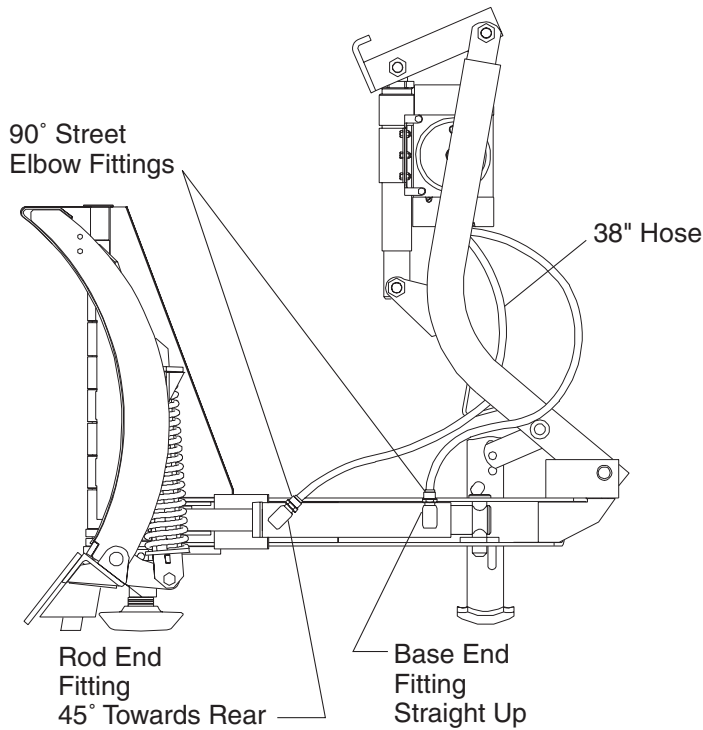


Figure 16

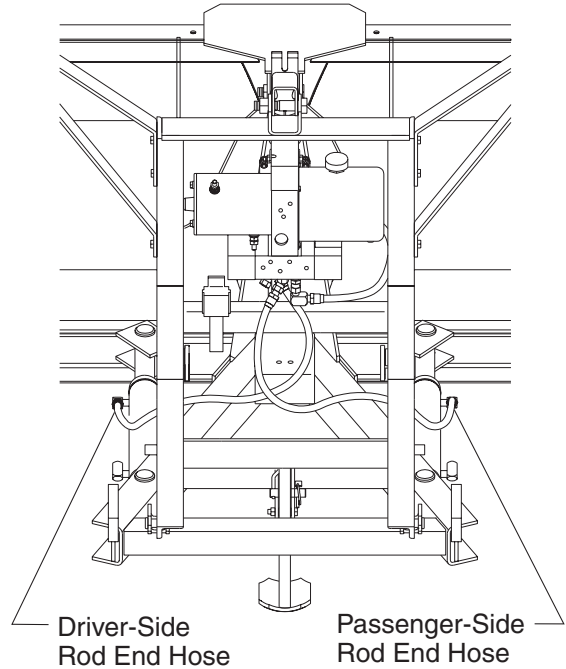


Figure 17

15. Attach the 38" hoses to the 45° swivel fittings on the hydraulic unit. (See Figure 18.)

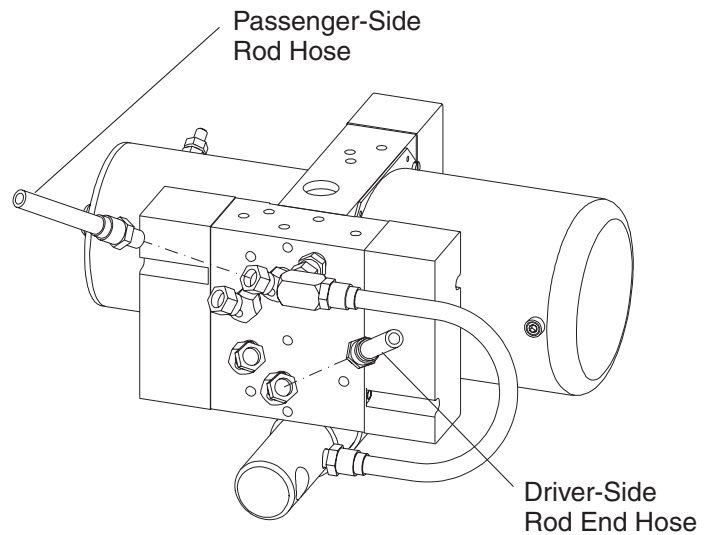


Figure 18

(Continued on next page.)

# INSTALLATION INSTRUCTIONS

## LIFT CHANNEL, HYDRAULIC UNIT, HYDRAULIC FITTINGS & HOSES ASSEMBLY (Continued)

16. Attach a 36" hose to the fitting on the base end of each ram. (See Figure 19.)
17. Route base end hoses behind lift frame angles. (See Figures 19 and 20.)

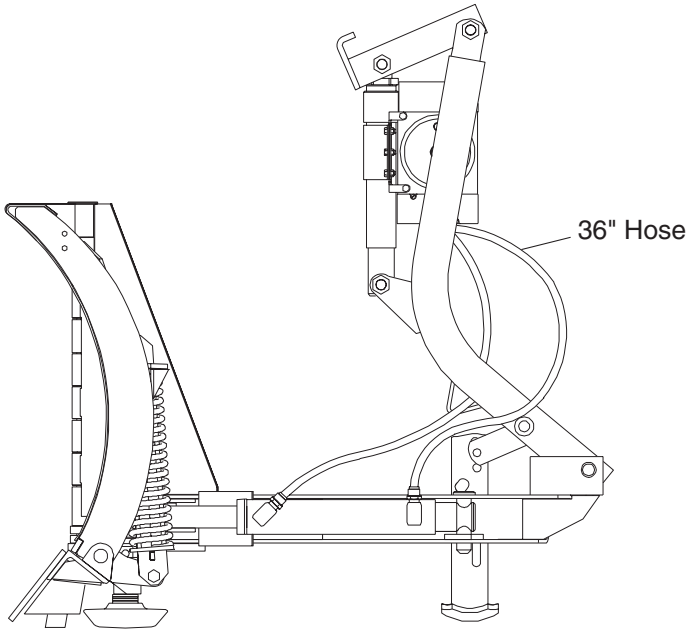


Figure 19

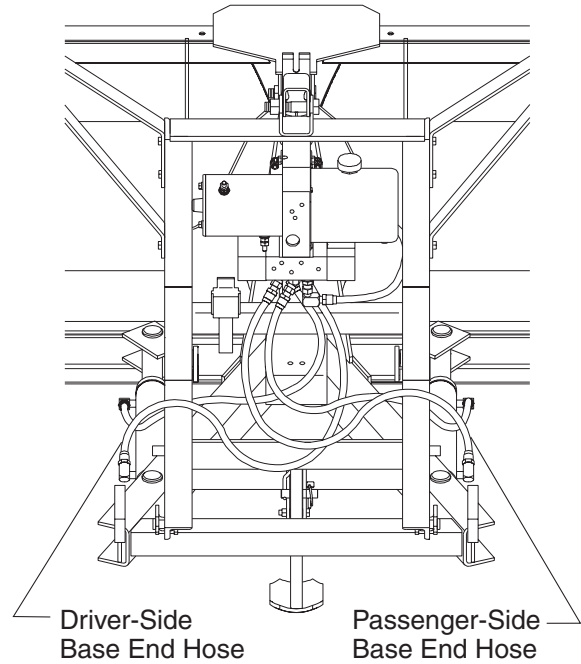


Figure 20

18. Attach to 45° swivel fittings on the hydraulic unit. (See Figure 21.)

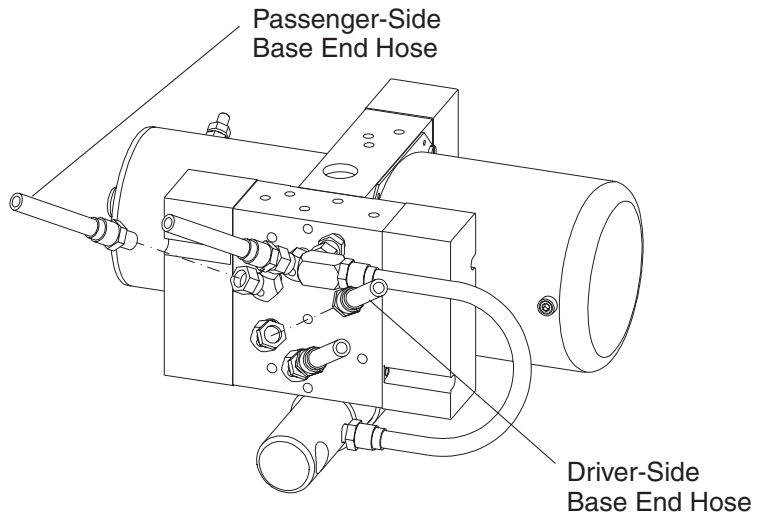


Figure 21

**NOTE:** After plow is attached to vehicle, adjust position of hydraulic fittings, if necessary, to eliminate any interference between hydraulic hoses and front of vehicle. Hoses must have smooth contours with no sharp bends.

# INSTALLATION INSTRUCTIONS

## LIGHT BRACKETS/HEADLAMPS ASSEMBLY

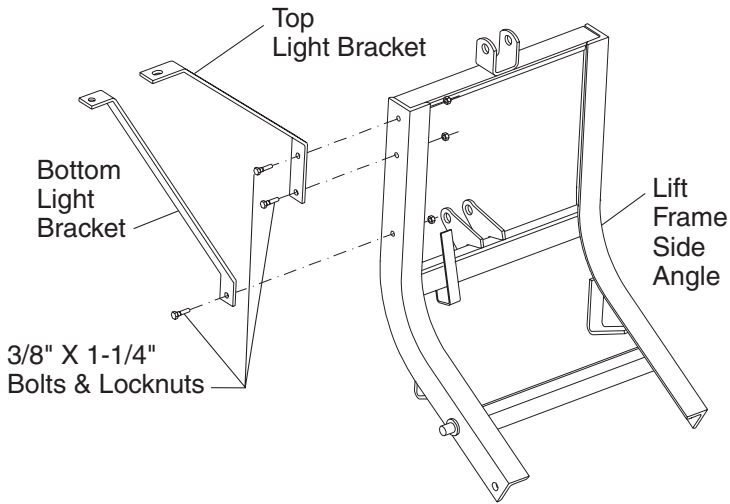


Figure 22

Refer to Figure 22 for the following instructions.

1. Align the two holes of the two top light brackets with the top two holes in the lift frame side angles. Loosely attach with two 3/8" x 1-1/4" bolts and locknuts on each side.
2. Loosely attach the small hole end of each bottom light bracket to the lowest hole in each lift frame side angle with a 3/8" x 1-1/4" bolt and locknut on each side.
3. Assemble the headlamps with park/turn lens towards outside (found in the headlamp kit) to the light brackets placing the headlamp swivel above the bracket.
4. Loosely attach with lock washers and nuts below the brackets.

**NOTE: Aim headlamps when the snowplow is attached to the vehicle and in the raised position.**

5. Tighten the bolts that hold the light brackets to the lift frame.
6. Install vinyl caps on the headlamp mounting studs.

## HYDRAULIC UNIT WIRING ASSEMBLY

Refer to Figure 23 on the top of the next page for the following instructions.

1. Route the wiring harness from the headlamps along the top light brackets and across the back of the lift frame to the driver side of the lift frame.
2. Use any excess harness to make a loop under each headlamp.
3. Secure the harness to each light bracket with two short cable ties and to the top angle of the lift frame with a long cable tie.
4. Remove the covers from the valve manifolds on the hydraulic unit.

**NOTE: Temporarily remove the bolt securing the lift cylinder rod to the lift channel and tilt the hydraulic unit forward for easier removal and installation of valve covers.**

5. Route the branch of harness with loose wires to the manifolds.

**NOTE: Dielectric grease has been applied to coil terminals. DO NOT wipe off terminals.**

6. Apply dielectric grease (P.N. 56099) (furnished in the hydraulics box) into the opening of each wire terminal before connecting to the coil terminals as shown on the label on the inside of each cover and in Figures 24, 25, and 26 on the next page.

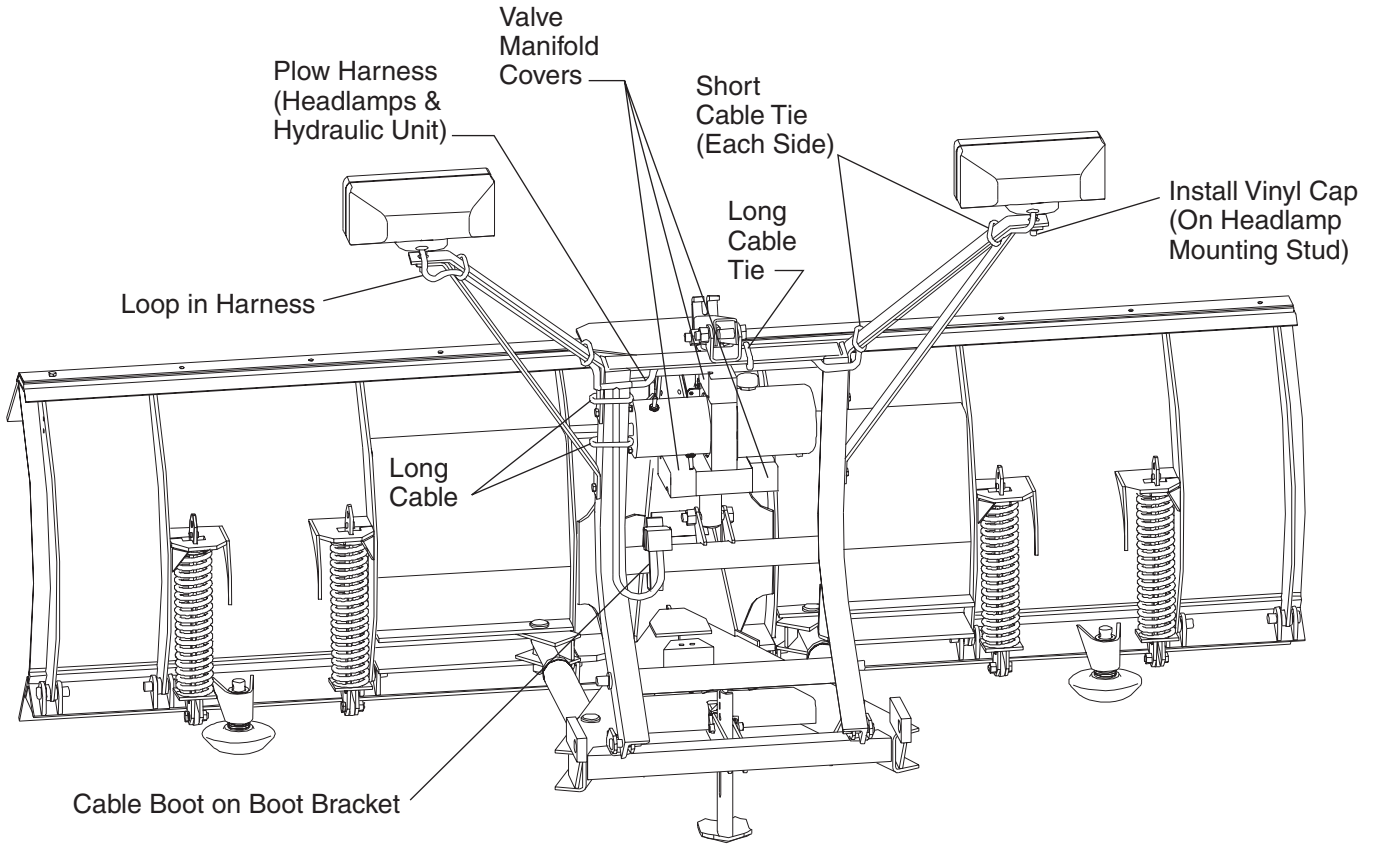
**NOTE: The strain reliefs must be inside the covers to prevent the connections from coming loose.**

7. With each harness strain relief inside the cover at the slot, replace each cover and secure with screws.
8. While allowing slack in the harness to the hydraulic unit, secure the harness to the inside of the lift frame side rail with two long cable ties.

(Continued on next page.)

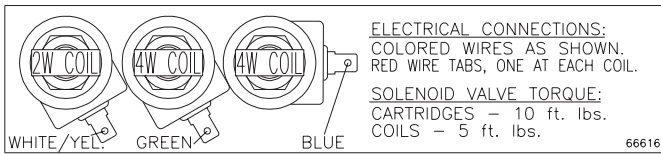
# INSTALLATION INSTRUCTIONS

## HYDRAULIC UNIT WIRING ASSEMBLY (Continued)

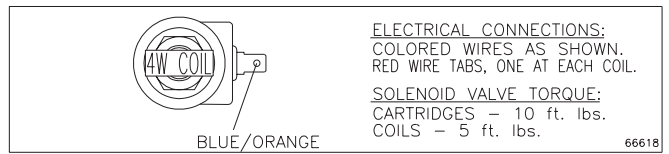


**Figure 23**

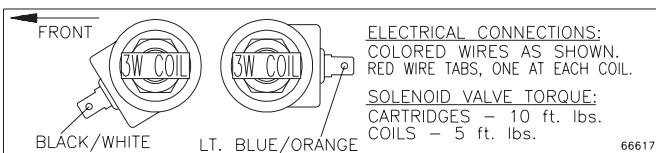
Wire the solenoids according to the diagrams below (these diagrams are also found inside the solenoid covers). (See Figures 24, 25, and 26.)



**Figure 24**



**Figure 26**



**Figure 25**

# INSTALLATION INSTRUCTIONS

## BATTERY CABLE ASSEMBLY

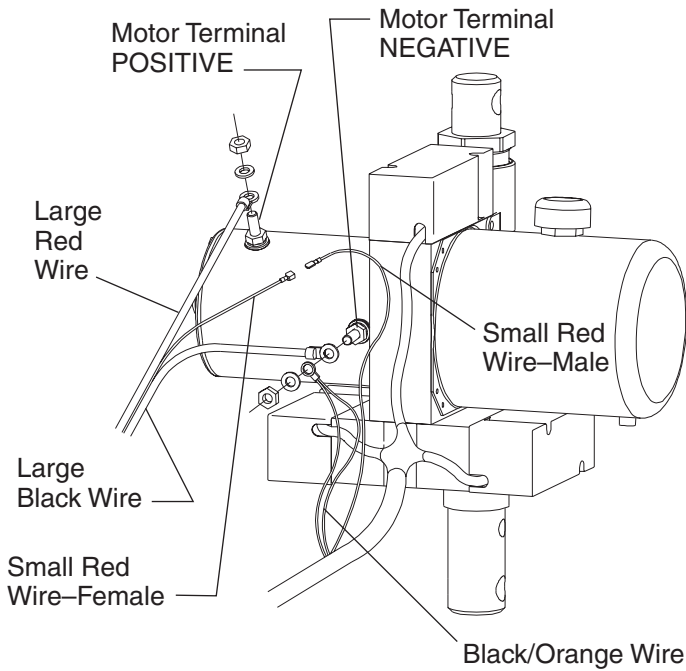


Figure 27

2. Attach the large black wire and the black/orange wire from the snowplow harness to the NEGATIVE (-) motor terminal on the hydraulic unit. Tighten nut to 50-60 in. lbs.
3. Attach the small red wires by connecting the male terminal to the female terminal.
4. Slide the small pocket of the cable boot onto the vertical tab of the boot bracket located on the lift frame. (See Figure 23 on previous page.) Insert the harness plugs into the boot for storage when the snowplow is removed from the vehicle.

---

**NOTE: Retain dielectric grease tube for use during vehicle mount installation. Give the tube to the end user.**

---

Refer to Figure 27 for the following instructions.

---

**NOTE: Apply a light coating of dielectric grease to connectors before assembly.**

---

All parts installed in this section are found in the hydraulics box.

1. Attach the large red wire to the positive (+) motor terminal on the hydraulic unit. Tighten nut to 50-60 in. lbs.

### **⚠ CAUTION**

**Twisting motor stud while tightening cable nut may damage the motor.**



# INSTALLATION INSTRUCTIONS

## VEHICLE HARNESS AND VEHICLE CABLE INSTALLATION

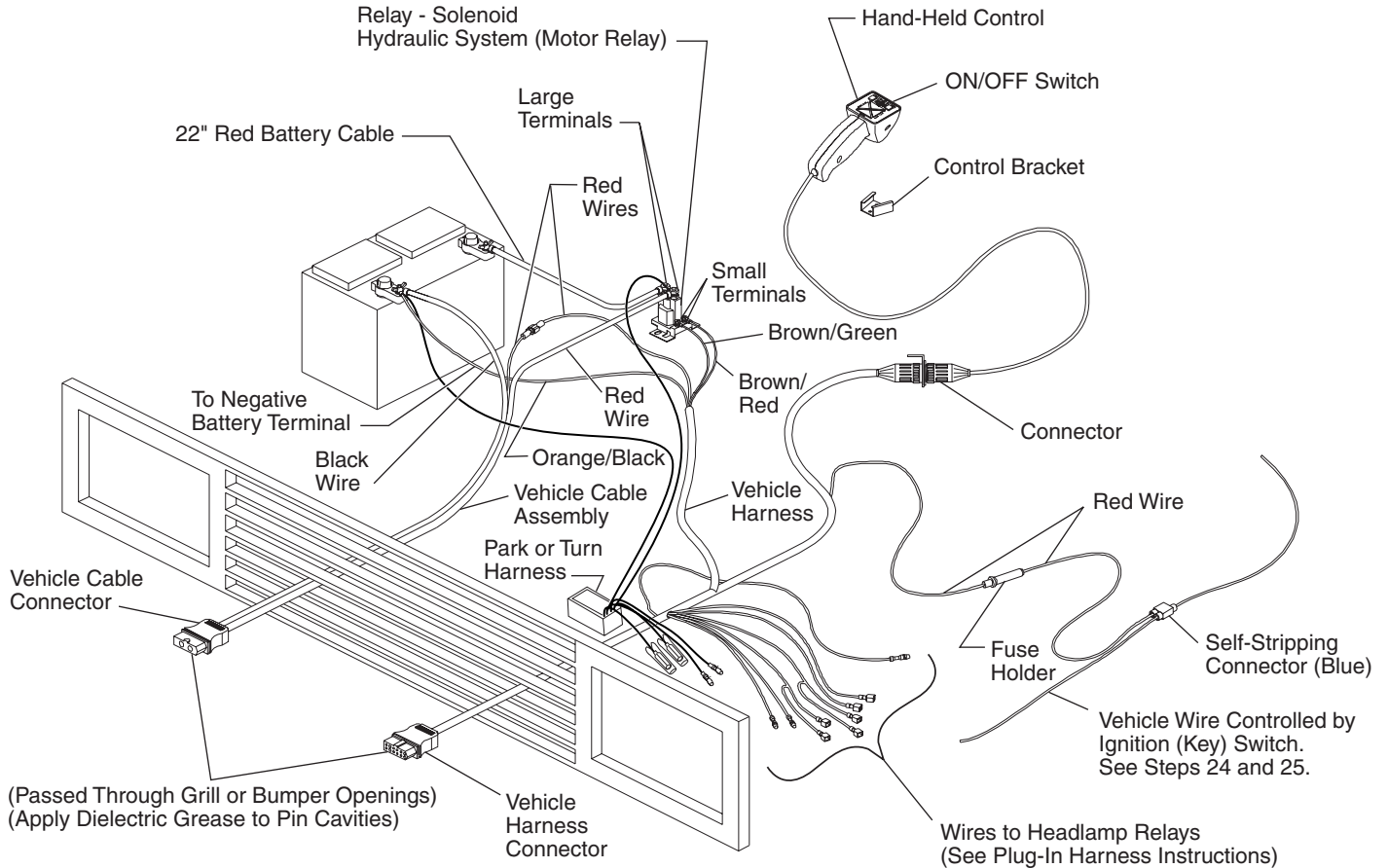


Figure 28

**NOTE: Use dielectric grease to prevent corrosion on all connections. Fill receptacles and lightly coat ring terminals and blades before assembly.**

**NOTE: This is a “low side” drive electrical system for the hydraulic unit. With a “low side” drive system, positive is provided continuously to the solenoid coils, and the ground is switched on and off to control the solenoids.**

1. Identify the wires for the parking lamp on the driver side and for the turn signals on both sides. Attach a black, self-stripping bullet receptacle connector (found in the headlamp kit) to each of these three wires.

2. Turn off the vehicle ignition and disconnect both the NEGATIVE (-) and POSITIVE (+) battery cables.
3. Find a location for the motor relay where it will be protected from road splash and will be within 18" of the vehicle primary battery.

**NOTE: Motor relay terminals must be vertical or horizontal.**

4. Using the motor relay mounting plate as a template, drill two 9/32" holes and mount the motor relay to holes using 1/4" X 3/4" bolts, washers, and locknuts.

(Continued on next page.)

# INSTALLATION INSTRUCTIONS

## VEHICLE HARNESS AND VEHICLE CABLE INSTALLATION (Continued)

5. Route the 22" red battery cable between a large motor relay terminal and the POSITIVE battery terminal avoiding sharp edges and hot or moving parts.

**See vehicle harness and vehicle cable installation in mount box instruction for special battery connection information.**

Park or turn harness kits (see Harness Kit selection in mount box instructions for applications):

- Locate insulated end of park or turn harness behind driver side headlamp.
- Route red and black wires with ring terminals to the battery.
- Route black wire to battery ground terminal.  
**DO NOT attach ground at this time.**
- Attach red wire with fuse holder to either battery positive terminal or to motor relay terminal with 22" red cable attached.

Secure 22" red cable on top of any other ring terminals to motor relay terminal with lock washer and 5/16"-24 jam nut.

Secure positive battery terminal using special instructions from mount box or original fasteners.

6. Stretch the rectangular openings of the plug cover straps (found in the harness kit) over the connector ends of the vehicle cable assembly (found in the hydraulics box) and the 12-pin vehicle harness (found in the light kit). Place the plug covers over the molds on the harnesses.
7. Find a location in the vehicle grill or bumper opening on the battery side for routing the vehicle cable connector.
- The best location is at least 10-1/2" from the center of the grill and at a convenient height for connecting the snowplow plugs. Allow the connectors of the harness and cable to hang out in front of the grill or bumper opening. Allow enough slack so it is easy to connect and disconnect the connectors.
8. Route the vehicle cable through the grill or bumper opening at the selected location and through or around the radiator bulkhead to the motor relay avoiding sharp edges, and hot or moving parts.
9. Attach the large red wire from the vehicle cable to the unused large motor relay terminal with a lock washer and 5/16"-24 jam nut.

10. Route the black wire from the vehicle cable to the existing terminal fastener on the NEGATIVE battery terminal. **DO NOT attach wire at this time.**
11. Find a location in the vehicle grill or bumper opening on the driver side for routing the vehicle harness. See Figure 28 on the previous page for routing the vehicle harness.
12. Route the vehicle harness through grill or bumper opening and around, or through radiator bulkhead.
13. Route the wires that break out of the vehicle harness to the area behind the driver-side headlamp. Route the rest of harness to the firewall.

### CAUTION

**Before drilling any holes, check both sides of the material for any wires, fuel lines, fuel tanks, etc., that may be damaged by drilling.**

14. Drill a 5/8" hole through the firewall of the truck in a convenient location away from sharp edges and hot or moving parts.
15. Route the harness breakout with the orange w/black stripe, brown w/red stripe, brown w/green stripe, and red wires to the motor relay.
16. Install the brown w/red stripe and brown w/green stripe wires to the small terminals of the motor relay. Secure with #10 lock washers and 10-32 nuts.
17. Connect the black wire of the vehicle cable, the vehicle harness orange w/black stripe ring terminal and any park or turn harness black wire ring terminal(s) to the NEGATIVE battery terminal.
18. All vehicles with DRL's - Insert fuse holder on pink wire of DRL Adapter Kit (P.N. 61584) through firewall first. Route end of pink wire with receptacles to area of driver-side headlamp.
19. Remove the packing material from the end of the harness near the fuse. This will expose 10 socket-type terminals. Push the fuse holder through the firewall hole and then carefully feed the end of the harness with the 10 terminals through to the cab.

(Continued on next page.)

# INSTALLATION INSTRUCTIONS

## VEHICLE HARNESS AND VEHICLE CABLE INSTALLATION (Continued)

20. Locate a connector bracket mounting position under the dash where it will not interfere with other equipment. Mount the connector bracket using #8 x 5/8" tapping screws and washers.

### ⚠ CAUTION

Do not alter, modify, or install additional components in shaded areas of Figure 29. Failure to comply may cause damage to the product or property.

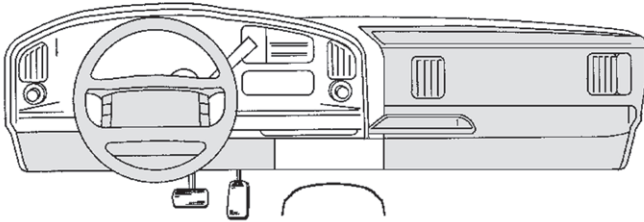


Figure 29

21. Feed the vehicle harness through the bracket.
22. Insert each of the 10 socket-type terminals into the connector housing. (See Figure 30.)  
Refer to the Table 1 for under-dash vehicle harness connector pin assignments.

**NOTE: A "snap" will be felt as the terminals are successfully inserted. An extraction tool is provided for removal of pin terminals if necessary.**

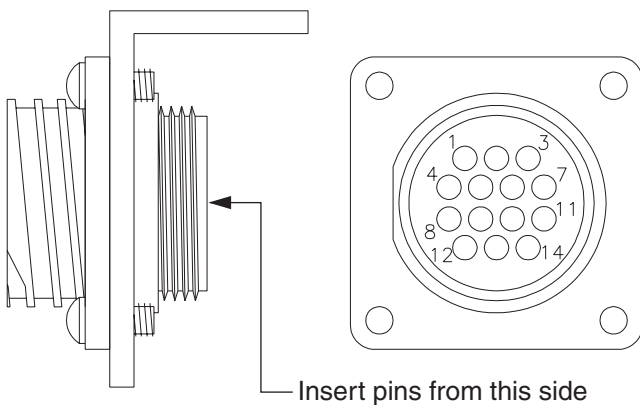


Figure 30

Wire Color	Pin No.
Light Blue With Orange Stripe	1
Blue With Orange Stripe	2
Black With White Stripe	3
Light Green	4
Light Blue	5
White With Yellow Stripe	6
Brown With Red Stripe	7
Red	8
Orange With Black Stripe	9
Brown With Green Stripe	10

Table 1

23. Secure the connector to the bracket with the provided #6-32 x 1/4" tapping screws and lock washers.
24. Locate an accessory wire that is controlled by the ignition switch (power is turned off when the ignition switch is in the OFF position). Review the Vehicle Harness and Motor Relay Installation section found in the Mount Instructions for any specific recommendations that may apply to your vehicles.
25. Route the 10-amp fuse holder red wire to this location and trim excess length (leave the 10-amp fuse holder in the system).
26. Open the blue, self-stripping connector and place the end of the red wire against the inner groove stop (end of wire must not extend from the connector when it is closed) and the accessory wire in the outer groove. Close the connector over the wires using a pliers and snap the locking tab into place.
27. Connect the female spade terminal on the small red wire from the vehicle cable to the male spade terminal on the red wire from the vehicle harness.
28. Insert a rubber grommet into the firewall hole. Secure harness as required with supplied cable ties.

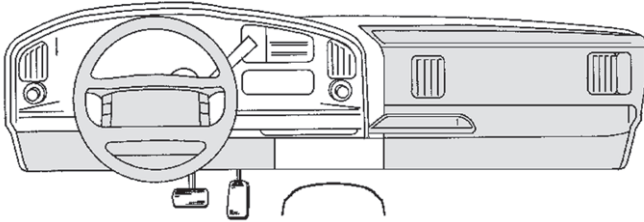
# INSTALLATION INSTRUCTIONS

## MOUNTING THE CABCOMMAND HAND-HELD CONTROL

1. Locate a convenient control mounting position in the cab that will not interfere with other equipment and will avoid unintentional activation of the snowplow.

### **⚠ CAUTION**

**Do not alter, modify, or install additional components in shaded areas of Figure 31. Failure to comply may cause damage to the product or property.**



*Figure 31*

### **⚠ CAUTION**

**Before drilling any holes, check both sides of the material for any wires, fuel lines, fuel tanks, etc., that may be damaged by drilling.**

2. Using the control bracket as a template, mark and drill three holes.
3. Secure the control bracket to the truck inserting a #6 x 1" tapping screw and a #6 spring lock washer into each hole.

## HEADLAMP HARNESS INSTALLATION

Specific instructions for the installation of the Plug-In Harness to the vehicle headlights and the headlamp switching relays will be found either in:

**special instructions contained in the harness kit specified in the Selection List**

**or**

**in the installation instructions found in the mount box.**

# OPERATIONAL TEST AND ADJUSTMENTS

## FILLING THE HYDRAULIC UNIT

**NOTE: Mount the plow assembly to the vehicle. (See label on back of blade or Owner's Manual for mounting instructions.)**

Verify proper hydraulic hose routing see page 8 and 9.

**NOTE: Add oil when all cylinders are retracted.**

1. Fill the reservoir to the dipstick level while in the Vee position with the snowplow lowered (lift ram retracted all the way).

### SYSTEM CAPACITY

- Reservoir—1-3/4 quart
- Complete System—2-1/2 quarts

### USE

- WESTERN® High Performance Fluid to -25° F (-32° C)  
Part No. 49311 - Quart  
Part No. 49330 - Gallon
- Automatic Transmission Fluid (ATF) DEXRON® III to -10° F (-23° C)
- Texaco 1537 Aircraft Hydraulic Oil for temperatures below -25° F (-32° C)

2. Turn ignition (key) switch to the ON or ACCESSORY position. Press the control power button. The control indicator light will turn on.
3. Turn the control ON/OFF switch to the ON position.
4. Hold the MODE button down for 2 seconds (the mode light will flash) to put the snowplow in single wing mode. The right and left buttons now work as toggles. For example, pressing the button once will retract the blade wing. Pressing the button again will extend the blade wing.
5. Extend and retract the driver-side wing several times. Return all rams to the retracted position. Refill reservoir.
6. Screw dipstick in completely to read fill level. Fill with fluid according to dipstick reading.
7. Extend and retract the passenger-side wing several times. Return all rams to the retracted position. Refill reservoir.
8. Screw dipstick in completely to read fill level. Fill with fluid according to dipstick reading.
9. Raise and lower the snowplow several times. Return to the lower position retracting the cylinders completely.
10. With angling cylinders and the lift cylinder retracted, refill the system through the fill hole. Use the dipstick to indicate the level. Fill to full.

# OPERATIONAL TEST AND ADJUSTMENTS

## BLADE DROP SPEED ADJUSTMENT

The quill on the bottom rear of the main block valve adjusts blade drop speed. (See Figure 34.)

- Turn the quill IN (clockwise) to decrease drop speed.
- Turn the quill OUT (counterclockwise) to increase drop speed.

**NOTE: Turning the quill in too far can slow raise time.**

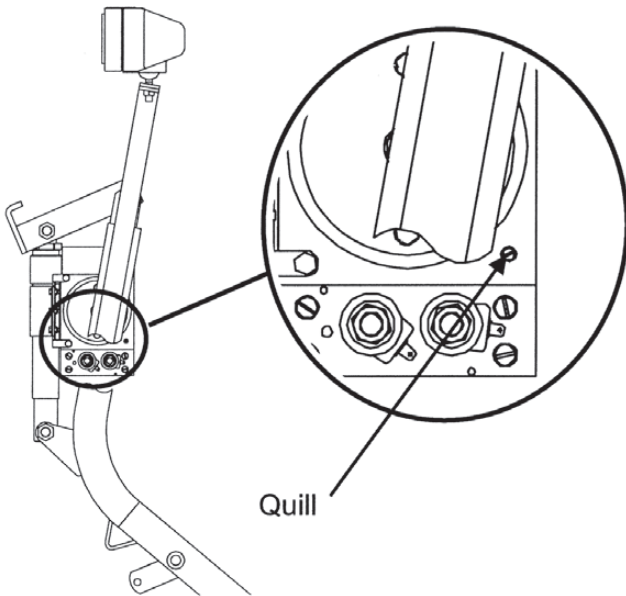


Figure 34

## FINAL INSPECTION

1. Make sure all fasteners and hydraulic and electrical connections are tight.
2. Check ram packing nuts for oil leakage. If excessive leakage is observed, tighten the packing nut 1/4 turn after you feel the nut contact the packing.

**NOTE: Do not over tighten packing nuts. Over tightening affects cylinder operation and shortens the life of the packing. A short period of normal operation will allow chevron packings to become saturated, and leakage will normally stop. A small amount of leakage is necessary to properly lubricate the cylinder rod.**

## COUPLING LUG HEIGHT CHECK

1. Mount plow to vehicle. (See label on back of blade or Owner's Manual for mounting instructions.) Add recommended ballast as found in Selection List.
2. Lift Plow and move vehicle a minimum of 10 feet.
3. With the blade on a level surface:
  - slack in lift chain
  - rear ballast located behind rear wheels
  - the center of the coupling holes (hitch pin shaft) to level surface should measure 9-1/2" to 10-1/2".

To obtain height, both Coupling Lugs and Link Arms may be turned over to change height 1".

(See Figure 35.)

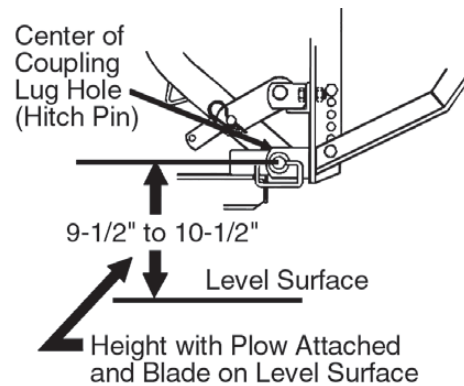


Figure 35

**NOTE: Coupling height must be 9-1/2" minimum to allow stand to be pinned to frame.**

4. Adjust chain slack with plow mounted to vehicle and lift channel pushed all the way down. To adjust, remove chain from hook, straighten chain and pull tight. Rehook it to the lift channel. After chain is hooked, it will have the correct amount of slack for blade "float". DO NOT remove chain from lift channel when removing plow from vehicle.

# OPERATIONAL TEST AND ADJUSTMENTS

---

## VEHICLE LIGHTING CHECK

1. Check the operation of vehicle and plow lights with plow mounted to vehicle and all harnesses connected.

### Turn signals and parking lamps

#### Parking lamps ON

- Both vehicle and plow parking lamps should be on at the same time.

#### Right turn signal ON

- Both vehicle and plow right turn signal lamps should flash at the same time.

#### Left turn signal ON

- Both vehicle and plow left turn signal lamps should flash at the same time.

### Headlamps

Move vehicle headlamp switch to the ON position. Connecting and disconnecting the 12-pin plow plug from the vehicle harness connector should switch between vehicle and plow headlamps as follows:

#### 12-pin plow plug DISCONNECTED

- Vehicle headlamps should be on.
- Plow headlamps should be off.

#### 12-pin plow plug CONNECTED

- Plow headlamps should be on.
- Vehicle headlamps should be off.

Dimmer switch should dim whichever headlamps are operating. The high beam indicator on the dash should light when either set of headlamps is on high beam.

2. Connect plow plug to vehicle harness connector. Raise plow and aim plow headlamps according to SAE J599 Lighting Inspection Code (**see Service Bulletin SP 608**) and any state or local regulations.
3. Check aim of vehicle headlamps with plow removed.
4. When plow is removed from the vehicle, install plug covers on vehicle harness connectors and insert the plow plugs into the boot on the hydraulic unit.

**After using the snowplow for 5-10 hours, retorque all mount assembly fasteners.**



WESTERN PRODUCTS  
P.O. BOX 245038  
MILWAUKEE, WI 53224-9538

 A DIVISION OF DOUGLAS DYNAMICS, L.L.C.

Western Products reserves the right under its Product Improvement Policy to change construction or design details and furnish equipment when so altered without reference to illustrations or specifications used herein. Western Products and the vehicle manufacturer may require and/or recommend optional equipment for snow removal. This product is manufactured under the following patents: 4,280,062; 5,420,480; and Re 35,700 with additional patents pending. Western Products offers a limited warranty on the snowplows and accessories. See separately printed page for this important information. The following are registered® trademarks of Douglas Dynamics, L.L.C.: MVP®, UNIMOUNT®, and WESTERN®.