



**CHEVY/GMC 1500/2500/3500 4x4
1999 & LATER
VEHICLE SPECIFIC ELECTRICAL
INSTALLATION INSTRUCTIONS
Model No. 3519 and Model No. 3529**

Straight Blade (Models 3519 & 3529)

Hydraulic Box No. 56588

2003 & Later: Harness Kit No. 64077 (HB-3 & HB-4 QUAD Lights)
Headlamp Kit 12-Pin (White) No. 64078

1999-2002: Harness Kit No. 63392 (HB-3 & HB-4 QUAD Lights)
Headlamp Kit 9-Pin No. 61540-1

MVP® Blade (Model 3529)

Hydraulic Box No. 56777

2003 & Later: Harness Kit No. 64085 (HB-3 & HB-4 QUAD Lights)
Headlamp Kit 12-Pin (White) No. 64078

1999-2002: Plug-In Harness 63394 (HB-3 & HB-4 QUAD Lights)
Headlamp Kit 66640-1 MVP 12-Pin

⚠ CAUTION

Read this document before installing the snowplow.

⚠ CAUTION

See your WESTERN® outlet for application recommendations. The Selection List has specific vehicle and snowplow requirements.

TABLE OF CONTENTS

SAFETY	1	MVP IN-CAB CONTROL WIRING	11
Safety Definitions	1	2003 and Later Installations with DRLs	11
Battery Safety	1	Vehicle Harness and Vehicle Cable	
Torque Chart	1	Installation	13
UNDER HOOD INSTALLATION	2	WIRING DIAGRAMS - MVP BLADE	15
Harness Kit Selection	2	Electrical Schematic – 2003 and Later MVP	
Vehicle Harness and Motor Relay	3	Blade Hydraulics	15
Plug-in Harness and Headlamp Relay		Electrical Schematic – 1999 to 2002 MVP	
Installation	6	Blade without DRLs	16
WIRING DIAGRAM - STRAIGHT BLADE / MVP®		12-PIN HEADLAMP KITS	17
BLADE	8	61550-1 and 64078 Headlamp Kits	17
2003 and Later Relay Connection Diagram			
12-Pin (White)	8		
1999 to 2002 Relay Connection Diagram	9		

SAFETY

SAFETY DEFINITIONS

WARNING

Indicates a potentially hazardous situation that, if not avoided, could result in death or serious personal injury.

CAUTION

Indicates a situation that, if not avoided, could result in damage to product or property.

NOTE: Identifies tips, helpful hints and maintenance information the owner/operator should know.

BATTERY SAFETY

CAUTION

Batteries normally produce explosive gases which can cause personal injury. Therefore, do not allow flames, sparks or lit tobacco to come near the battery. When charging or working near a battery, always cover your face and protect your eyes, and also provide ventilation.



Batteries contain sulfuric acid which burns skin, eyes and clothing.

Disconnect the battery before removing or replacing any electrical components.

TORQUE CHART

CAUTION

Read instructions before assembling. Fasteners should be finger tight until instructed to tighten according to the torque chart. Use standard methods and practices when attaching snowplow including wearing proper personal protective safety equipment.

Recommended Fastener Torque Chart (Ft.-Lb.)			
Size	 SAE Grade 2	 SAE Grade 5	 SAE Grade 8
1/4-20	6	9	13
5/16-18	11	18	28
3/8-16	19	31	46
3/8-24	24	46	68
7/16-14	30	50	75
1/2-13	45	75	115
9/16-12	66	110	165
5/8-11	93	150	225
3/4-10	150	250	370
7/8-9	150	378	591
1-8	220	583	893
Metric Grade 8.8 (Ft.-Lb.)			
Size	Torque	Size	Torque
M 6	7	M 12	60
M 8	17	M 14	95
M 10	35	M 16	155
These torque values apply to fasteners except those noted in the instruction.			

UNDER HOOD INSTALLATION

HARNESS KIT SELECTION

NOTE: Plow may be removed from vehicle for installation of electrical components.

NOTE: During electrical installation, the LONG BATTERY GROUND CABLE (no stripe) MUST BE GROUNDED TO THE NEGATIVE (-) BATTERY TERMINAL.

Straight Blade (Models 3519 & 3529)

For QUAD composite replaceable bulb type HB-3 and HB-4 headlamps use:

2003 and Later - Box No. 64078 Headlamp Kit 12-Pin (White) and 64077 Harness Kit HB-3 and HB-4 -H

1999 to 2002 - Box No. 61540-1 Headlamp Kit 9-Pin and 63392 Harness Kit HB-3 and HB-4 -F

MVP® Blade (Model 3529)

For QUAD composite replaceable bulb type HB-3 and HB-4 headlamps use:

2003 and Later - Box No. 64078 Headlamp Kit 12-Pin (White) and 64085 Harness Kit HB-3 and HB-4 -H

1999 to 2002 - Box No. 66640 Headlamp Kit MVP 12-Pin and 63394 Harness Kit HB-3 and HB-4 -F

Headlamp Kits 64078 and 61550-1 are assembled with the same housings and harnesses but have different internal wiring. See page 17 for wiring details of these two kits.

UNDER HOOD INSTALLATION

VEHICLE HARNESS AND MOTOR RELAY

NOTE: Except as noted, parts to be installed are found in hydraulics box.

NOTE: Use dielectric grease to prevent corrosion on all under hood electrical connections. Fill receptacles and lightly coat ring terminals and blades before assembly.

⚠ CAUTION

Batteries normally produce explosive gases which can cause personal injury. Therefore, do not allow flames, sparks or lit tobacco to come near the battery. When charging or working near a battery, always cover your face and protect your eyes, also provide ventilation.

Batteries contain sulfuric acid which burns skin, eyes and clothing.

Disconnect the battery before removing or replacing any electrical components.

(Continued on next page)

HARNESS, SOLENOID CONTROL & MOTOR RELAY INSTALLATION DIAGRAM

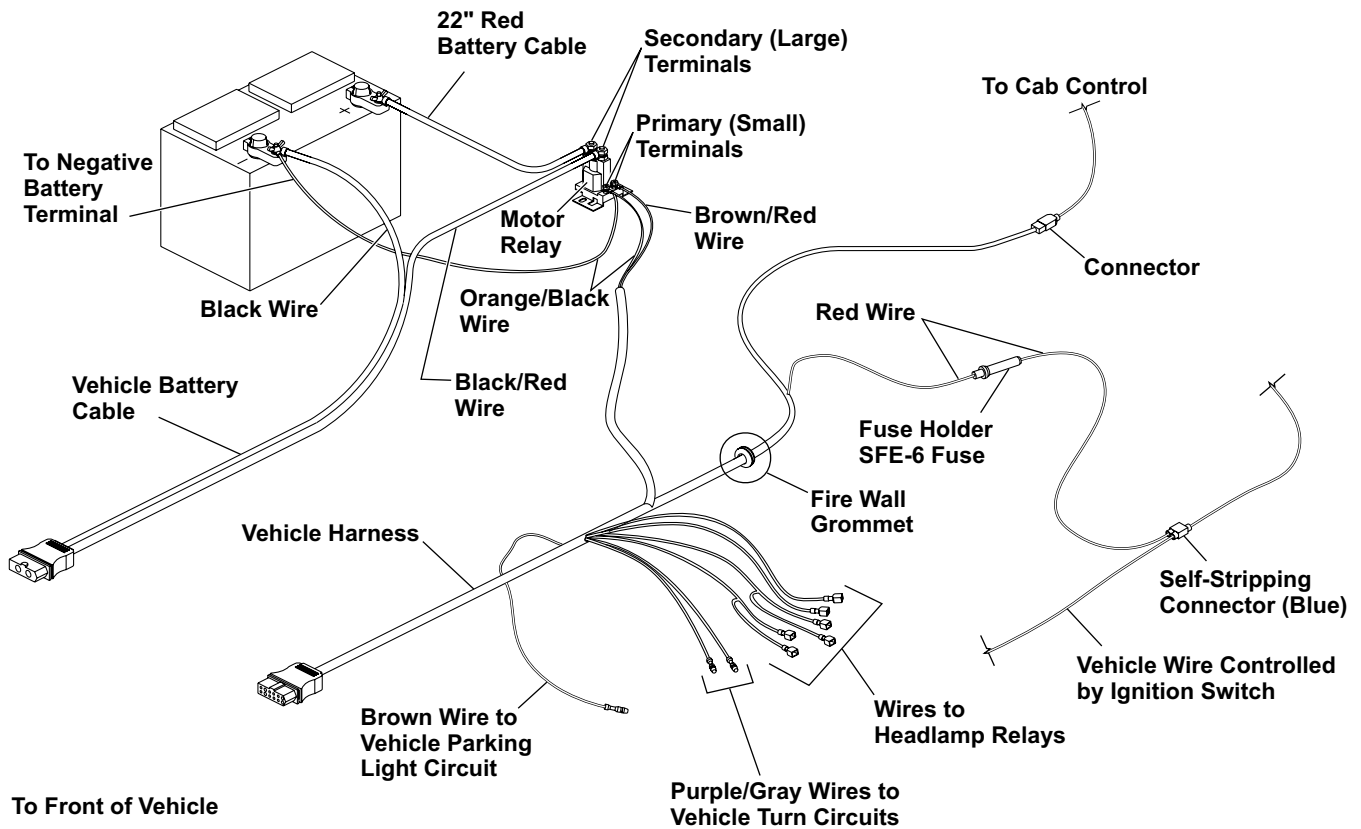

UNDER HOOD INSTALLATION

VEHICLE HARNESS AND MOTOR RELAY (Continued)

1. Identify wires for the parking lamp on the driver side and the turn signals on both sides of the vehicle. Attach a black self-stripping bullet receptacle connector (found in harness kit) to each of these three wires.
2. Remove NEGATIVE (-) battery cable from battery.
3. Find a location for the motor relay where it will be protected from road splash and within 18" of the vehicle primary battery.
7. Stretch rectangular openings of plug cover straps (found in harness kit) over harness connector ends of long battery cable assembly (found in hydraulics box) and vehicle harness (found in harness kit). Place plug covers over harness ends.

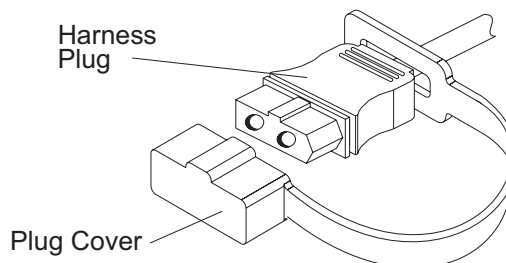

NOTE: Motor relay terminals must be up or horizontal.

4. Using the motor relay terminal as a template, drill two 9/32" holes, and mount motor relay to holes using 1/4" x 3/4" cap screws, flat washers and locknuts.
5. Route 22" battery cable between a large motor relay terminal and the POSITIVE (+) battery terminal taking care to avoid sharp edges and hot or moving parts. Place fuse holder eyelet on large relay terminal before 22" battery cable.
6. Attach cable and fuse holder wire to motor relay terminal with a lock washer and a 5/16"-24 jam nut. Attach other end of 22" battery cable to POSITIVE (+) battery terminal with furnished battery adapter. (Adapters found in mount box.) Position cable and tighten battery adapter to 124-178 in-lb. Attach OEM battery cable to adapter with original bolt. Position cable and hold adapter while tightening original battery bolt to 124-178 in-lb.
8. Find a location in the vehicle grille/bumper area on the battery side for mounting the battery cable connector. The best location is at least 10-1/2" from the center of the grille and at a convenient height for connecting the plow plugs.
9. Allow connector of each harness to hang out in front of grille or bumper opening. Allow enough cable so it is easy to mate and remove connector. Secure with long cable ties (found in mount box).
10. Route battery cable through the grille or bumper at the selected location and through or around the radiator bulkhead to motor relay taking care to avoid sharp edges, and hot or moving parts.
11. Attach cable with red stripe to the unused large terminal on the motor relay, and secure it with a lock washer and 5/16"-24 jam nut.

Fuse Holder Assembly



(Continued on next page)

UNDER HOOD INSTALLATION

VEHICLE HARNESS AND MOTOR RELAY (Continued)

12. Route cable without a stripe directly to the NEGATIVE (-) battery terminal (carefully separate the two cables as needed to reach the battery ground connection). DO NOT reconnect the battery ground at this time.
13. Find a grille/bumper location on driver side for the vehicle harness (similar position to battery cable mount). See Steps 8 and 9 for how to install. Route vehicle harness through grille or bumper and around, or through radiator bulkhead (drill 5/8" hole if needed) into engine compartment.
14. Route the wires that break out of the vehicle harness to the area behind the driver-side headlamp. Route rest of harness to the fire wall. Drill a 5/8" hole through the fire wall in a convenient location away from hot or moving engine parts.
15. Route brown/red and orange/black wire loom to motor relay.
16. Attach the brown/red and orange/black wires small ring terminals to separate small terminals on motor relay using a lock washer and #10-32 nut for each connection.
17. Route the 24" long orange/black wire with 3/8" ring terminal to battery NEGATIVE (-) terminal. **DO NOT attach wire to battery at this time.**

For MVP® installation: 2003 and Later - go to page 11
1999 to 2002 - go to page 13

18. At the hole through the fire wall, feed vehicle harness fuse holder through hole and then feed the plastic connector and harness through to the cab. Disassembly of the fuse holder may make it easier to pass through 5/8" hole.
19. Inside the cab, route vehicle harness connector to solenoid or CabCommand control and couple the connectors together.

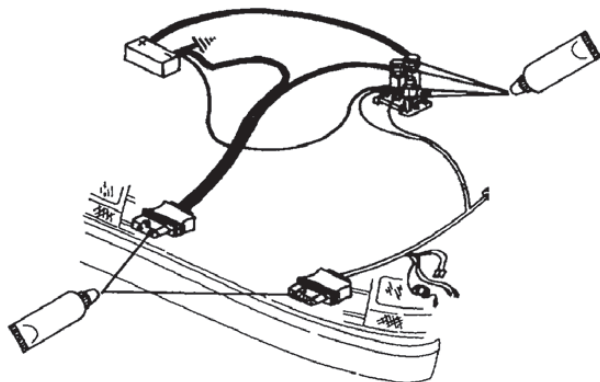

20. Attach the black hydraulic unit battery cable and the orange/black wire ring terminal to the NEGATIVE (-) battery terminal with the second battery cable adapter. Position cable and wire, and tighten battery adapter to 124–178 in-lb. Attach OEM battery cable to adapter, position cable, and hold adapter while tightening original battery bolt to 124–178 in-lb.
21. **2003 and Later** - The mid Bussed Electrical Center (BEC) is located to the left of the brake pedal. The upper left corner has two pins controlled by the ignition switch. One is fused for 10 Amps in run/start, the other is fused for 10 Amps in accessory/run.
1999 to 2002 - Locate an accessory wire capable of carrying 6 Amps in addition to existing circuit loads and controlled by the ignition (key) switch. Route the vehicle harness SFE-6 fuse holder red wire to this location and trim off any excess length of wire (keep fuse holder in system).
22. **2003 and Later** - Attach a receptacle to the red wire that will fit the blade in the BEC and plug in the connection.

1999 to 2002 - Open blue self-stripping connector and place the end of the red wire against the inner groove stop (end of wire must not extend from the closed connector), and the accessory wire in the outer groove. Close connector over the wires using a pliers and snap the locking tab in place.

DIELECTRIC GREASE (1/4 oz)
Part Number 56099

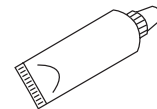

A larger tube (2 oz) of dielectric grease is available.
Part Number for larger tube is 49326.

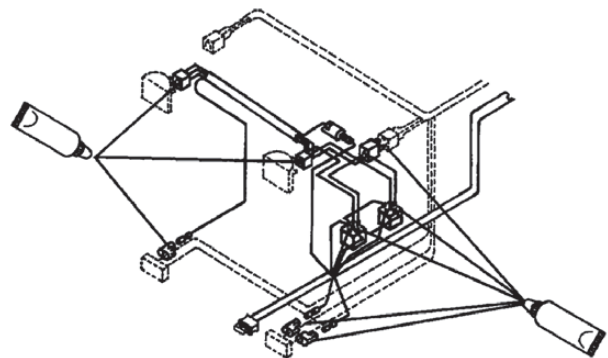

UNDER HOOD INSTALLATION

PLUG-IN HARNESS AND HEADLAMP RELAY INSTALLATION

Driver Side of Vehicle

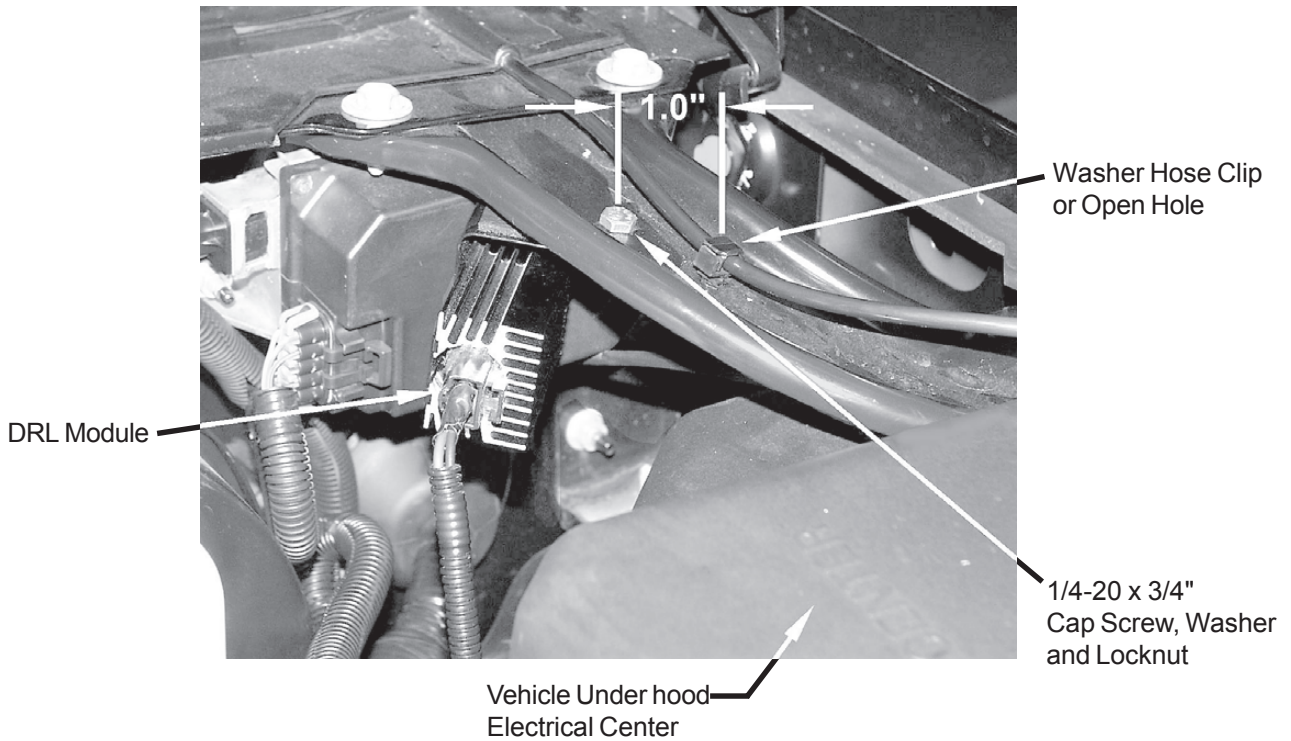

1. Use open hole in support bracket, or drill a 9/32" clearance hole, 1" from washer hose clip on the center line of the support bracket. Mount DRL module as shown in illustration, using 1/4-20 x 3/4" cap screw, washer and locknut. Plug in supplied cable assembly, and route to headlamp relays. Connect red and black wire to relays as shown in schematic on page 8 for 2003 and Later, page 9 for 1999 to 2002.

3. **1999 to 2002** - Strip the cut ends approximately 1/4", and install insulated receptacles.

2. **2003 and Later** - Skip to step 4.

1999 to 2002 - Modify the Park Lamp tap wire as shown below. Cut the brown Park Lamp wire approximately 10" from branch point at vehicle harness.

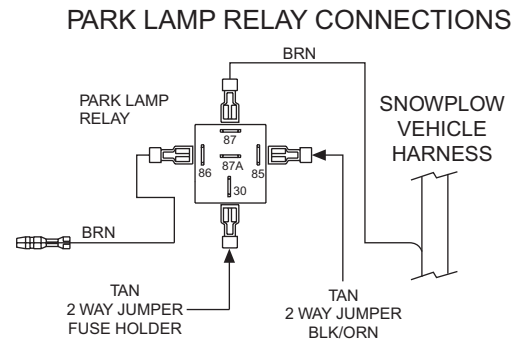
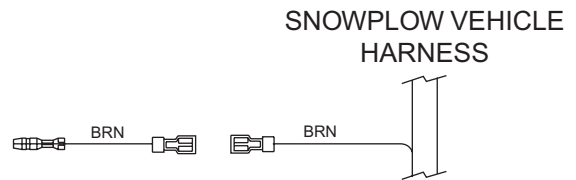
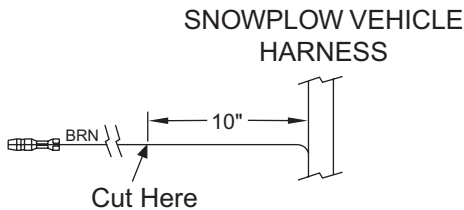

(Continued on next page)

UNDER HOOD INSTALLATION

PLUG-IN HARNESS AND HEADLAMP RELAY INSTALLATION (Continued)

4. In the engine compartment behind the driver side headlamp, insert wire bullets from snowplow vehicle harness into black bullet connectors (installed in step one of previous section) as follows:
 - Brown wire to parking lamp wire on driver side.
 - Gray wire to left turn signal wire on driver side.
5. Remove headlamp housing to access headlamp connectors on quad composite type headlamps. At the vehicle driver-side headlamp, remove the connectors from the headlamps and couple matching connectors with plug-in harness two 2-wire male plugs (plug-in harness found in harness kit). Attach plug-in harness headlamp connectors to headlamp terminals.
6. Route other end of plug-in harness along radiator bulkhead or over radiator shroud to passenger-side headlamps. Remove headlamp connectors. Couple matching connectors with plug-in harness male plugs. Attach plug-in harness headlamp connectors to headlamp terminals.
7. On the passenger side, insert purple wire bullet from plug-in harness into vehicle turn signal black bullet connector installed in step 1 on page 4.
8. At the driver-side headlamp, insert the purple wire bullet from the vehicle harness into the purple wire receptacle on the plug-in harness.
9. At driver-side headlamp, connect snowplow vehicle and plug-in harness wires with receptacles to relays (found in harness kit) as shown in wiring diagrams on following pages.
10. Place grommet around snowplow vehicle harness and insert into fire wall hole. Use cable ties (found in harness kit) to secure harnesses, relays and wires away from sharp edges, and hot or moving engine parts and to prevent accidental grounding of connections.
11. Use the pink self-stripping connector (found in harness kit) to attach the 24" long red wire with diode to the dark blue wire that feeds the DRL lamp.
12. Lubricate terminal cavities of both harness connectors with dielectric grease. **Give the dielectric grease tube to vehicle owner for future use.**

**PLEASE REFER TO A,Q&L ASSEMBLY
INSTRUCTIONS FOR ADDITIONAL INFORMATION
ON OPERATIONAL TESTS AND ADJUSTMENTS.**

See wiring diagrams on following pages.

2003 GM with DRLs – 12-Pin (White) Headlamp Kit 64078

Harness Type - H
With 12 Pin (White) Headlamp Kit
& SAE Headlamp Type HB-3 and HB-4

PASSENGER SIDE

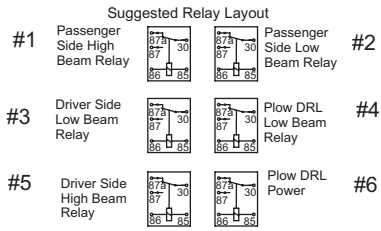
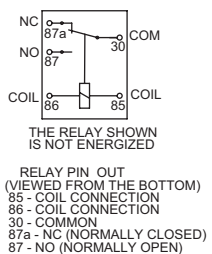
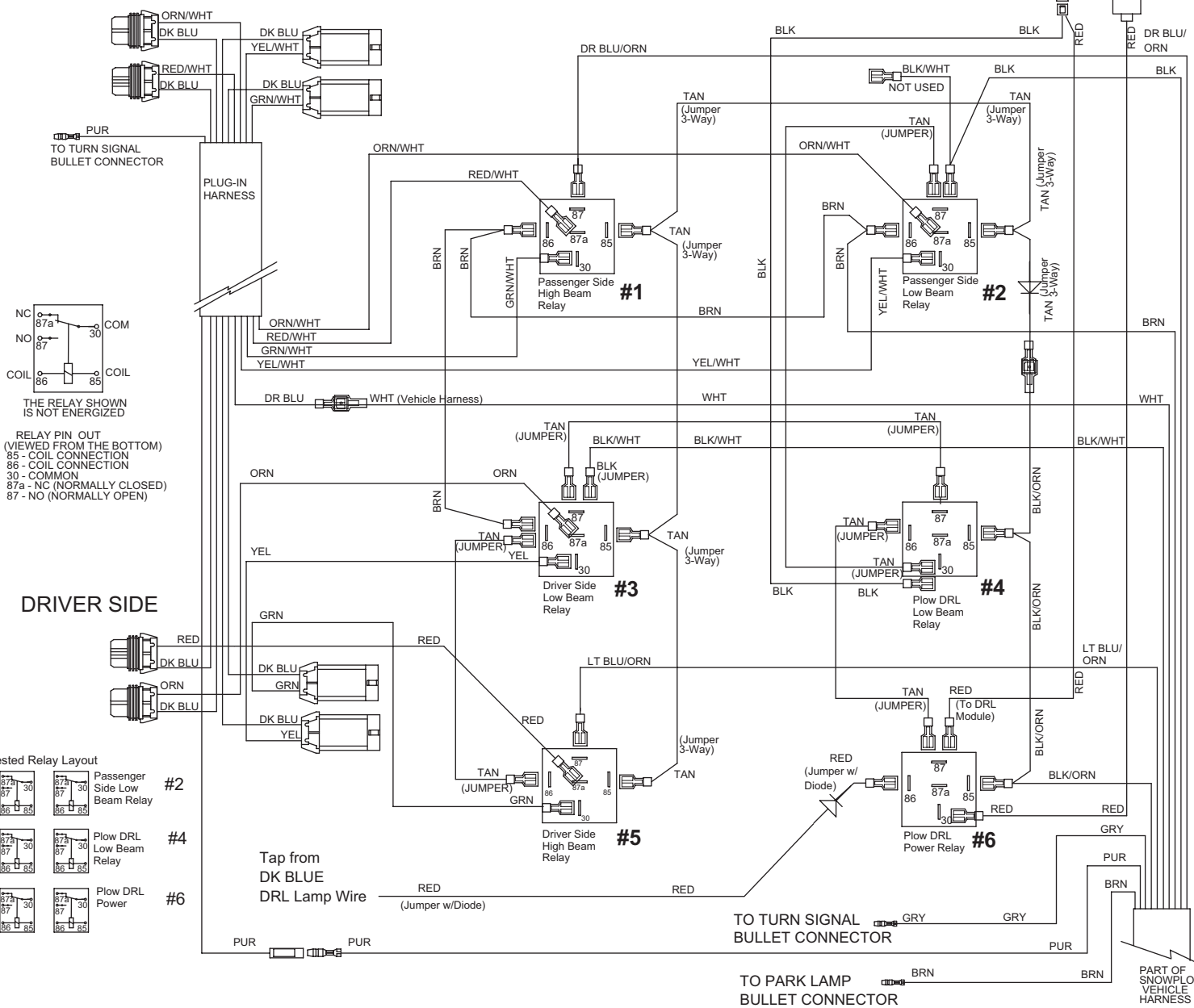

Tap from DK BLUE DRL Lamp Wire

TO TURN SIGNAL BULLET CONNECTOR

TO PARK LAMP BULLET CONNECTOR

PART OF SNOWPLOW VEHICLE HARNESS

WIRING DIAGRAM – STRAIGHT BLADE / MVP® BLADE

This page intentionally left blank.

2003 AND LATER INSTALLATIONS WITH DRLs

Use **64078 Headlamp Kit 12-Pin (White)**. (Factory wired headlamps for this application have a white strain relief where the cable enters the housing 61550-1 Headlamp Kit 12-Pin can be field converted, see page 17.)

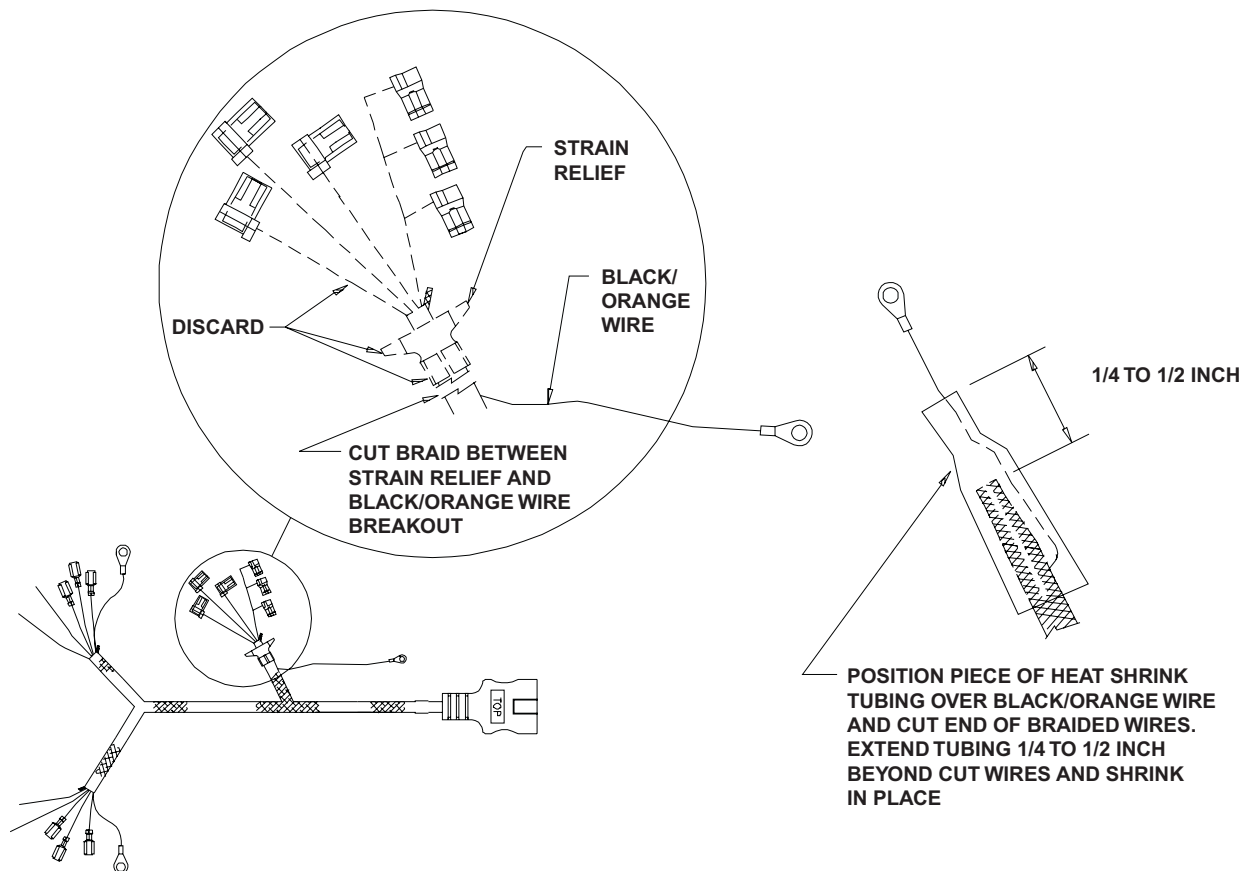

MVP® Installations Only

1. The 64078 12-pin (white) headlamp kit plow harness needs to be modified to remove the wires and terminals that normally connect to the hydraulic unit. Follow the diagram above for this modification.
2. The vehicle harness for the headlamps (no white tape on braid behind the mold) has been shortened and should be routed from the bumper/grille area to behind the driver-side headlamps for connection to the headlamp relays. (See diagram on next page.)
3. Attach wires from the modified vehicle harness and the plug-in harness as shown in the wiring diagram for your vehicle.
4. Attach the plow harness with the white tape on the mold provided in this kit to the hydraulic unit on the MVP® plow. Secure the harness to the side angle of the lift frame.

(Continued on next page.)

MVP® IN-CAB CONTROL WIRING (CONTINUED FROM PAGE 11)

2003 AND LATER INSTALLATIONS WITH DRLs (Continued)

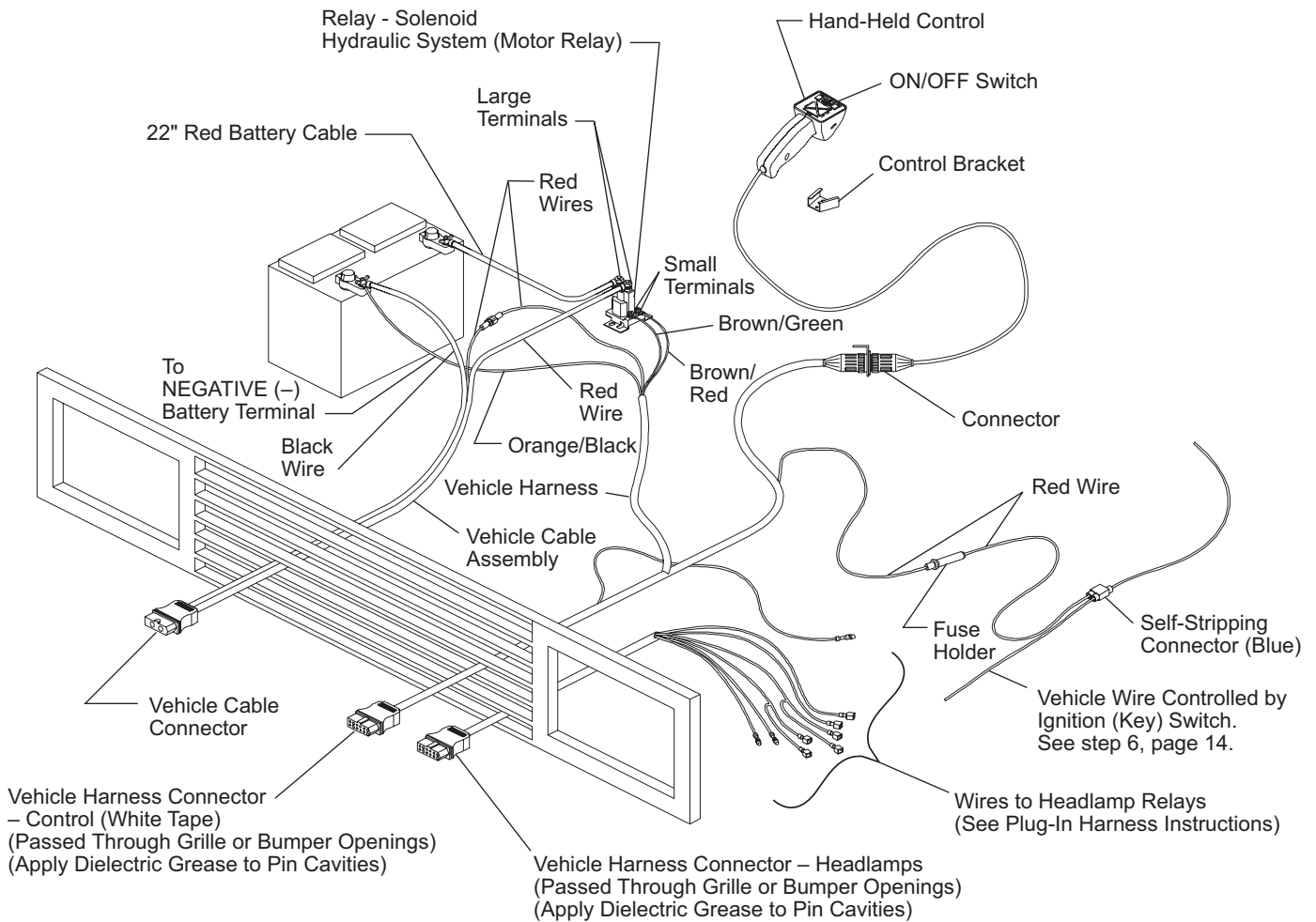

MVP® Installations Only (Continued)

5. On the vehicle, install the modified vehicle harness with the white tape on the braid routing it from the bumper/grille area to the cab and also to the motor relay.
6. Under the hood, make the connections at the motor relay as shown in the instructions on page 5 for your vehicle.
7. Secure both special vehicle harnesses behind the bumper/grille area.
8. Inform the owner/operator, that when attaching the plow to the vehicle, the two ends with the white tape are to be mated together. The two ends without the white tape are mated together.
9. Go to next page to finish installation.

VEHICLE HARNESS AND VEHICLE CABLE INSTALLATION

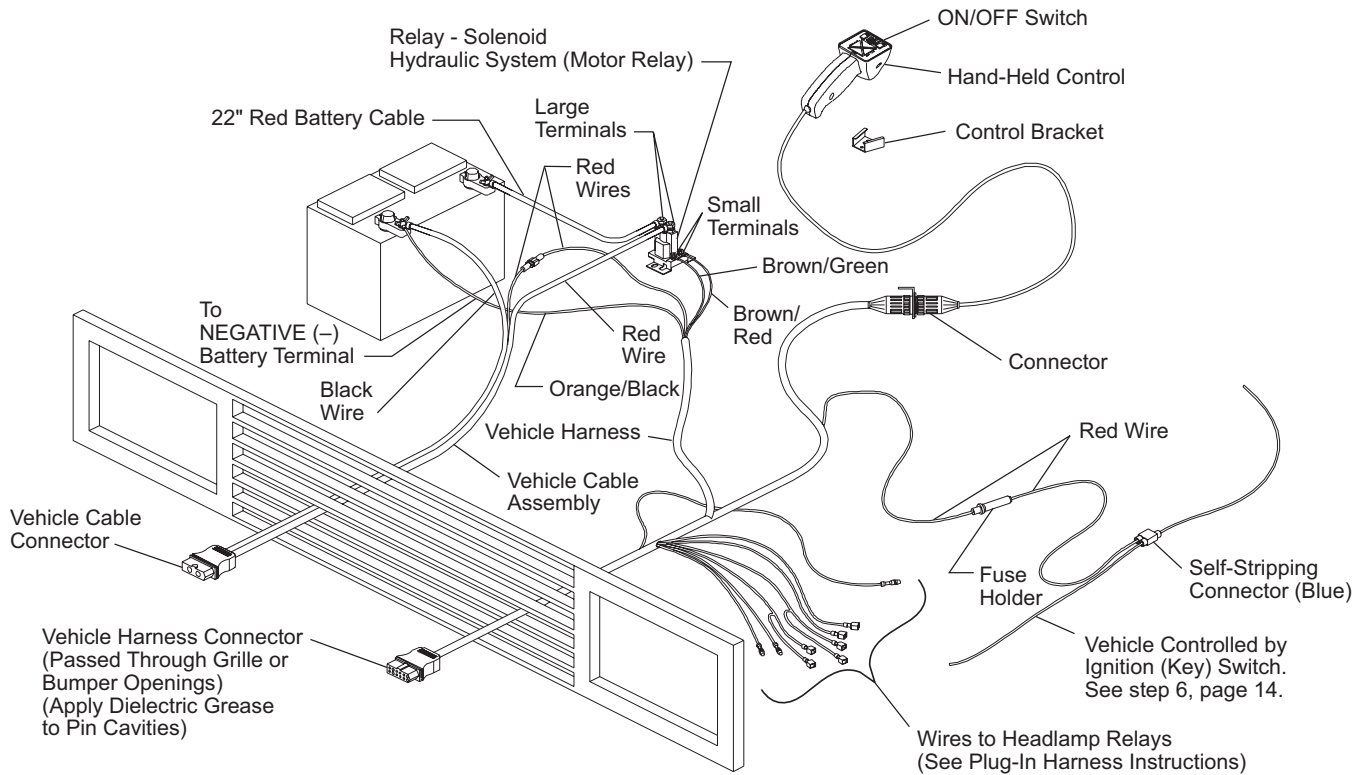

(Continued from page 5 or page 12.)

For 2003 and later MVP® installations, follow instructions on page 11 before proceeding with step 1 below.

For all MVP® installations 1999 to 2002, follow instructions beginning with step 1 below.

1. Remove the packing material from the end of the harness near the fuse. This will expose 10 socket-type terminals. Push the fuse holder through the fire wall hole and then carefully feed the end of the harness with the 10 terminals through to the cab.
2. Locate a connector bracket mounting position under the dash where it will not interfere with other equipment. Mount the connector bracket using #8 x 5/8" tapping screws and washers.

⚠ CAUTION

Do not alter, modify, or install additional components in shaded areas of the illustration below. Failure to comply may interfere with air bag deployment or cause injury to operator in an accident.

When choosing a location for your control, it should be mounted in easy reach of the vehicle operator and not restricting access to vehicle controls or vehicle instrumentation. Do not mount the control in areas prohibited by the vehicle manufacturer for crash worthiness. See the vehicle's body builders book, owner's manual, or service manual for details. The shaded areas in the illustration below show the most commonly restricted areas.

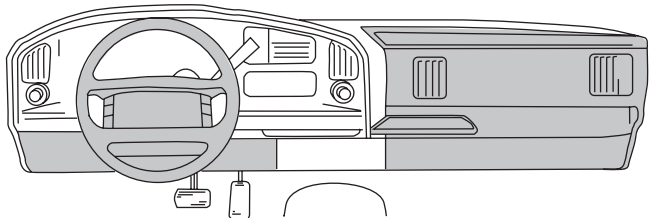

⚠ CAUTION

Before drilling holes, check to be sure that no vehicle wiring or other components could be damaged.

(Continued on next page.)

VEHICLE HARNESS AND VEHICLE CABLE INSTALLATION (Continued)

3. Feed the vehicle harness through the bracket.
4. Insert each of the 10 socket-type terminals into the connector housing. (See illustration below.)

Refer to the Table 1 below for under-dash vehicle harness connector pin assignments.

NOTE: A "snap" will be felt as the terminals are successfully inserted. An extraction tool is provided for removal of pin terminals if necessary.

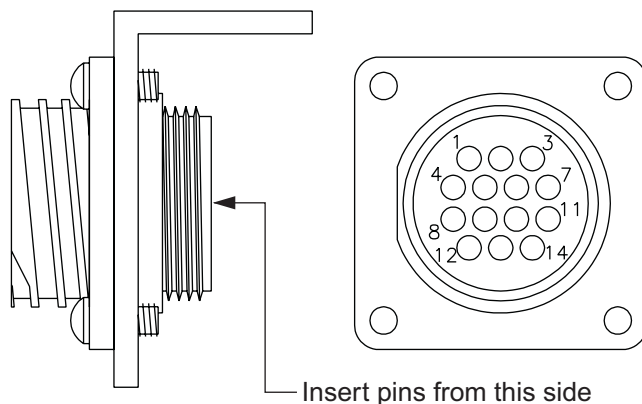

Table 1

Wire Color	Pin No.
Light Blue With Orange Stripe	1
Blue With Orange Stripe	2
Black With White Stripe	3
Light Green	4
Light Blue	5
White With Yellow Stripe	6
Brown With Red Stripe	7
Red	8
Orange With Black Stripe	9
Brown With Green Stripe	10

5. Secure the connector to the bracket with the provided #6-32 x 1/4" tapping screws and lock washers.
6. **2003 and Later** - The mid Bussed Electrical Center (BEC) is located to the left of the brake pedal. The upper left corner has two pins controlled by the ignition switch. One is fused for 10 Amps in run/start, the other is fused for 10 Amps in accessory/run.
1999 to 2002 - Locate an accessory wire capable of carrying 10 Amps in addition to existing circuit loads and controlled by the ignition (key) switch.
7. Route the 10-Amp fuse holder red wire to this location and trim excess length (leave the 10-Amp fuse holder in the system.)
8. **2003 and Later** - Attach a receptacle that will fit the blade in the BEC and plug-in connection.
1999 to 2002 - Open the blue, self-stripping connector and place the end of the red wire against the inner groove stop (end of wire must not extend from the connector when it is closed) and the accessory wire in the outer groove. Close the connector over the wires using a pair of pliers and snap the locking tab into place.
9. Install grommet around the harness at the fire wall hole if drilled. Install second grommet if hole was drilled in radiator bulkhead. Cable tie harness as required.
10. Under hood near motor relay, connect the female spade terminal on the small red wire from the vehicle cable to the male spade terminal on the red wire from the vehicle harness.
11. Attach the black hydraulic unit battery cable and the orange/black wire ring terminal to the NEGATIVE (-) battery terminal with the second battery cable adapter. Position cable and wire, and tighten battery adapter to 124–178 in-lb. Attach OEM battery cable to adapter, position cable, and hold adapter while tightening original battery bolt to 124–178 in-lb.
12. According to the headlamp kit to be installed for your vehicle, return to the appropriate page (6–9) to install plug-in harness.

ELECTRICAL SCHEMATIC – 2003 and Later MVP® Blade Hydraulics

Lit. No. 67803

15

October 31, 2003

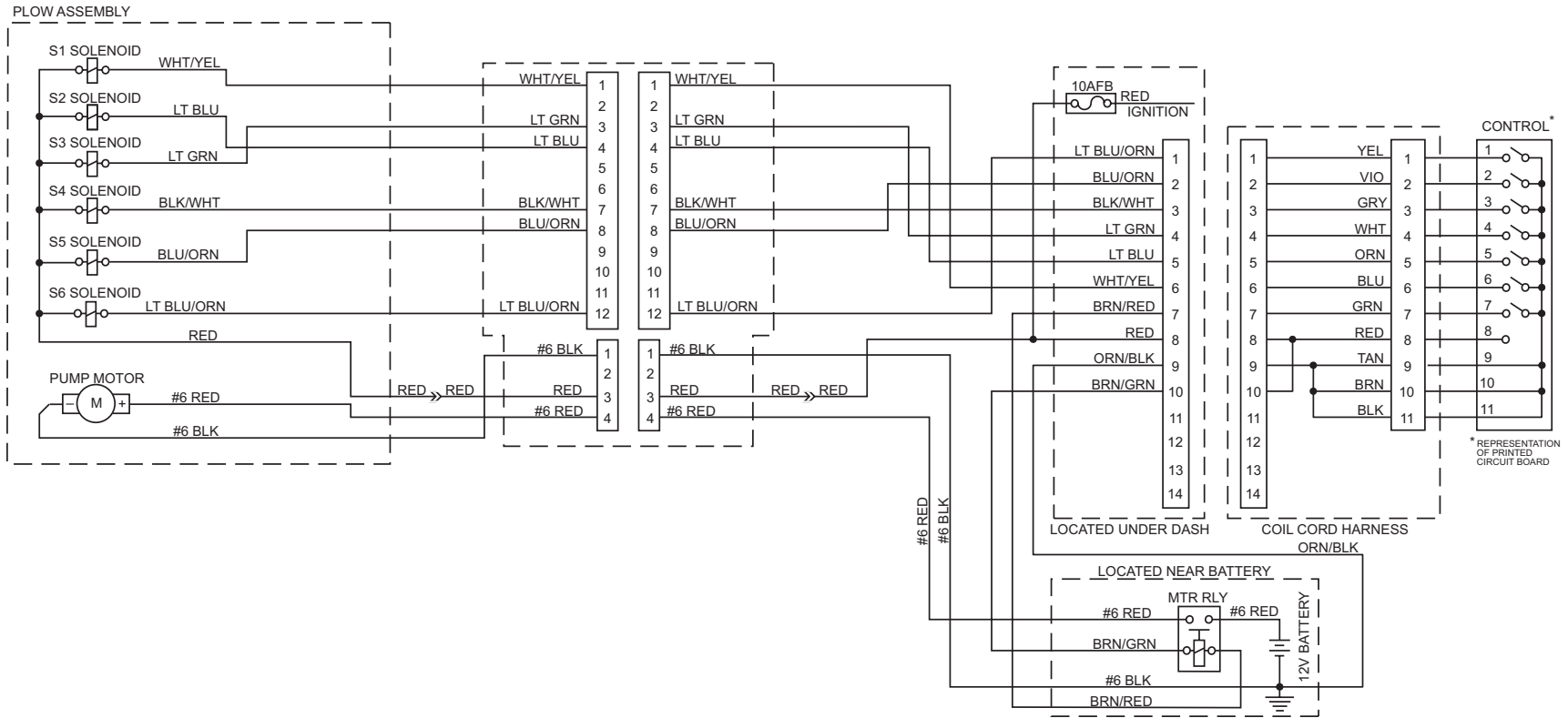

WIRING DIAGRAM – MVP® BLADE

ELECTRICAL SCHEMATIC – 1999 to 2002 MVP® Blade without DRLs

Lit. No. 67803

16

October 31, 2003

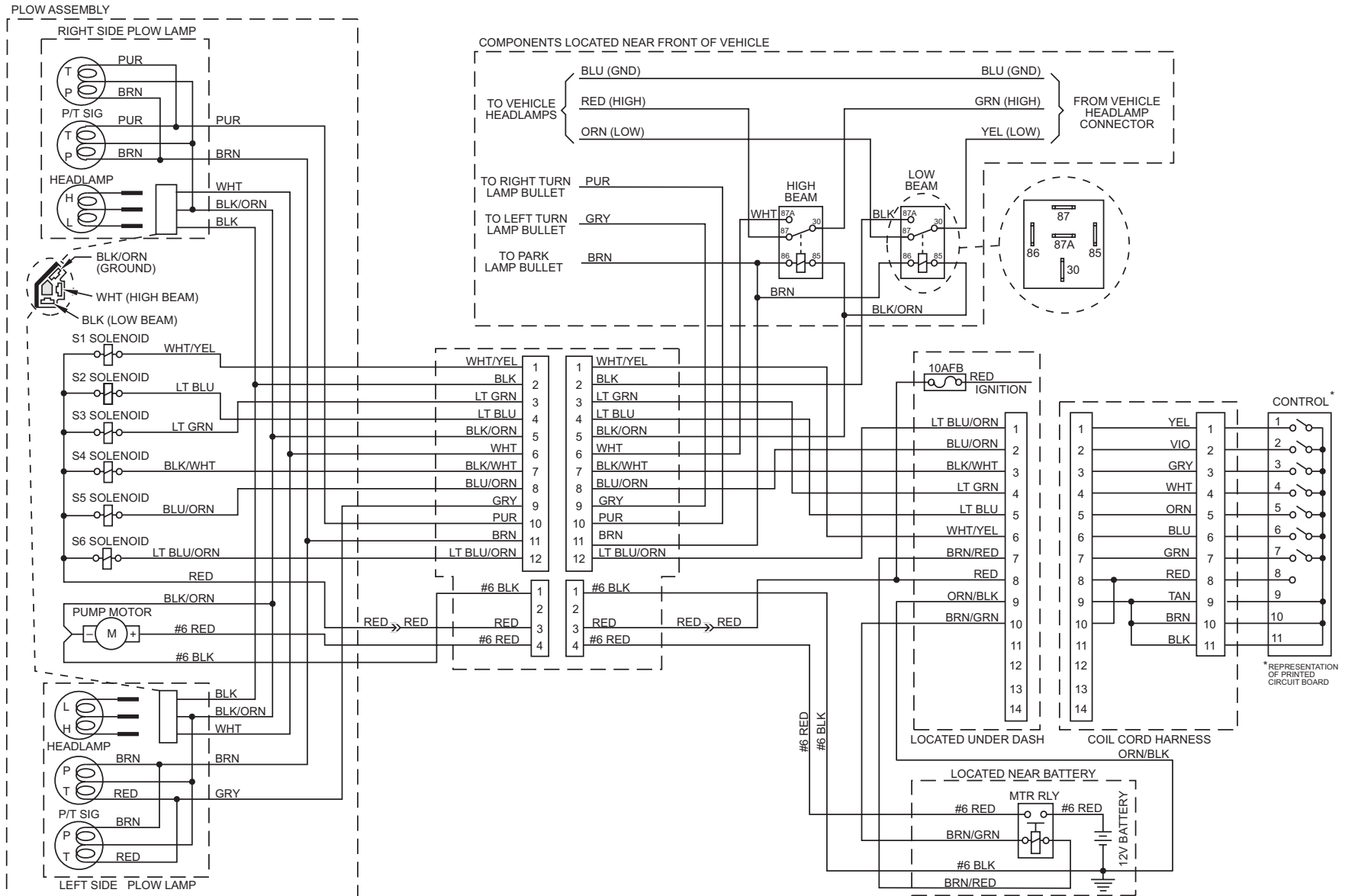

WIRING DIAGRAM – MVP® BLADE

12-PIN HEADLAMP KITS

61550-1 HEADLAMP KIT 12-PIN 64078 HEADLAMP KIT 12-PIN (WHITE)

The 64078 Headlamp Kit 12-Pin (White) is being introduced for use on 2003 GM Pickups and 2003 Dodge Ram Trucks.

Both these kits have the same housings and wiring harness. The insertion of the WHITE and LIGHT BLUE/ ORANGE or DARK BLUE/ORANGE wires into the seal beam connector is the difference between these two assemblies.

When wired for the 64078 kit at the factory, a white strain relief is inserted into the cable entrance opening to identify the internal wiring.

61550-1 Headlamp Kits can be field reworked into 64078 Headlamp Kits by switching the two wires in the sealed beam connector. See details below for correct positions of wires in connectors. If available, change strain reliefs to white to indicate that the internal wiring is changed.

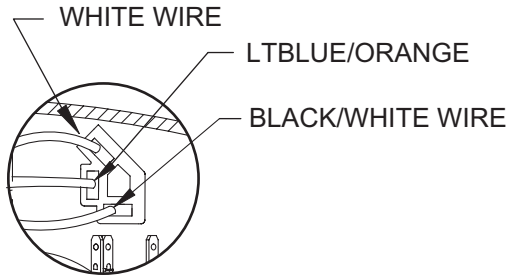
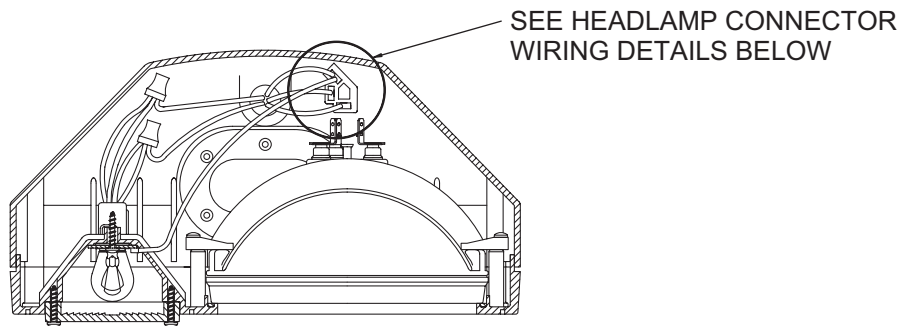

64078 12-Pin (White)
Driver Side

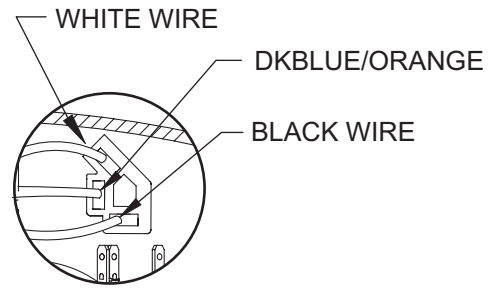

64078 12-Pin (White)
Passenger Side

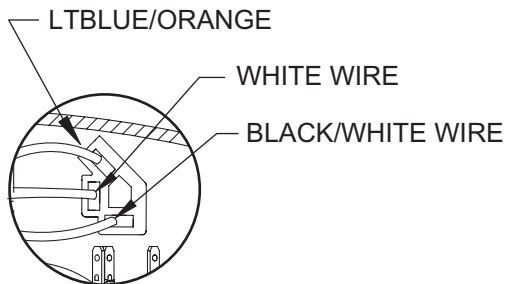

61550-1 12-Pin
Driver Side

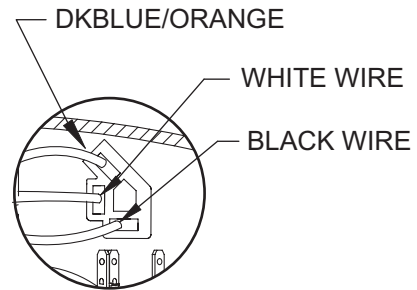

61550-1 12-Pin
Passenger Side



WESTERN PRODUCTS
P.O. BOX 245038
MILWAUKEE, WI 53224-9538

 A DIVISION OF DOUGLAS DYNAMICS, L.L.C.

Western Products reserves the right under its Product Improvement Policy to change construction or design details and furnish equipment when so altered without reference to illustrations or specifications used. Western Products and the vehicle manufacturer may require and/or recommend optional equipment for snow removal. Do not exceed vehicle ratings with a snowplow. Western Products offers a limited warranty for all snowplows and accessories. See separately printed page for this important information. The following are registered (®) trademarks of Douglas Dynamics, L.L.C.: MVP®, UltraMount®, and WESTERN®.