



WESTERN PRODUCTS
7777 NORTH 73RD STREET
P.O. BOX 23045
MILWAUKEE, WISCONSIN 53223

A DIVISION OF DOUGLAS DYNAMICS, INC.

Box No. 60520
Model No. 1390
F-250 & F-350 4x4
Diesel w/Super Cool
F-350 4x4 w/Front Mono-Beam Axle
Mount Unit

INSTALLATION INSTRUCTIONS

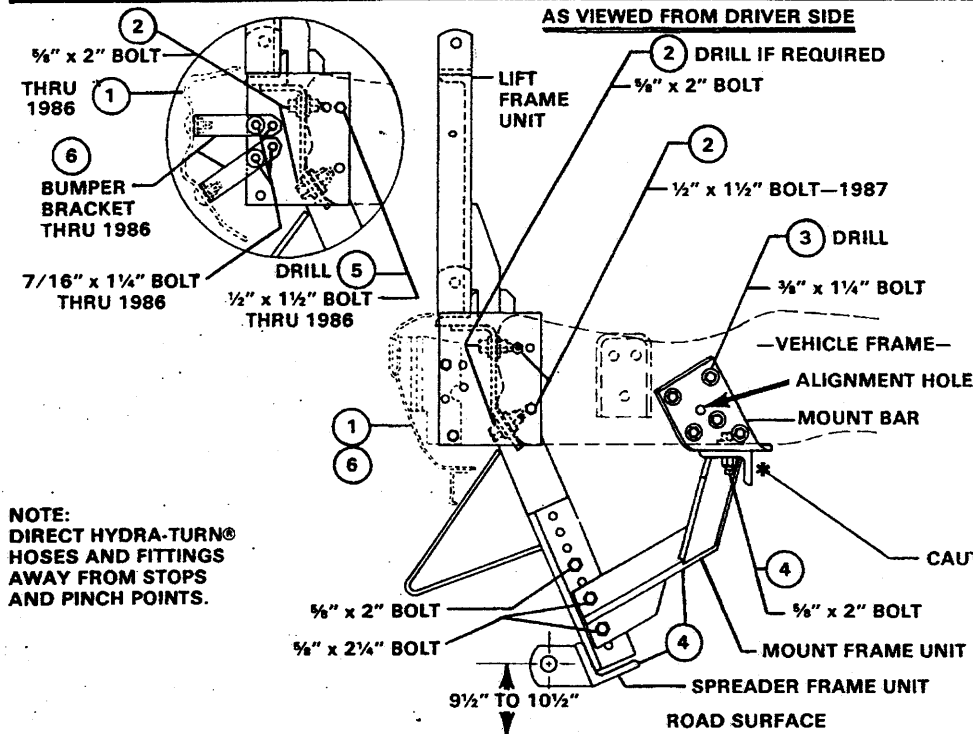

SIZE	TORQUE IN FOOT POUNDS		
	GRADE 2	GRADE 5	GRADE 8
1/4 - 20	6	8	13
5/16 - 18	11	18	28
3/8 - 16	15	31	46
7/16 - 14	24	46	68
1/2 - 13	30	50	75
9/16 - 12	45	75	115
5/8 - 11	65	110	165
3/4 - 10	93	150	225
7/8 - 9	130	250	370
1 - 8	202	378	561
	300	563	863

METRIC GRADE 8.8		TORQUE IN FOOT POUNDS	
SIZE	TORQUE	SIZE	TORQUE
M 6	7	M12	60
M 8	17	M14	95
M10	35	M16	155

These torque values apply to lift-mount fasteners except those noted in the instructions where motion is desired.

MINIMUM VEHICLE RECOMMENDATIONS	
Aux. Light Kit	
H.D. Alternator	
H.D. Battery	
H.D. Suspension	

NOTE:
DIRECT HYDRA-TURN®
HOSES AND FITTINGS
AWAY FROM STOPS
AND PINCH POINTS.

CAUTION: CLEARANCE BETWEEN
PITMAN ARM AND MOUNT
MUST BE 3/8" MINIMUM.

IMPORTANT: Read instructions before assembling. Bolts should be finger tight until the installation is completed to allow sufficient adjustment for aligning holes and locating parts to vehicle frame. Preventive maintenance can prevent accidents. Regularly inspect all components and repair or replace any worn, loose, or damaged parts immediately. Remember to use standard methods and practices when attaching snowplow including wearing safety glasses during drilling.

**LIFT-MOUNT ASSEMBLY:
1987 & LATER VEHICLES**

1. Remove the bumper with brackets attached from vehicle frame.
2. Attach the lift frame unit loosely to the side slots of the vehicle frame horn using 1/2" x 1 1/2" bolts, flat washers to slots and locknuts. Insert top bolt with flat washer from inside of frame and secure with locknut on outside. Insert bottom bolt from outside of frame and secure with flat washer and locknut on inside. Install 3/8" x 2" bolts, flat washers and locknuts to end flange of frame and lift frame unit slots. **VEHICLES WITHOUT SLOTS IN END FLANGE OF FRAME:** With lift frame unit tight against end flange of frame, drill two (2) 3/8" holes for 3/8" bolts.

ALL VEHICLES

3. Following the diagram, with mount bar tight to bottom of frame rail, locate alignment hole in mount bar to existing small hole in frame rail and secure with 3/8" x 1" Thread Forming Screw. Tighten screw only tight enough (10 ft. lbs.) to hold mount bar in place. Using mount bar as a template, accurately drill remaining five (5) holes to 25/64" (.391) diameter. Remove mount bar and redrill holes to 37/64" (.578). Insert Blind Nuts into frame holes. Fasten mount bar to frame rail using **THREAD FORMING SCREW** in alignment hole. Secure mount bar with five (5) 3/8" x 1 1/4" bolts and lock washers torqued to 30 ft. lbs. **NOTE:** If alignment screw interferes when tightening adjacent bolt, remove alignment screw **ONLY AFTER** torquing other four bolts. **If the vehicle has an Evaporator Canister that interferes with the mount frame, remove the canister and install furnished bracket to four threaded holes using existing self-tapping fasteners. Secure Evaporator Canister to the rear side of bracket using furnished 5/16" x 1" bolts, flat washers and locknuts. CAUTION:** Maintain adequate clearance horizontally and vertically between hoses, steering linkage at maximum right turn, alternator drives, oil cooler lines and do not collapse evaporator hose.
4. Attach mount frame unit to mount bars using 3/8" x 2" bolts, flat washers to slots and locknuts. Place spreader frame between lift frame angles and the mount frame angles, keeping the center of the coupling lugs between 9 1/2" and 10 1/2" from the road. (Or as high as possible if less than 9 1/2".) Fasten together using 3/8" x 2" bolt and locknut in top hole of spreader and two (2) 3/8" x 2 1/4" bolts and locknuts thru mount frame holes per side.

**TIGHTEN ALL BOLTS TO CORRESPONDING TORQUE VALUES NOTED IN FASTENER TORQUE CHART.
CHECK BETWEEN PITMAN ARM AND MOUNT FOR MINIMUM CLEARANCE SHOWN IN DIAGRAM ABOVE.**

1987 & LATER VEHICLES

6. To replace bumper: Loosen bolts holding halves of bumper brackets together, slide frame attaching half towards outer end of bumper 1/4". Replace the bumper to lift frame aligning bumper bracket holes to matching holes in the lift frame side plates using existing fasteners (torque per chart.) Position bumper and torque bolts holding bracket halves together.

LIGHT KIT ASSEMBLY 1987 & LATER VEHICLES — Use Box No. 60740 Headlamp Kit - 4 Wire and Box No. 60770 Harness/Bracket Kit - HB1 (9004). 1988 and Later — Mount Toggle Switch in Illa Control Floor Bracket.

Form No. 13372-8810

THRU 1986 VEHICLES

1. Remove the bumper from the vehicle.
2. Attach the lift frame unit loosely to the vehicle frame using 3/8" x 2" bolts, flat washers and locknuts. (Drill holes for side plates as noted in Step 5.)

THRU 1986 VEHICLES — See diagram in circle above.

5. Drill 1/2" hole in frame using upper rear hole in lift frame side plate as a guide. Fasten with furnished 1/2" x 1 1/2" bolts, flat washer to frame and locknut.
6. Attach long leg of bumper bracket to outside of lift frame with short leg towards center of vehicle. Fasten with 7/16" x 1 1/4" bolts, flat washers to slots and locknuts. Attach bumper to brackets with existing fasteners. Torque all fasteners per above chart.

LIGHT KIT ASSEMBLY THRU 1986 VEHICLES — Use Box No. 60740 Headlamp Kit - 4 Wire and Box No. 60745 Harness/Bracket Kit - 2B/2D.

Box No. 60520
 Model No. 1390
 F-250 & F-350 4x4
 Diesel w/Super Cool
 F-350 4x4 w/Front Mono-Beam Axle
 Mount Unit

PARTS DIAGRAM & LIST

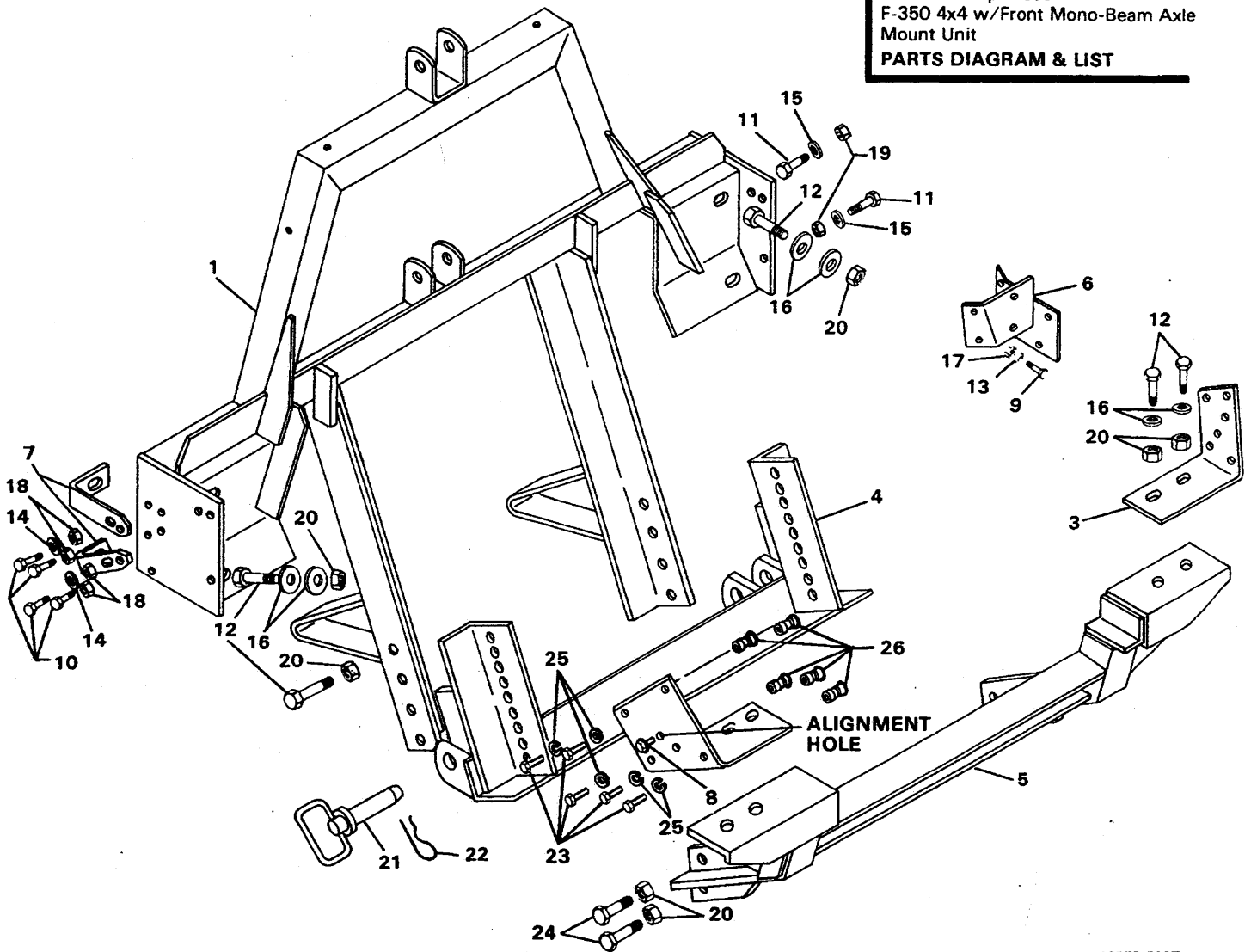

13373-8907

13374-8810

Item	Part Number	Quantity	Description
1	60615	1	Lift Frame Unit
2	60517	1	Mount Bar — Driver Side
3	60518	1	Mount Bar — Curb Side
4	59925	1	Spreader Frame Unit
5	60519	1	Mount Frame Unit
6	60495	1	Evaporator Bracket
7	60624	4	Bumper Brackets (Use on 1986 and Earlier Vehicles)
8	93169	2	Thread Forming Capscrew — 3/8"-16 x 1" Long
9		4	Capscrew — 5/16"-18 x 1" Long
10	90066	8	Capscrew — 7/16"-14 x 1-1/4" Long — Grade 5
11	90100	4	Capscrew — 1/2"-13 x 1-1/2" Long — Grade 5
12	90129	10	Capscrew — 5/8"-11 x 2" Long — Grade 5
13		4	Flat Washer — 5/16"
14		4	Flat Washer — 7/16"
15		4	Flat Washer — 1/2"
16		12	Flat Washer — 5/8"
17	91332	4	Locknut — 5/16"-18 — Nylon Insert Type
18	91334	8	Locknut — 7/16"-14 — Nylon Insert Type
19	91335	4	Locknut — 1/2"-13 — Nylon Insert Type
20	91337	14	Locknut — 5/8"-11 — Nylon Insert Type
21	93028	2	Hitch Pin — 1" x 3-1/2" Long
22	91965	2	Hairpin Cotter — 5/32" x 2-15/16" O/A Length
23	90040	10	Capscrew — 3/8"-16 x 1-1/4" Long — Grade 5
24	90130	4	Capscrew — 5/8"-11 x 2-1/4" Long — Grade 5
25		10	Lock Washer — 3/8"
26	91574	10	Blind Nut — 3/8"-16

NOTE: Only those items indicated with a PART NUMBER are available for service.

**INSTALLATION INSTRUCTIONS
FOR IIIa CONTROL
FORD 1980 & LATER**

1988 & LATER VEHICLES

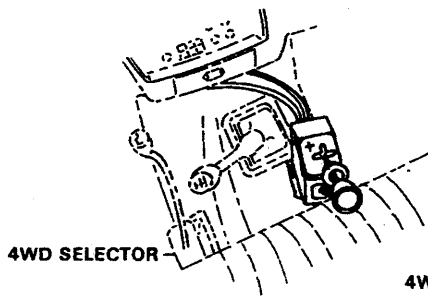

MANUAL TRANSMISSION

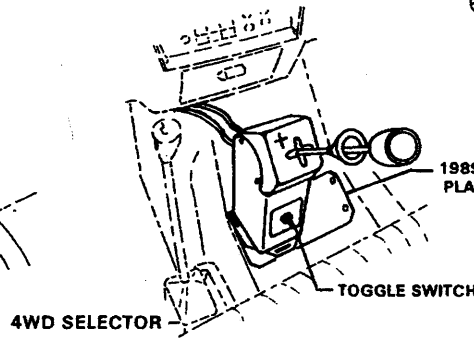

AUTOMATIC TRANSMISSION

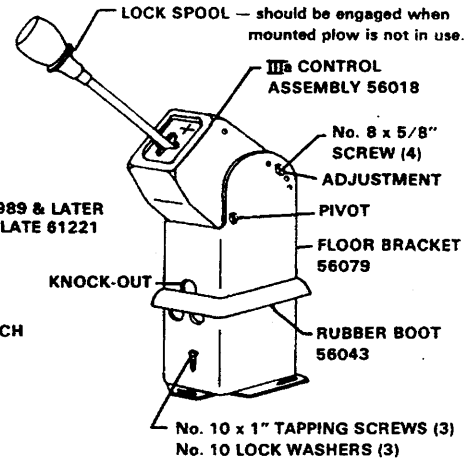

1. Remove top knock-out in front of Floor Bracket to receive Light Kit Toggle Switch. Temporarily assemble IIIa Control to Floor Bracket using four (4) No. 8 x 5/8" long hex head screws.
2. Position assembly as shown in sketch above: AUTOMATIC TRANSMISSION on left side of tunnel (1989 vehicles — position plate under Floor Bracket and center plate on top of tunnel.) MANUAL TRANSMISSION on right side of tunnel. With seat in forward position, verify that IIIa Control lever will clear all vehicle components.
3. CHECK underneath hole locations for wires or other interference before drilling. Using holes in plate as a template, drill five (5) 9/64" holes. OR Using bracket as template, drill 9/64" holes in center of each slot (3). Drilling in center of slots will allow bracket to be rotated to desired position. Loosely attach floor bracket with three (3) No. 10 x 1" tapping screws and lock washers. Secure remaining two holes in plate with one screw and lock washer from hydraulics box and another set from Lift-Mount box.
4. Remove IIIa Control and slide Rubber Boot over top of bracket. Pass control cables through holes drilled in fire wall per hydraulic system instructions. Place Control in bracket in desired position and secure. Rotate assembly to desired position and tighten mounting screws. Slide Rubber Boot down to cover screws.

1987 VEHICLES

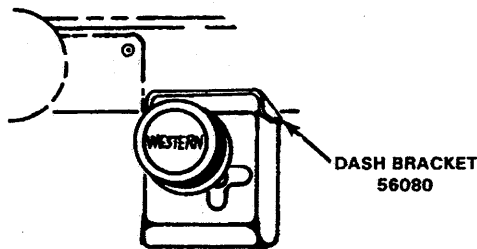

1987 & LATER VEHICLES

1. Secure dash bracket to the IIIa Control using four (4) No. 8 x 5/8" long hex head screws.
2. Locate IIIa Control, as shown, to the right of the steering column removable lower dash panel next to the dash reinforcement or wherever is most convenient. The bracket should fit fairly flat against the bottom surface of the dash. Verify that IIIa Control lever will clear vehicle components in all positions.
3. Mark this location.
4. Remove the bracket from the IIIa Control. Place the bracket in the selected location under the dash and mark all four (4) holes.
5. Check for adequate drill clearance before drilling holes. Drill 1/8" diameter holes into the dash to align to the holes in the bracket. Secure using No. 10 sheet metal screws and lock washers.
6. Place IIIa Control into bracket and fasten in desired position.

1986 & EARLIER

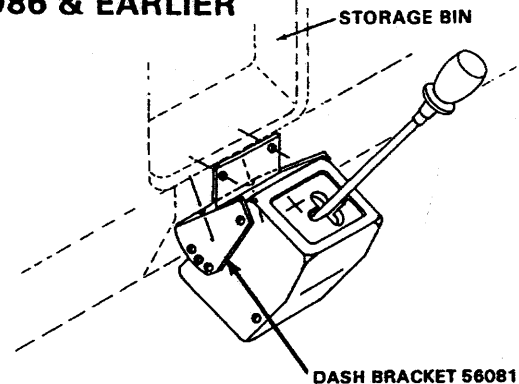

1986 & EARLIER

1. Secure dash bracket to the IIIa Control using four (4) No. 8 x 5/8" long hex head screws.
2. Locate IIIa Control, as shown, below the storage bin or wherever is most convenient. Position the brackets so that the top and bottom edges contact the dash (bend may be opened to permit closer fit). Verify that IIIa Control lever will clear vehicle components in all positions and for adequate drill clearance before drilling holes.
3. Mark and drill two (2) 1/8" holes in the dash to align to top holes in the bracket.
4. Remove the bracket from the IIIa Control and fasten it to the dash using two (2) No. 10 sheet metal screws and lock washers.
5. Mark and drill two (2) holes into the bottom flange of the dash to align to the holes in the bracket. Secure using No. 10 sheet metal screws and lock washers.
6. Place IIIa Control into bracket and fasten in desired position.

**A-FRAME STOP
MODIFICATION INSTRUCTIONS**

With snowplows mounted to vehicles having small tire size options, the blade lift may be less than desirable. If this condition exists on any installation, the height of blade lift can be increased by cutting and rewelding the A-Frame stops on the mount as shown in the sketch below.

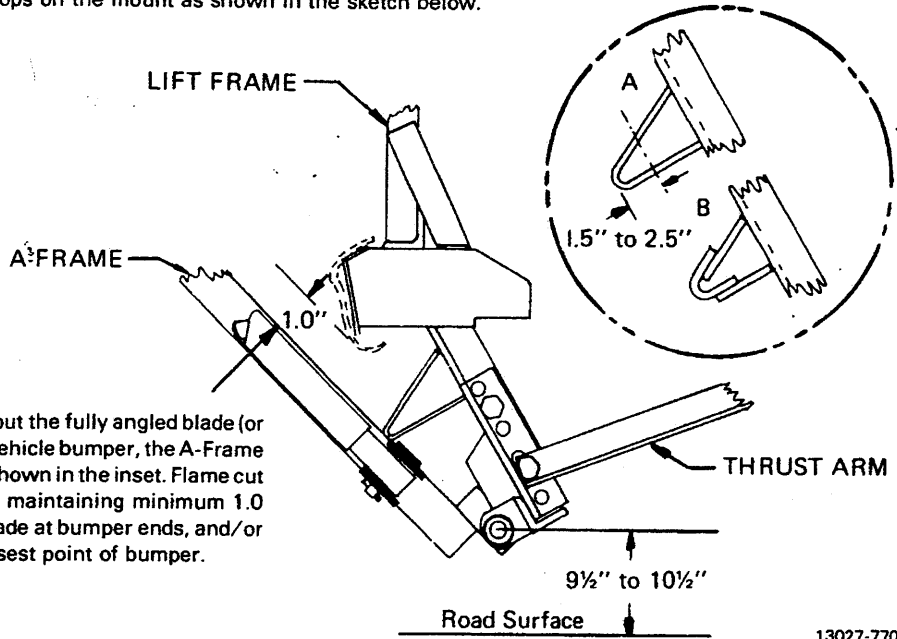

To gain maximum lift without the fully angled blade (or the A-Frame) striking the vehicle bumper, the A-Frame stops may be modified as shown in the inset. Flame cut at "A" and reweld at "B" maintaining minimum 1.0 inch clearance between blade at bumper ends, and/or between A-Frame and closest point of bumper.

13027-7707

**INSTALLATION INSTRUCTIONS
FOR 59700 BLADE GUIDE ASSEMBLY**

The following instructions simply outline the attachment of this blade guide assembly.

- Step 1. Lower blade to ground level.
- Step 2. If hole is not pre-drilled, drill one 11/32" hole, 1-3/16" down and 1" out on the outside rib of the blade. See diagram below.
- Step 3. Insert pointed end of clamp into coil of guide. Attach guide to rib using top hole of clamp. Secure assembly using supplied 5/16" x 1" bolt and locknut. Tighten until guide will stand alone perpendicular to road surface.
- Step 4. If hole is not pre-drilled, use lower hole of clamp as locator, drill bottom hole 11/32".
- Step 5. Bolt lower hole in place. Finish securing top bolt.
- Step 6. Attach other side following above steps.

Pictorial view supplied below. Remember to use standard methods and practices in attaching blade guides including wearing safety glasses during drilling.

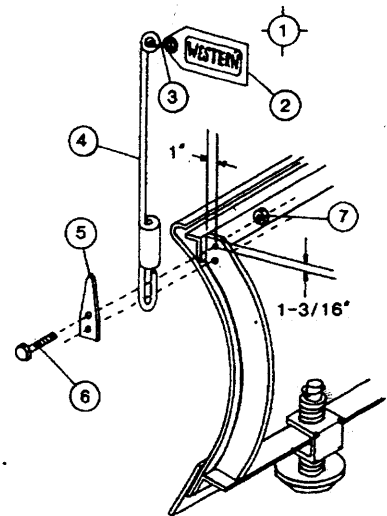

**PARTS LIST
59700 — BLADE GUIDE ASSEMBLY**

Item	Part No	Quan.	Description
1	59697	2	Blade Guide Rod, S-Hook & Flag
2	59694	1	Flag
3	59696	1	S-Hook
4	59691	1	Blade Guide Rod
5	59946	2	Clamp
6		4	Cap screw — 5/16"-18 x 1" Gr.2
7		4	Locknut - 5/16"-18 Nylon Insert

13009-7911

The following are registered® and unregistered™ Trade Marks of Douglas Dynamics, Inc.
WESTERN® ISARMATIC® Hydra-Turn® Roll-Action™ PRO-GUARD™

Western reserves the right under its Product Improvement Policy to change construction or design details and furnish equipment when so altered without reference to illustrations or specifications used herein.