



December 1998
No. 21936

MECHANIC'S GUIDE

Unimount^{SYSTEM}
SNOWPLOWS

Featuring the
ISARMATIC[®] Hydraulic System

⚠ CAUTION

Read this manual before servicing the snowplow.

TABLE OF CONTENTS

PREFACE

Preface	3
ISARMATIC® Hydraulic System	6
Product Specifications	6
Required Tools	6
Hydraulic Hose Routing	7
Hydraulic Unit Parts Diagram	8
Solenoid Cartridge Valve Identification and Location	9
Vehicle Harness and Vehicle Cable Location	10
Operating the Snowplow	11
Theory of Operation	13
Hydraulic and Electrical Schematics	14
Electrical Schematic	15
Hydraulic Schematic	17
Angle Right	18
Angle Left	20
Raise	22
Lower	24
Hold in Raise Position	26
Striking An Object While Plowing – Right Cylinder Retracts	27
Striking an Object While Plowing – Left Cylinder Retracts	28
Headlamps – Plow Not Connected – Vehicle Only	29
High Beam Headlamps With Plow Connected to Vehicle	31
Low Beam Headlamps With Plow Connected to Vehicle	33
Troubleshooting Guide	35

This guide has been prepared to assist the trained mechanic in the service of WESTERN® snowplows. It also provides safety information and recommendations. We urge all mechanics to read this manual carefully before attempting to service the WESTERN snowplow equipment covered by this guide.

Service of your WESTERN snowplow equipment is best performed by your local Western Products outlet. They know your snowplow best and are interested in your complete satisfaction.

SAFETY INFORMATION

⚠ WARNING

Indicates a potentially hazardous situation that, if not avoided, could result in death or serious personal injury.

⚠ CAUTION

Indicates a situation that, if not avoided, could result in minor personal injury and/or damage to product or property.

NOTE: Identifies tips, helpful hints and maintenance information the owner/operator should know.

BEFORE YOU BEGIN

⚠ WARNING

Lower blade when vehicle is parked. Temperature changes could change hydraulic pressure, causing the blade to drop unexpectedly or damaging hydraulic components. Failure to do this can result in serious personal injury.

⚠ WARNING

Remove blade assembly before placing vehicle on hoist.

⚠ WARNING

Do not exceed GVWR or GAWR including blade and ballast. The rating label is found on the driver-side vehicle door cornerpost.

- Park the vehicle on a level surface, place shift lever in PARK or NEUTRAL and set parking brake.
- Leave the snowplow mounted on the vehicle and lowered for most service procedures, unless told otherwise.

PERSONAL SAFETY

- Wear only snug-fitting clothing while working on your vehicle or snowplow.
- Do not wear jewelry or a necktie, and secure long hair.
- Be especially careful near moving parts such as fan blades, pulleys and belts.
- Wear safety goggles to protect your eyes from battery acid, gasoline, dirt and dust.
- Avoid touching hot surfaces such as the engine, radiator, hoses and exhaust pipes.
- Always have a fire extinguisher handy, rated BC for flammable liquids and electrical fires.

VENTILATION

⚠ WARNING

Vehicle exhaust contains deadly carbon monoxide (CO) gas. Breathing this gas, even in low concentrations, could cause death. Never operate a vehicle in an enclosed area without venting exhaust to the outside.

If you work on the vehicle or snowplow in a garage or other enclosed area, be sure to vent exhaust gas directly to the outside through a leakproof exhaust hose.

FIRE AND EXPLOSION

⚠ WARNING

Gasoline is highly flammable and gasoline vapor is explosive. Never smoke while working on vehicle. Keep all open flames away from gasoline tank and lines. Wipe up any spilled gasoline immediately.

Be careful when using gasoline. Do not use gasoline to clean parts. Store only in approved containers away from sources of heat or flame.

HYDRAULIC SAFETY

⚠ WARNING

Hydraulic oil under pressure could cause skin injection injury. If you are injured by hydraulic oil, get medical treatment immediately.

- Always inspect hydraulic components and hoses before using. Replace any damaged or worn parts immediately.
- If you suspect a hose leak, DO NOT use your hand to locate it. Use a piece of cardboard or wood.

SAFETY INFORMATION

BATTERY SAFETY

⚠ CAUTION

Batteries normally produce explosive gases which can cause personal injury. Therefore, do not allow flames, sparks or lit tobacco to come near the battery. When charging or working near a battery, always cover your face and protect your eyes, and also provide ventilation.

Batteries contain sulfuric acid which burns skin, eyes and clothing.

Disconnect the battery before removing or replacing any electrical components.

Please become familiar with and make owners knowledgeable of the Warning and Instruction labels on the back of the blade!

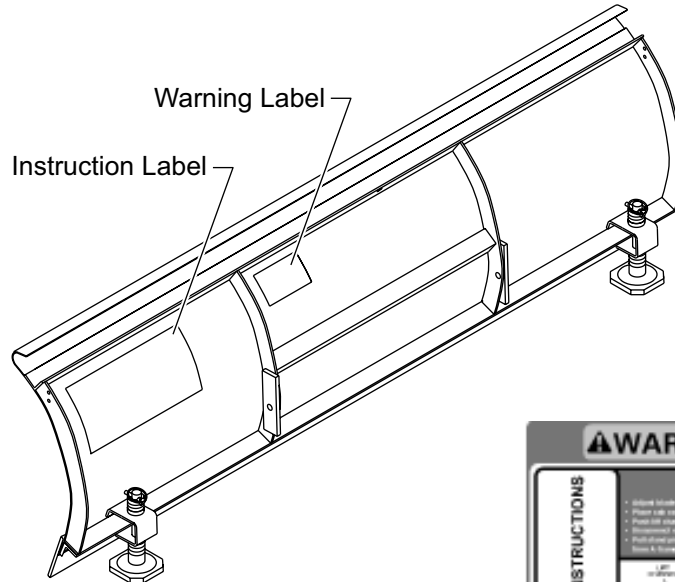

Warning Label

⚠ WARNING
LOWER BLADE WHEN VEHICLE IS PARKED. REMOVE BLADE ASSEMBLY BEFORE PLACING VEHICLE ON HOIST.
DO NOT EXCEED GVWR OR GAWR INCLUDING BLADE AND BALLAST.
⚠ CAUTION
READ OWNER'S MANUAL BEFORE OPERATING OR SERVICING SNOWPLOW.
TRANSPORT SPEED SHOULD NOT EXCEED 45 MPH. REDUCE SPEED UNDER ADVERSE TRAVEL CONDITIONS.
PLOWING SPEED SHOULD NOT EXCEED 10 MPH.
SEE YOUR WESTERN OUTLET FOR APPLICATION RECOMMENDATIONS.

Instruction Label

⚠ WARNING: TO AVOID PERSONAL INJURY, FOLLOW STEPS IN SEQUENCE.			
INSTRUCTIONS 	REMOVING PLOW STEP 1 - Lower blade to storage position. - Place side anchor in "L" position. - Push lift cylinder down. - Disconnect electrical system. - Push front pin and back pin release and lock & turn.	STEP 2 - Release blade from "L" position. - Push lift cylinder up. - Push front pin and back pin release and lock & turn.	STEP 3 - Disconnect blade from "L" position. - Push lift cylinder up. - Push front pin and back pin release and lock & turn.
STEP 4 - Push side anchor in "L" position. - Push lift cylinder down. - Disconnect electrical system. - Push front pin and back pin release and lock & turn.	STEP 5 - Push side anchor in "L" position. - Push lift cylinder down. - Disconnect electrical system. - Push front pin and back pin release and lock & turn.	STEP 6 - Push side anchor in "L" position. - Push lift cylinder down. - Disconnect electrical system. - Push front pin and back pin release and lock & turn.	STEP 7 - Push side anchor in "L" position. - Push lift cylinder down. - Disconnect electrical system. - Push front pin and back pin release and lock & turn.
INSTALLING PLOW			

PRODUCT SPECIFICATIONS

REQUIRED TOOLS

ISARMATIC® SYSTEM SPECIFICATIONS

⚠ CAUTION
Do not mix different types of hydraulic fluid. Some fluids are not compatible and may cause performance problems and product damage.

Hydraulic System

Hydraulic Oil

- WESTERN® High Performance Fluid to -25°F (-32°C)
- Automatic Transmission Fluid (ATF) Dexron III to -10°F (-23°C) or,
- Texaco 1537 Aircraft Hydraulic Oil for temperatures below -25° F (-32°C).

Hydraulic System

Plow Type	Crossover Relief Valve Pressure (± 100 PSI)	No. of Turns Crossover Relief Valve Is Backed Off (CCW) From Fully Seated*	Pump Relief Valve Pressure (± 100 PSI)	Max. Motor Amp Draw At Relief Pressure**
Standard, Pro	3500	1-1/2 – 2	1750	200
Heavyweight	3500	1-1/2 – 2	1900	210
Sport Utility	2500	2-1/4 – 2-3/4	1550	180

*Settings are approximate.

** Actual readings may vary due to vehicle battery voltage and oil temperature.

Fluid Capacity – Hydraulic Oil

- Unit Reservoir = 1 3/4 Quarts
- System Total:
 - w/ 6" Ram = 2 1/8 Quart Sport Utility
 - w/ 10" Ram = 2 3/8 Quarts Standard & Pro
 - w/ 16" Ram = 2 3/4 Quarts Heavyweight

Solenoid Valve Spool Travel = 0.07" for three- and four-way valves (S2, S3)

Electrical System – approximate values:

- Solenoid Valve Coil Resistance = 6.7 Ohms at room temperature
- Solenoid Valve Coil Amp. Draw = 1.5 Amp.

- Motor Relay Coil Resistance = 16 - 17 Ohms
- Motor Relay Amp. Draw = 0.7 Amp.
- Headlamp Relay Coil Resistance = 106 Ohms
- Headlamp Relay Amp Draw = 0.1 Amp.

Fuse Size

- Harness – 6 Amp. (SFE-6)

Tools Required for servicing the electrical and hydraulic systems:

- Long/Slender Needle Nose Pliers
- Flat Screwdriver
- Sockets and Combination Wrenches: 3/8" thru 7/8", 1-1/16", 1-1/8"
- Deep Socket: 7/8"

- 1/4" Socket or Nut Driver
- 12 V Test Light
- Torque Wrench (in-lb)
- Allen Wrench Set
- 3000 PSI Pressure Gauge w/adaptor fittings

- Flashlight
- Pick Set

- Hammer
- Digital Volt/Ohm Meter
- Pencil Magnet

Available from your WESTERN® outlet:

- UniMount® Electrical Tester

Mechanical

Fastener Torque (in-lb)	
Pump Mounting Cap Screws.....	175 – 185
Motor Terminal Nuts.....	50 – 60
Motor Base Cap Screws	180 – 240
Motor End Cap Screws	35 – 45
Valve Manifold Cap Screws	55 – 60
Solenoid Cartridge Valve	115 – 125
Coil Nut	48 – 60
Cartridge/Coil Cover Screws.....	15 – 20
Base Lug Cap Screws.....	180 – 240
O-Ring Boss Plug.....	50 – 70

ISARMATIC® HYDRAULIC HOSE ROUTING AND FITTING ORIENTATION

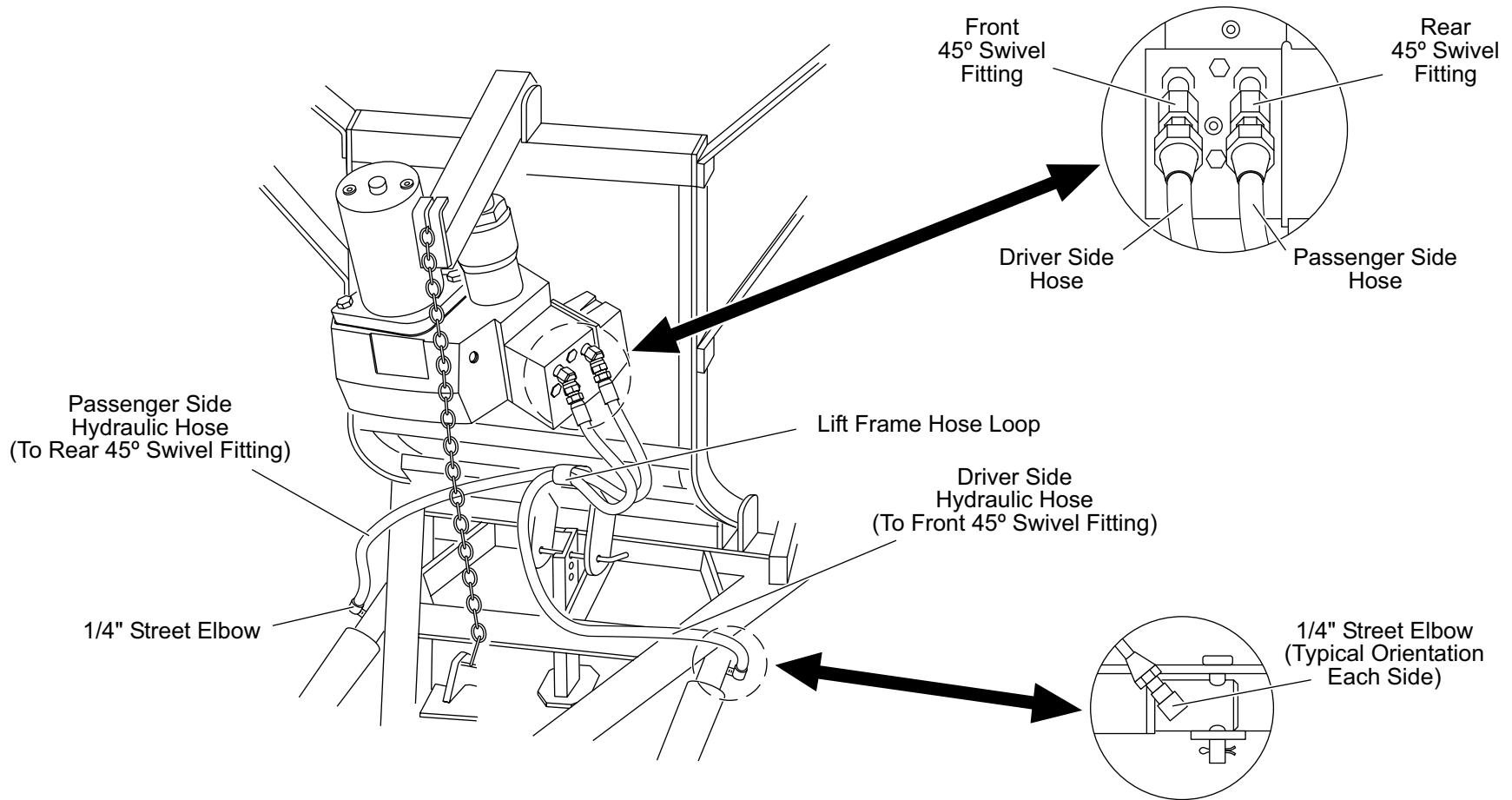

ISARMATIC® HYDRAULIC UNIT PARTS DIAGRAM

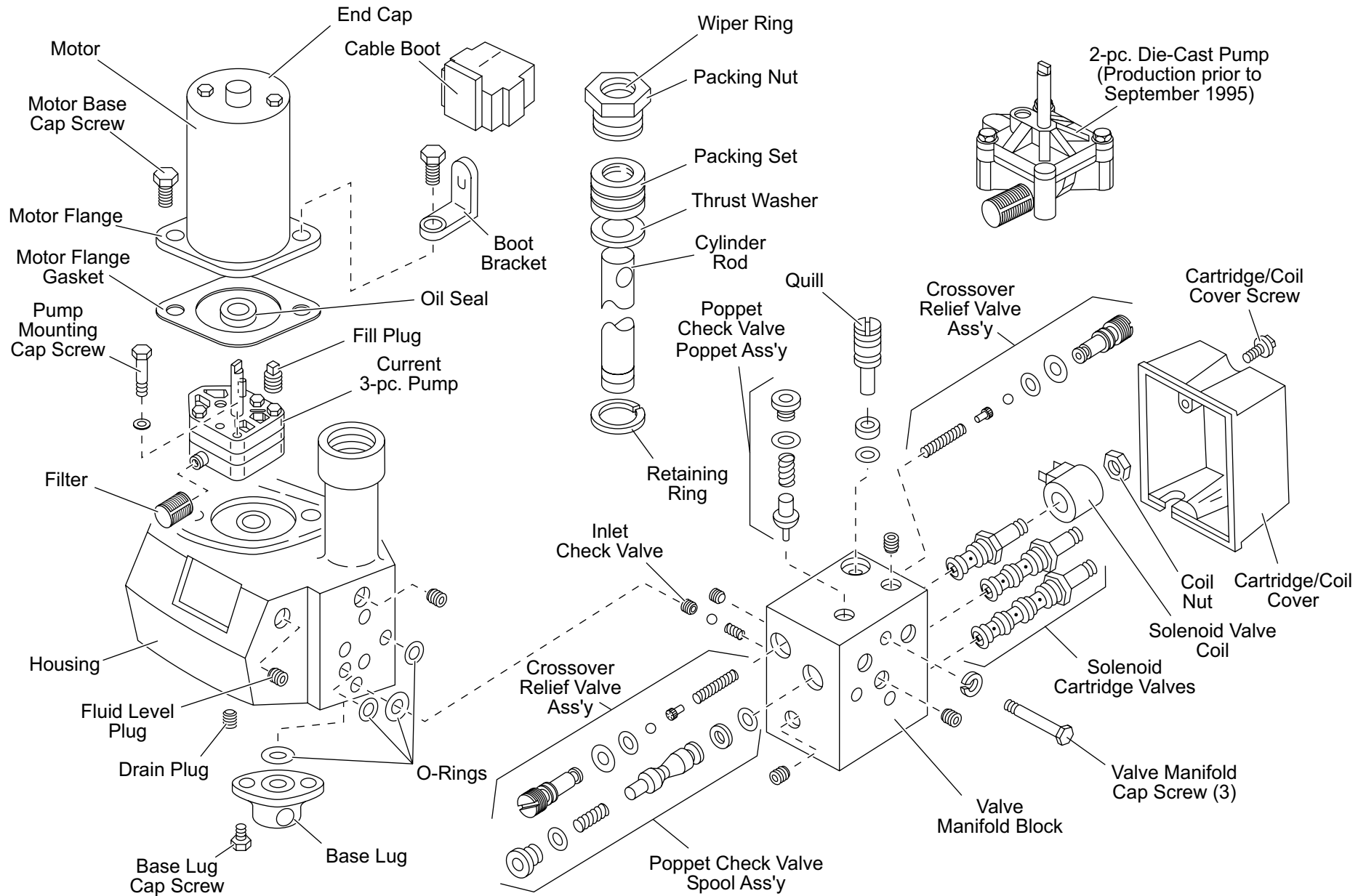

ISARMATIC® HYDRAULIC UNIT VALVE IDENTIFICATION AND LOCATION

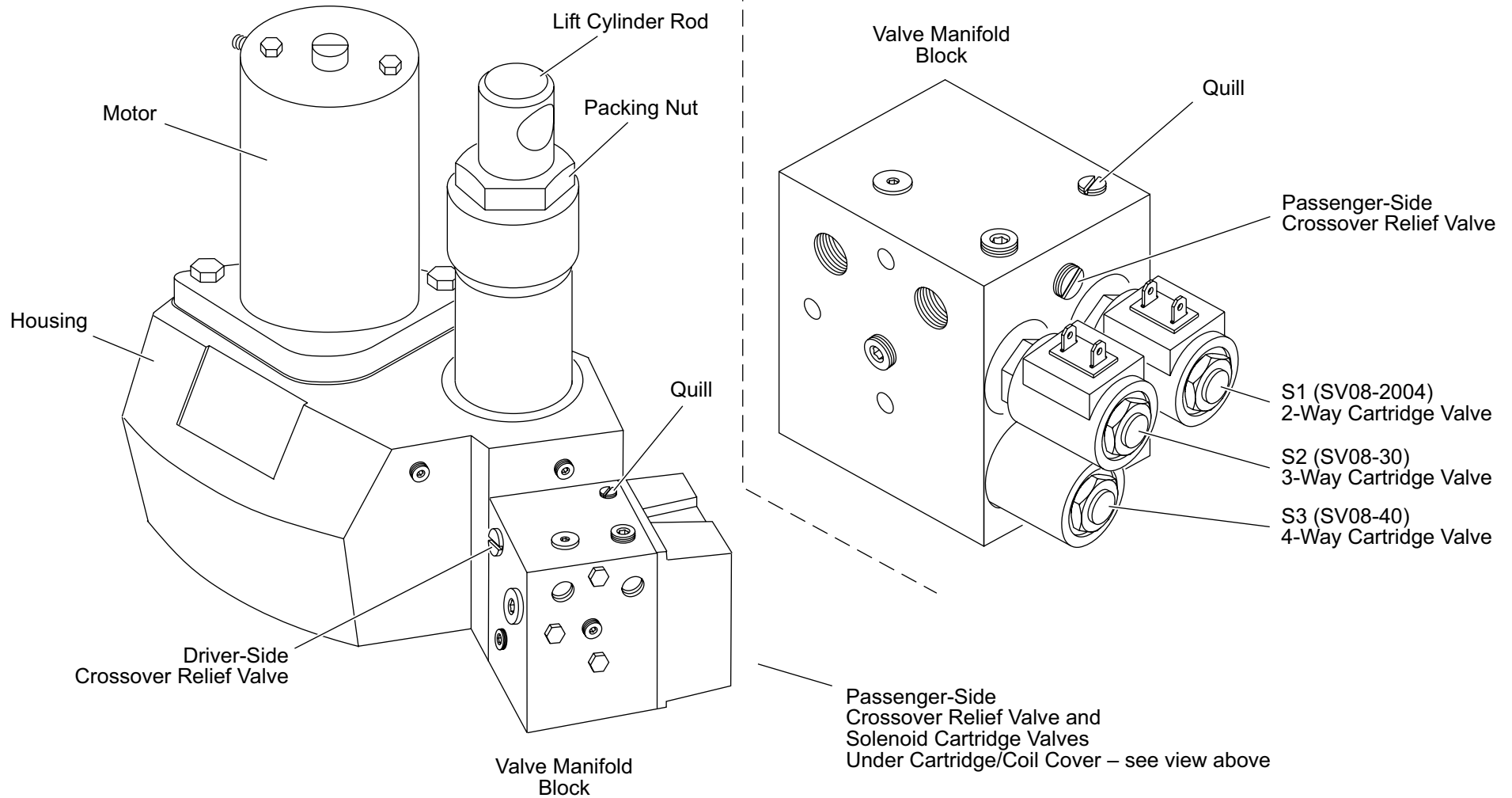

VEHICLE HARNESS AND VEHICLE CABLE LOCATION

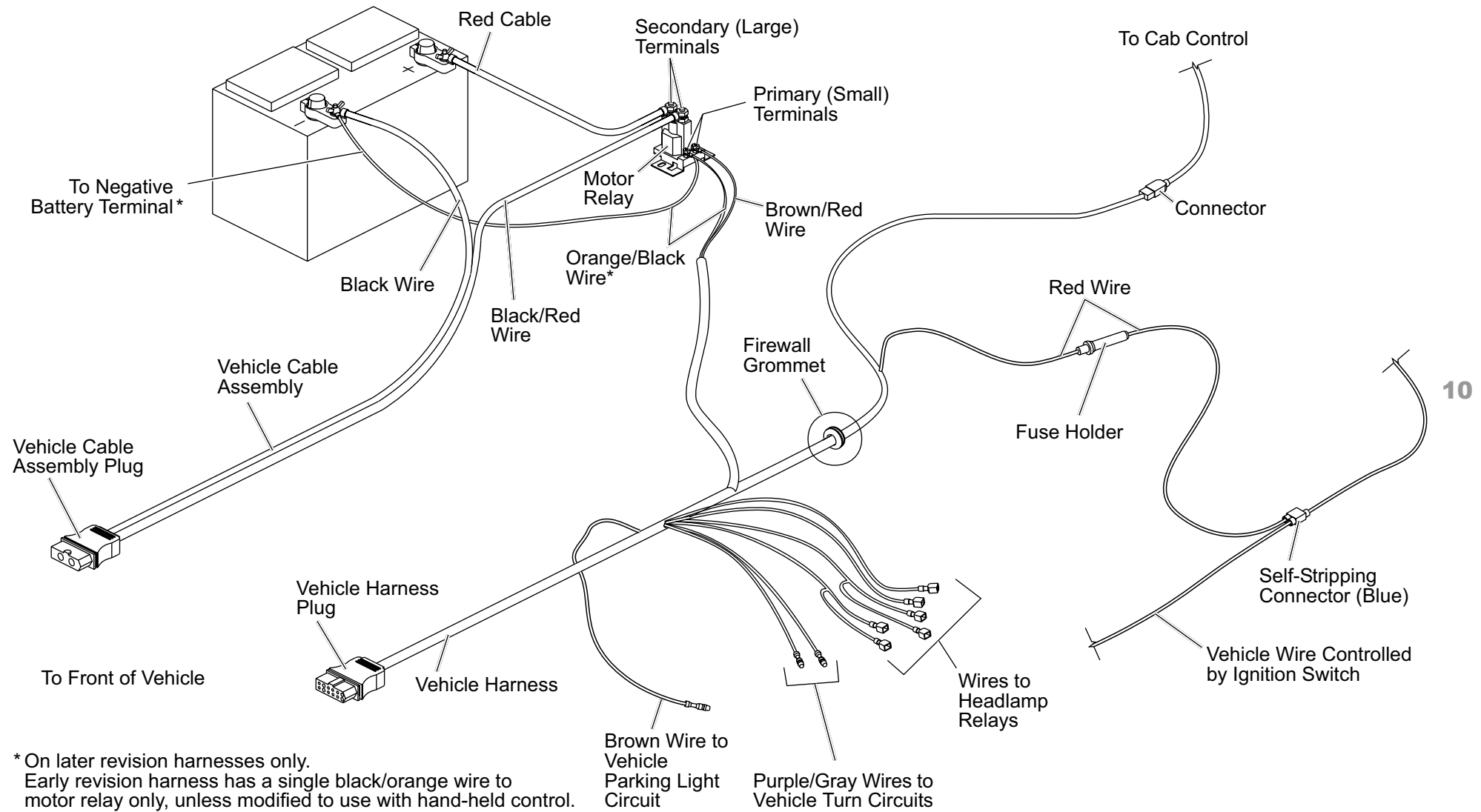

OPERATING THE SNOWPLOW

SOLENOID CONTROL

⚠ WARNING

The driver shall keep bystanders clear of the blade when it is being raised, lowered or angled. Do not stand between the vehicle and the blade, or within 8 feet of a moving blade. A moving or falling blade could cause personal injury.

⚠ CAUTION

To prevent accidental movement of the blade, always turn the ON/OFF switch to OFF whenever the snowplow is not in use. The control indicator light will turn off.

Turn the vehicle ignition switch to the ON or the ACCESSORY position. Move control ON/OFF switch to the ON position. The control indicator light (red) should light whenever the control ON/OFF switch and the ignition (key) are both turned ON.

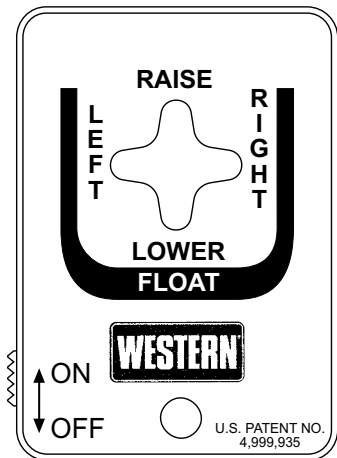

Turn the vehicle ignition switch on. Turn the control on. The control indicator light should be on.	
Action	Description of Operation
ON/OFF	Slide the control power switch ON to activate the hydraulic system. Turn the control OFF to lock the blade in place. This will prevent accidental movement of the blade.
Right	Move the control lever right to angle the blade to the right.
Left	Move the control lever left to angle the blade to the left.
Raise	Move the control lever up (forward) to raise the blade to the desired height.
Lower/Float	Move the control lever down (back) to lower the blade and activate the FLOAT mode.
To Cancel FLOAT	The FLOAT mode can be canceled by either momentarily placing the control in the RAISE position, turning the control off or turning the vehicle ignition off. Angling left or right will not cancel float.

OPERATING THE SNOWPLOW

CABCOMMAND HAND-HELD CONTROL

⚠ WARNING

The driver shall keep bystanders clear of the blade when it is being raised, lowered or angled. Do not stand between the vehicle and the blade, or within 8 feet of a moving blade. A moving or falling blade could cause personal injury.

⚠ CAUTION

To prevent accidental movement of the blade, always turn the ON/OFF switch to OFF whenever the snowplow is not in use. The control indicator light will turn off.

1. Turn the vehicle ignition switch to the ON or the ACCESSORY position. The controller logo area will become illuminated.*
2. Press the ON/OFF button on the control. The control indicator light will glow red indicating the control is on. The control indicator light

will glow red whenever the control ON/OFF switch and the vehicle ignition switch are both ON.

3. Pressing the LOWER button for 0.75 seconds will engage the FLOAT mode. The control indicator FLOAT light will glow green.* Cancel the FLOAT mode by momentarily pressing the RAISE button.

The time-out period for the RAISE function is 2.4 seconds, while the angle function is 4.8 seconds.

The control will automatically turn off after being idle for 20 minutes.

Smooth Stop

The control automatically allows the blade to coast to a stop. This results in smoother operation, reduces the shock to the hydraulic system and increases hose and valve life.

Function Time Outs

All control functions, except for LOWER, automatically time out – stop – after a period of time. This is to prevent unnecessary battery drain.

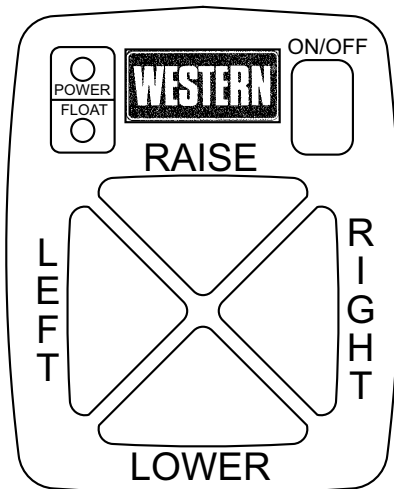

Button	Description of Operation
Right	Press this button to angle blade to the right.
Left	Press this button to angle blade to the left.
Raise	Press this button to raise the plow and to cancel the float mode. NOTE: Plow will automatically stop raising after 2.4 seconds.
Lower/ Float	Press this button to lower the plow. NOTE: After reaching the desired height, release the button. Holding the button down for more than 3/4 second will activate the float mode, indicated by green FLOAT light.*
Cancel Float	The float mode can be cancelled by pressing the RAISE button, turning control off or turning vehicle ignition off. Angling left or right will momentarily cancel float.

*Early models do not have FLOAT light or illuminated logo.

THEORY OF OPERATION

SNOWPLOW HEADLAMPS

The type of headlamp circuit varies, depending on the make/model/year of vehicle and whether or not it is equipped with Daytime Running Lights (DRLs). The headlamp switching circuit uses two or more relays. When combined with the plug-in headlamp harness, plow light harness and vehicle harness, the relays automatically switch between vehicle and snowplow headlamps as the harness plugs are connected and disconnected.

Vehicles with Daytime Running Lights (DRLs) require a DRL kit which is an additional fused pink wire used in place of the brown wire.

SNOWPLOW PARK/TURN LAMPS

In an ordinary installation, the snowplow Park/Turn lamps are wired in parallel with the corresponding vehicle circuits. Some installations

on trucks with clearance lights require an optional Park/Turn Relay Kit which allows the snowplow park lamps to operate directly off the battery, using the vehicle circuit to power only the relay. In either case, the vehicle and snowplow park and turn lamps will operate simultaneously.

NOTE: The headlamp wiring schematics and electrical information included in this manual are typical for most 1998 and older vehicles. For 1999 and newer vehicles, refer to the snowplow installation instructions.

SNOWPLOW HYDRAULICS

The snowplow hydraulic system performs four blade movement functions. All functions require the vehicle ignition (key) switch to be in the run position and the cab control to be turned on.

The cab control supplies power to the motor relay and the three solenoid cartridge valves in various combinations to direct hydraulic fluid to the snowplow lift and angle cylinders or back to the reservoir.

Raise and angle functions require both the motor and solenoid cartridge valve(s) to activate, while the lower function only requires activation of a solenoid cartridge valve. The motor and valves are deactivated when the cab control button or lever is released. The high amperage motor power circuit is completed through the battery cables when the motor relay is activated. The motor relay and solenoid cartridge valve circuits are low amperage, high side drive, and are completed when the cab control is activated.

Proper operation of the snowplow hydraulic system depends on the vehicle's ability to provide adequate electrical power. Electrical loads from

the snowplow, vehicle and accessories can substantially reduce the vehicle system voltage if the charging system cannot meet the electrical demand. A low voltage condition can cause intermittent snowplow operation because the magnetic field produced in the solenoid cartridge valve coils may not be strong enough to shift the valves. Because of many variables, it is impossible to determine the point at which the system voltage is too low to consistently operate the snowplow. This condition can be difficult to diagnose because the coil magnetism can still be detected and no problem exists in the hydraulic system. Do not overlook the fact that an apparent problem with the snowplow can actually be caused by low voltage in the vehicle electrical system. Consult a vehicle repair manual for electrical system specifications.

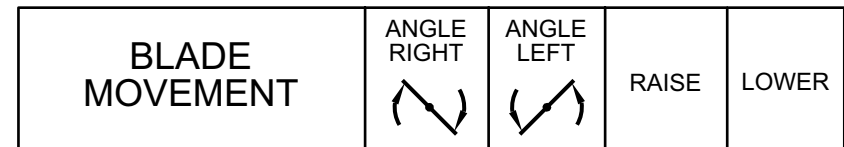

HYDRAULIC AND ELECTRICAL SCHEMATICS













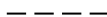



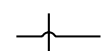





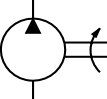

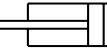

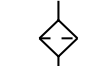
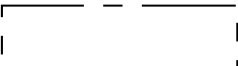
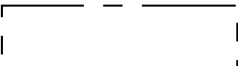
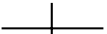

The following section contains hydraulic and electrical schematics to help explain how the hydraulic unit performs the different functions. A schematic is an abstract drawing showing the purpose of each of the components in the system. Each component is represented by a graphical symbol. The hydraulic and electrical legends list and describe each of the symbols used in the schematics for this guide.

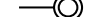
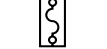
The first two schematics show a general overview of the complete hydraulic and electrical systems. The remainder of the schematics have been altered to highlight flow of hydraulic oil and electrical current for each function the hydraulic unit performs or flow of electrical current for the snowplow and vehicle lights.

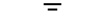
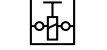
- Bold lines represent the circuit being activated only.
- Shaded components are either activated or shifted from their normal position.

NOTE:

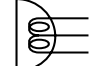
Left side = Driver side
Right side = Passenger side

HYDRAULIC LEGEND		ELECTRICAL LEGEND	
	LINE, WORKING (MAIN)		SPRING
	LINE, PILOT (FOR CONTROL)		SOLENOID, SINGLE WINDING
	LINES JOINING		PILOT OPERATED (P/O) CHECK VALVE
	LINES CROSSING		VALVE, ADJUSTABLE PRESSURE RELIEF
	FLOW, DIRECTION OF HYDRAULIC FLUID		VALVE, FLOW CONTROL, ADJUSTABLE-NON-COMPENSATED
	LINE, TO RESERVOIR BELOW FLUID LEVEL		VALVE, TWO POSITION TWO CONNECTION (TWO-WAY) S1
	HYDRAULIC PUMP FIXED DISPLACEMENT		VALVE, TWO POSITION THREE CONNECTION (THREE-WAY) S2
	CYLINDER		VALVE, TWO POSITION FOUR CONNECTION (FOUR-WAY) S3
	ELECTRIC MOTOR		CHECK VALVE
	FILTER, STRAINER DIFFUSER		COMPONENT ENCLOSURE
	COMPONENT ENCLOSURE		CROSSING WIRE
			WIRE SPLICE
			IN LINE CONNECTOR
			RING TERMINAL
			FUSE
			SOLENOID
			DIODE
			CIRCUIT GROUND
			MOTOR RELAY
			BATTERY
			MOTOR
			PARK/TURN LAMP
			HEADLAMP
			COMPONENT ENCLOSURE

Wire Color Code						Abbreviations			
BLK	Black	BRN/GRN	Brown w/ Green	LTBLU	Light Blue	PUR	Purple	DRL	Daytime Running Lights
BLK/ORN	Black w/ Orange	BRN/RED	Brown w/ Red	LTGRN	Light Green	RED	Red	MTR RLY	Motor Relay
BLK/RED	Black w/ Red	DKBLU	Dark Blue	LTBLU/ORN	Light Blue w/ Orange	TAN	Tan	P/T SIG	Park/Turn Signal
BLK/WHT	Black w/ White	DKBLU/ORN	Dark Blue w/ Orange	LTBLU/WHT	Light Blue w/ White	VIO	Violet		
BLU	Blue	DKBLU/WHT	Dark Blue w/ White	ORN	Orange	WHT	White		
BLU/ORN	Blue w/ Orange	GRN	Green	ORN/BLK	Orange w/ Black	WHT/YEL	White w/ Yellow		
BRN	Brown	GRY	Gray	PNK	Pink	YEL	Yellow		

ELECTRICAL SCHEMATIC – 9-PIN HARNESS ('98 AND OLDER VEHICLES)

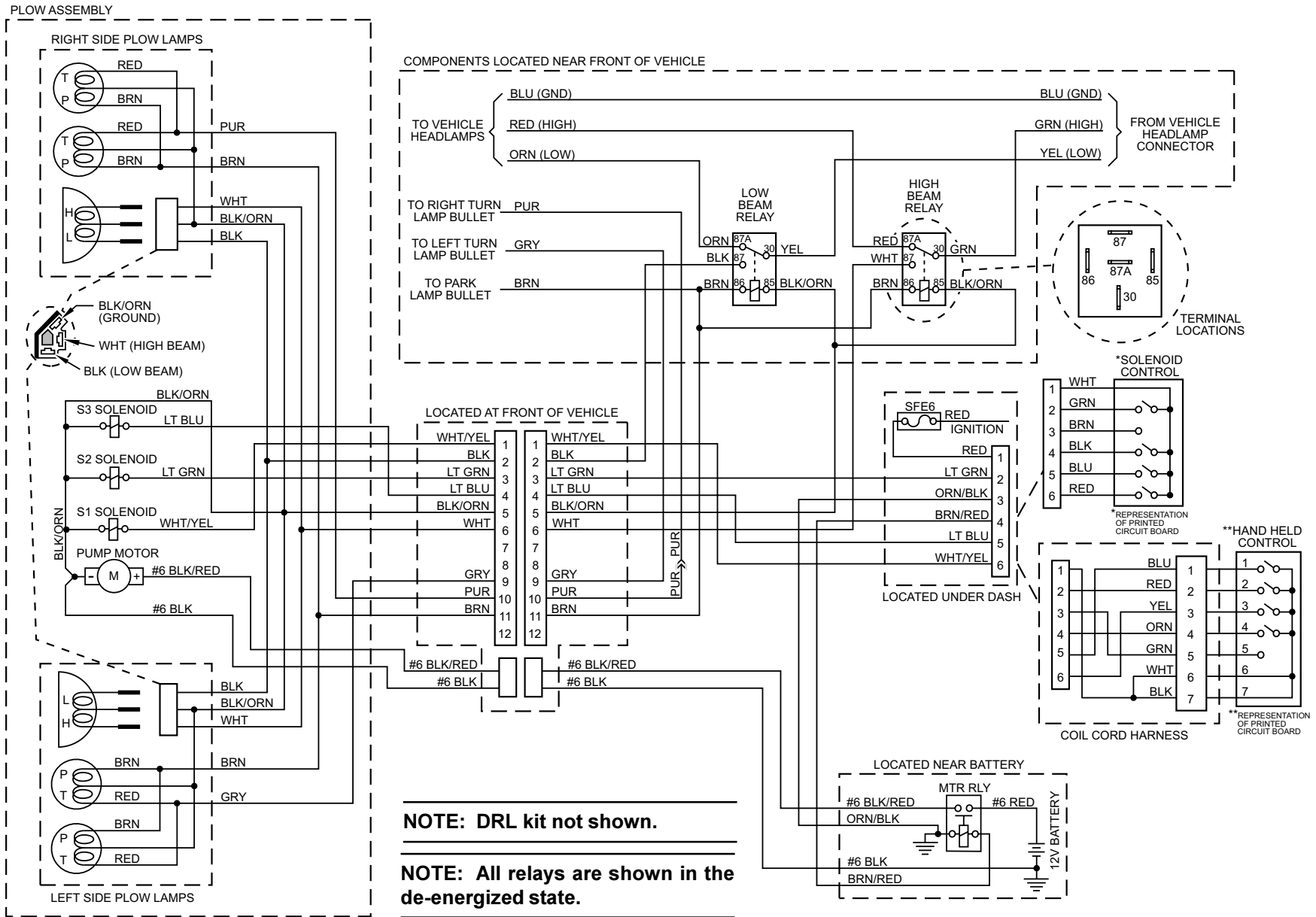

ELECTRICAL SCHEMATIC – 12-PIN HARNESS ('98 AND OLDER VEHICLES)

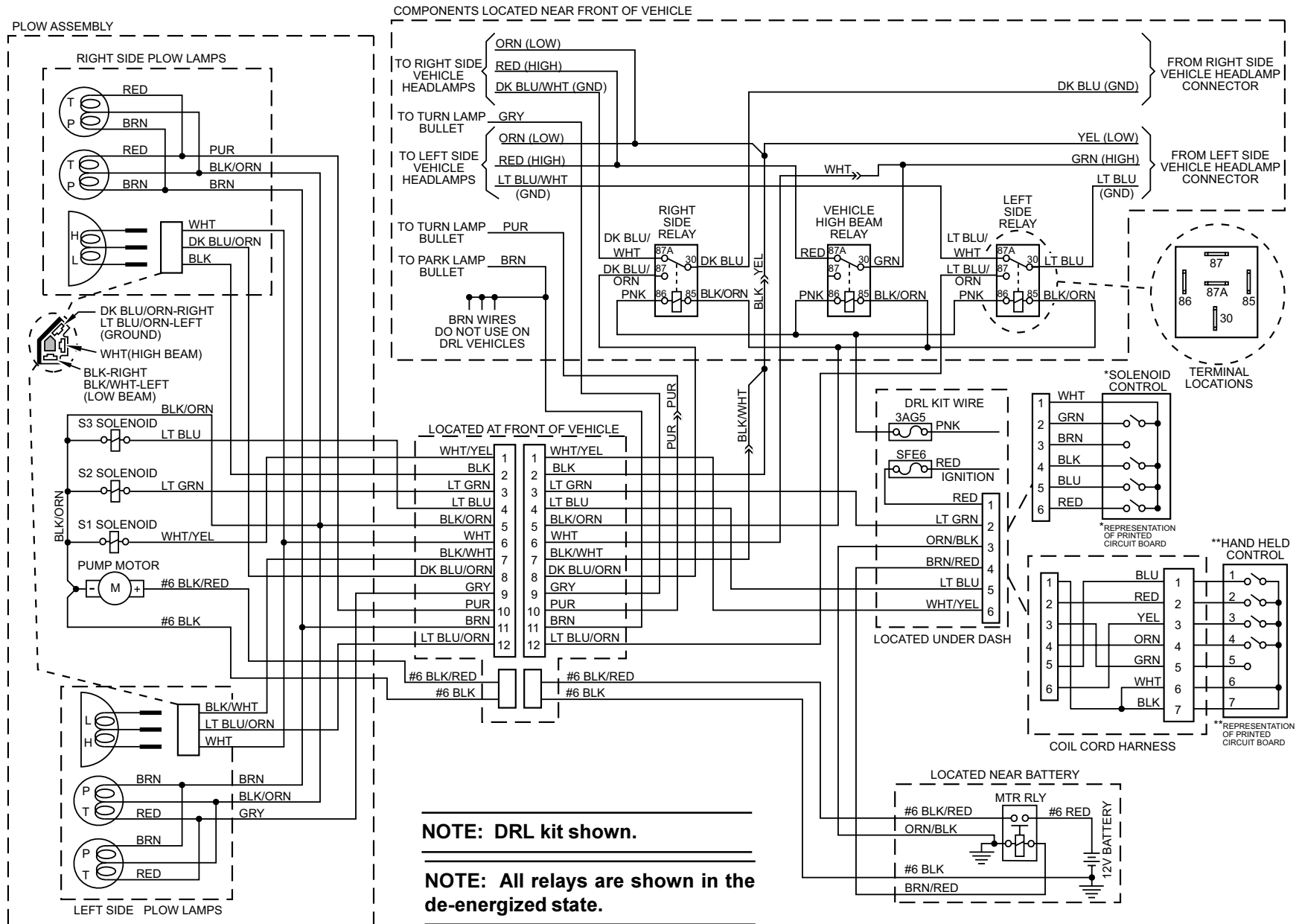

HYDRAULIC SCHEMATIC

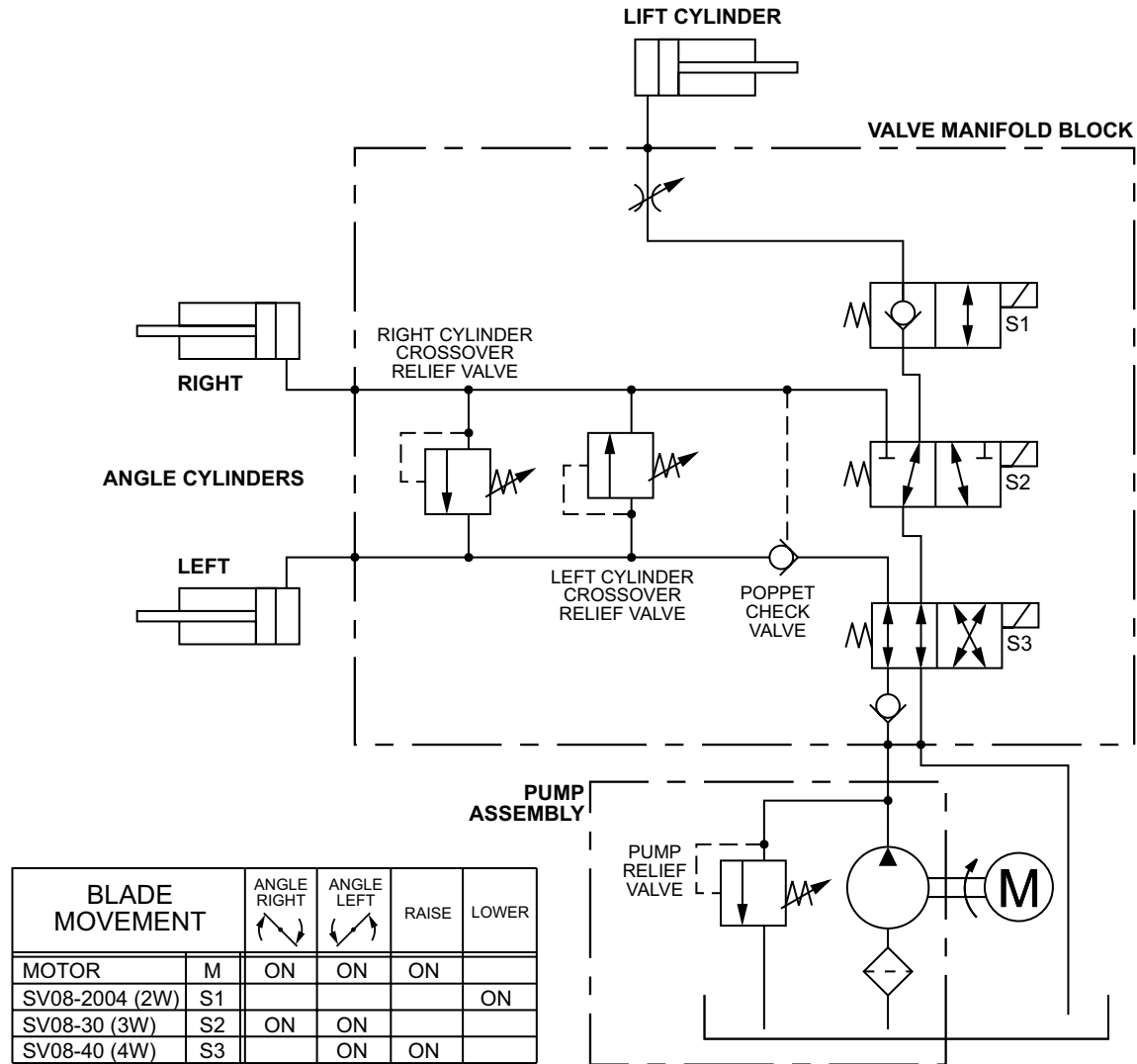

ANGLE RIGHT – ELECTRICAL

Blade Movement: Angle Right

Controller: Right

System Response:

- 1) By moving control lever or pressing the controller button, the circuit board within the cab control

supplies power for the electrical circuit.

- 2) Electrical current flows through the motor relay, activating the pump motor, and solenoid cartridge valve S2, shifting its spool.

- 3) Hydraulic oil from the pump flows through the inlet check valve, solenoid cartridge valve S3 and the poppet check valve, and into the base end of the left cylinder, causing it to extend.

- 4) The retracting right cylinder pushes the hydraulic oil out of its base end, through solenoid cartridge valves S2 & S3 back to the reservoir.

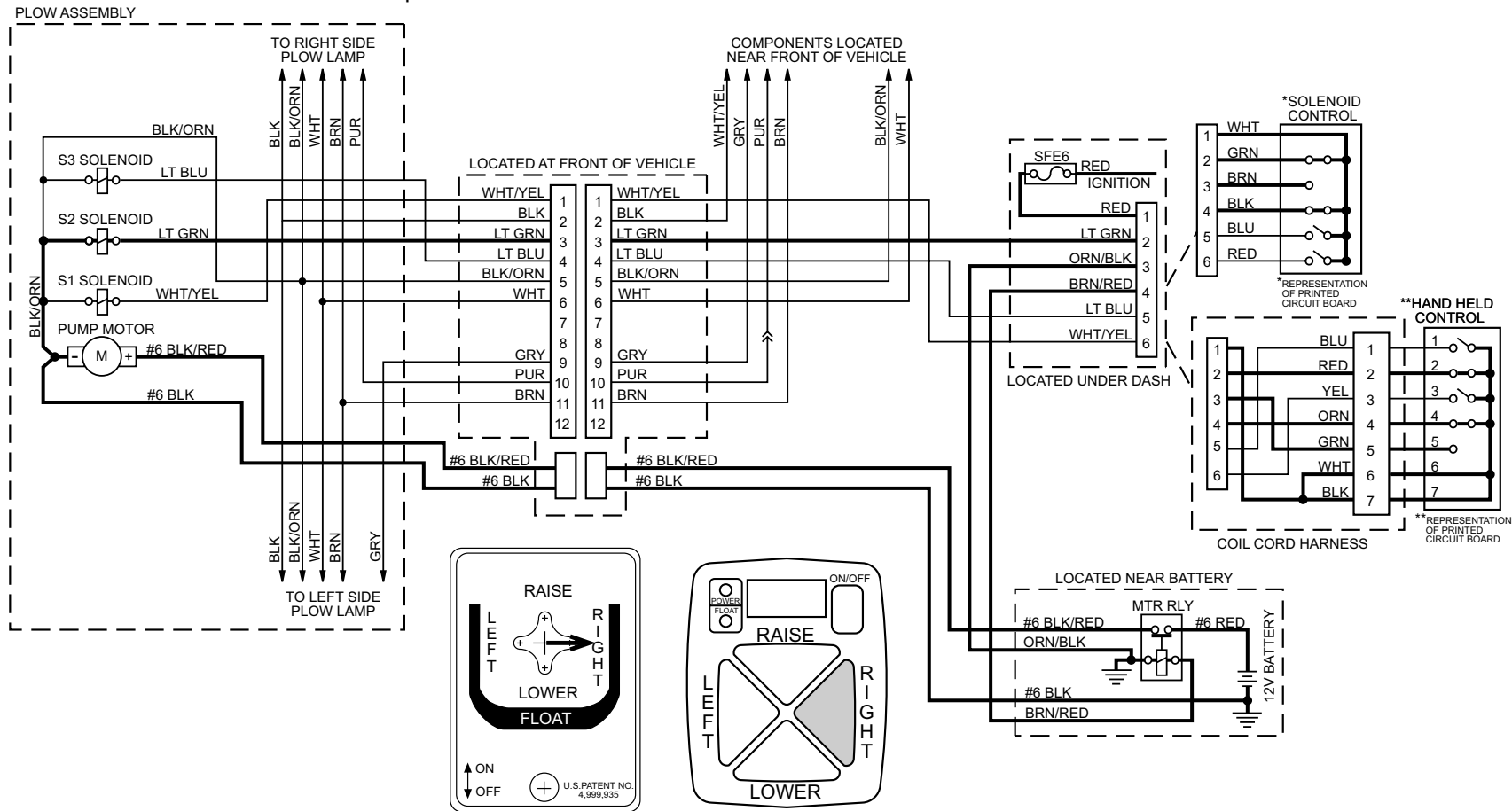

BLADE MOVEMENT
ANGLE RIGHT

ANGLE RIGHT – HYDRAULIC

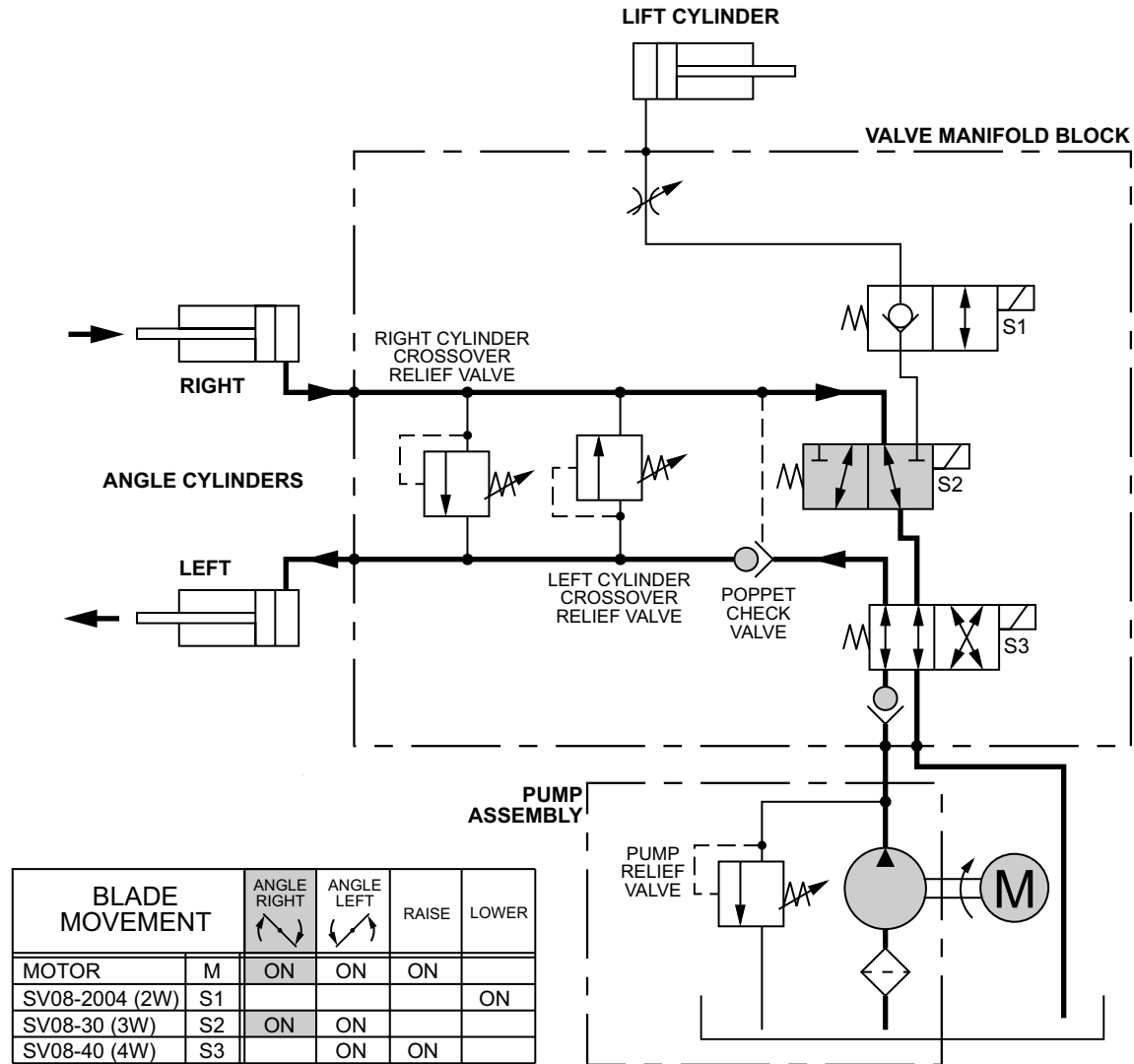

ANGLE LEFT – ELECTRICAL

Blade Movement: Angle Left

Controller: Left

System Response:

- 1) By moving control lever or pressing the controller button, the circuit board within the cab control

supplies power for the electrical circuit.

- 2) Electrical current flows through the motor relay, activating the pump motor, and solenoid cartridge valves S2 & S3, shifting both spools.

- 3) Hydraulic oil from the pump flows through the inlet check valve and solenoid cartridge valves S3 & S2, and into the base end of the right cylinder, causing it to extend.

- 4) Pressure within the hydraulic circuit shifts the spool, opening the poppet check valve.

- 5) The retracting left cylinder pushes the hydraulic oil out of its base end, through the open poppet check valve and solenoid cartridge valve S3 and back to the reservoir.

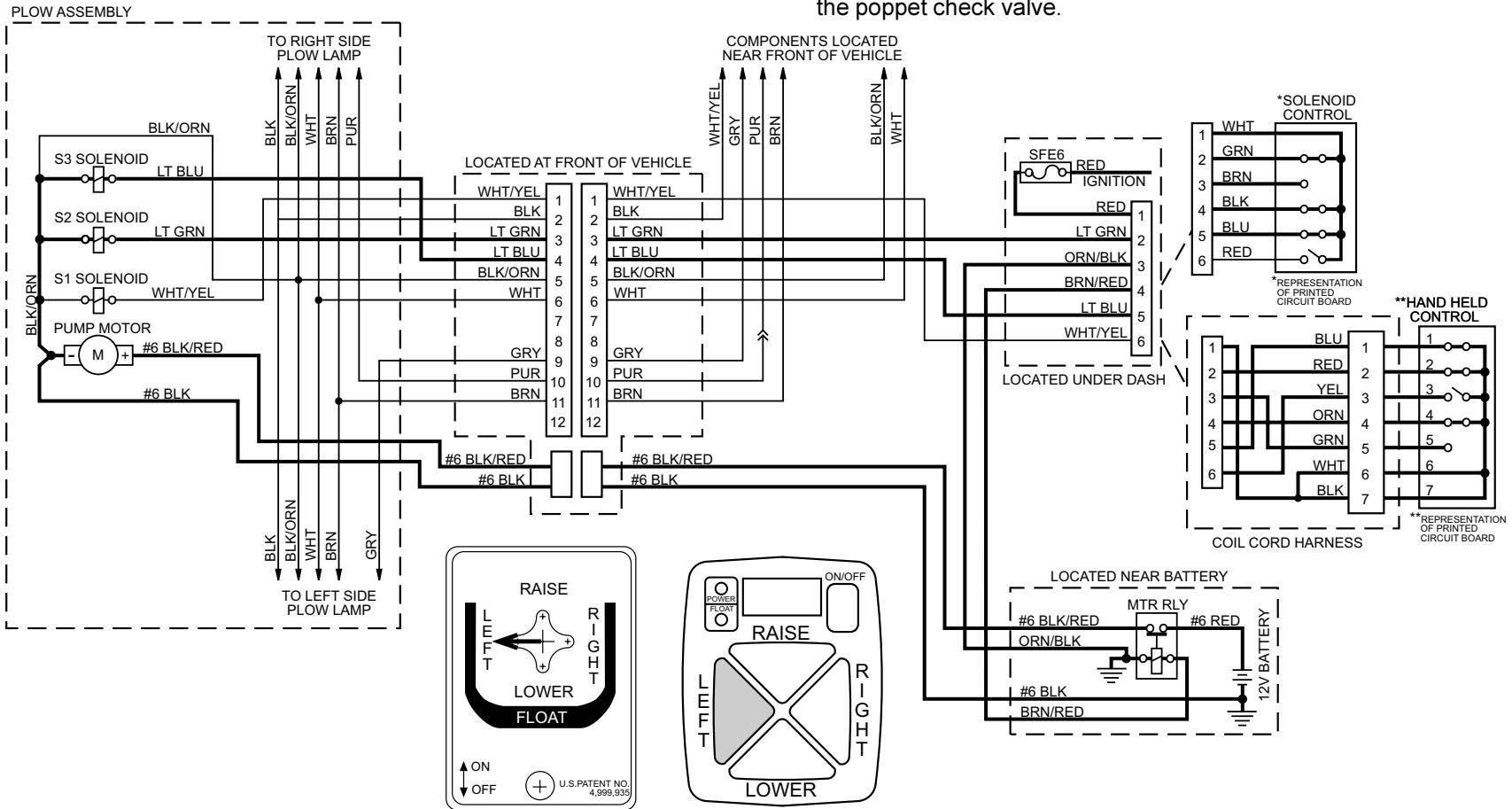

BLADE MOVEMENT
ANGLE LEFT

ANGLE LEFT – HYDRAULIC

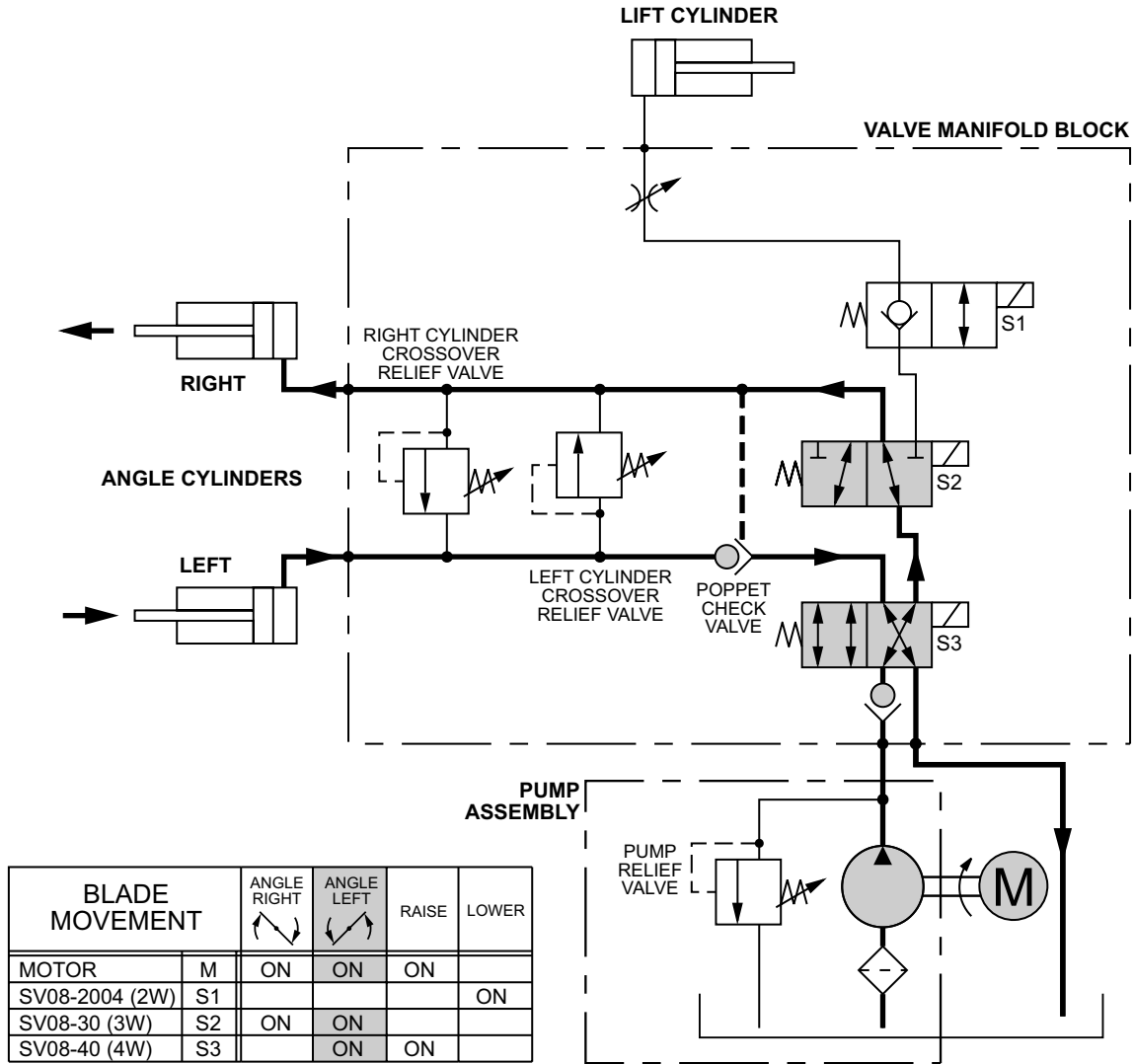

RAISE – ELECTRICAL

Blade Movement: Raise

Controller: Raise

System Response:

- 1) By moving control lever or pressing the controller button, the circuit board within the cab control

supplies power for the electrical circuits.

- 2) Electrical current flows through the motor relay, activating the pump motor, and solenoid cartridge valve S3, shifting the spool.

- 3) Hydraulic oil from the pump flows through the inlet check valve, solenoid cartridge valves S3 & S2 and the internal check valve in solenoid cartridge valve S1, and into the lift cylinder causing it to extend.

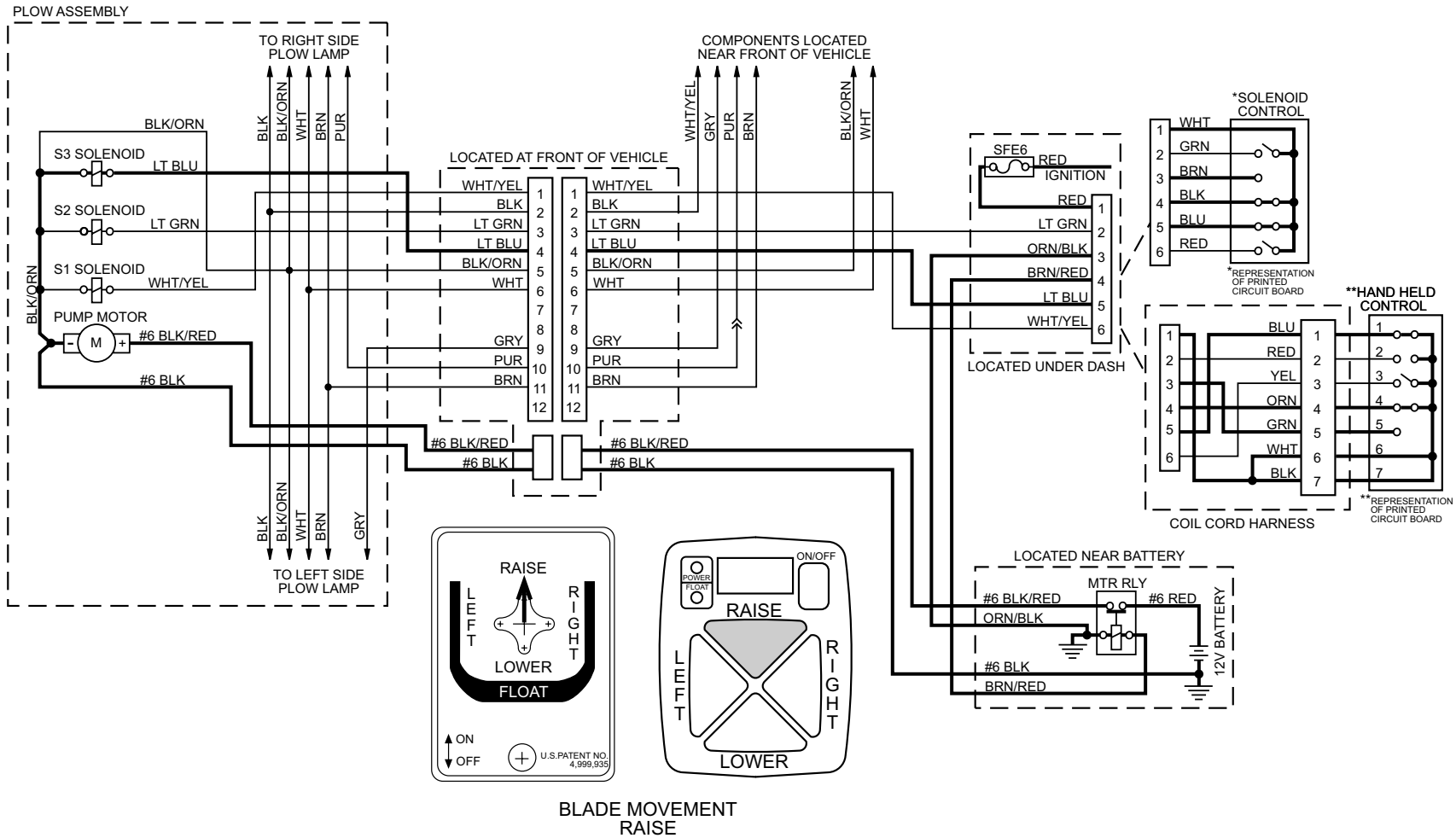

RAISE – HYDRAULIC

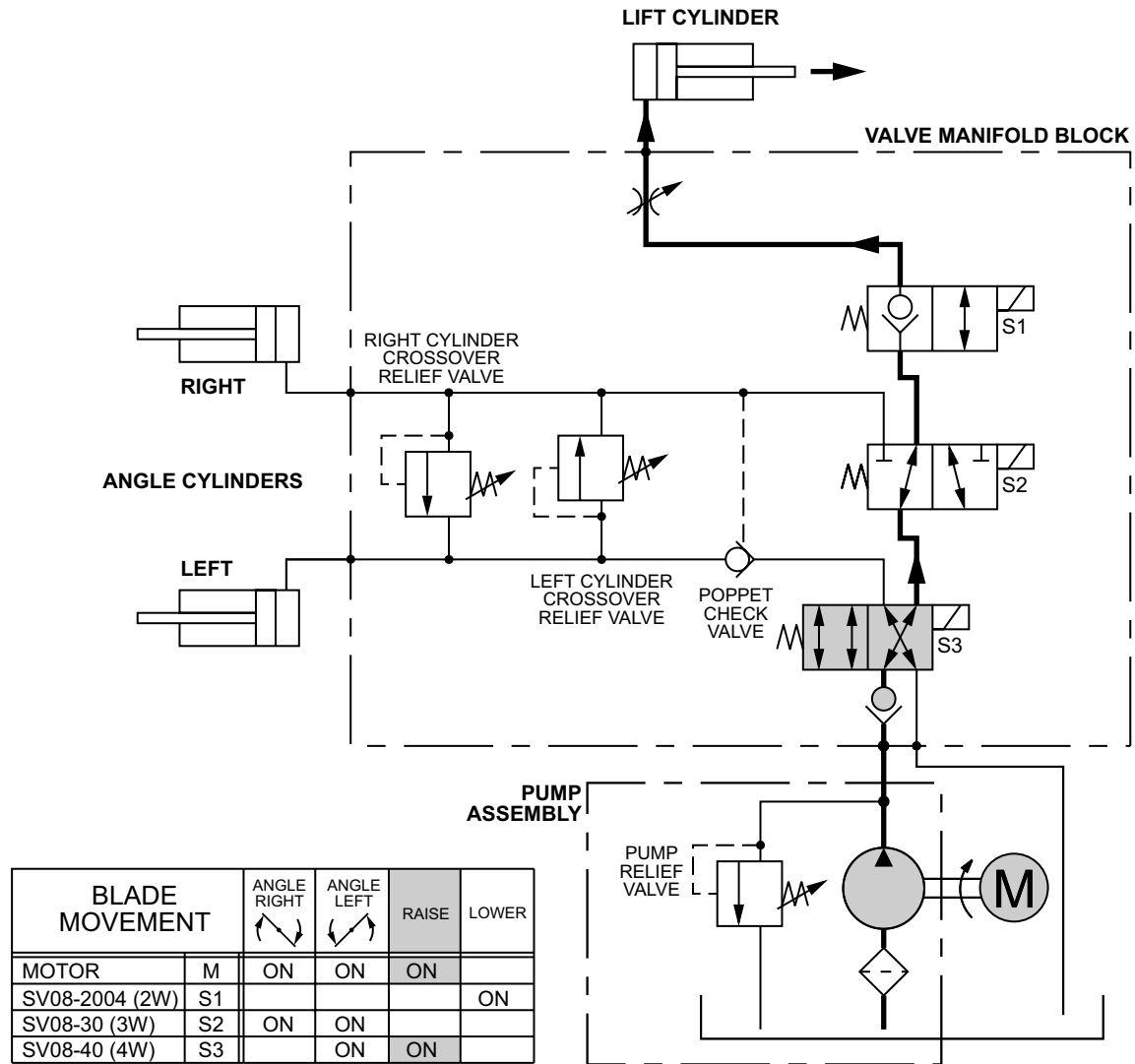

LOWER – ELECTRICAL

Blade Movement: Lower / Float
 Controller: Lower

System Response:

- 1) By moving control lever or pressing the controller button, the circuit board within the cab control

supplies power for the electrical circuit.

- 2) Electrical current flows through solenoid cartridge valve S1, shifting the spool.

- 3) The weight of the plow forces the lift cylinder to retract. The retracting lift cylinder pushes the hydraulic oil through solenoid cartridge valves S1 & S2 & S3, and back to the reservoir.

NOTE: CabCommand hand-held control only – while in FLOAT, angling right or left will temporarily cancel float (turn off solenoid cartridge valve S1) until the angle button is released.

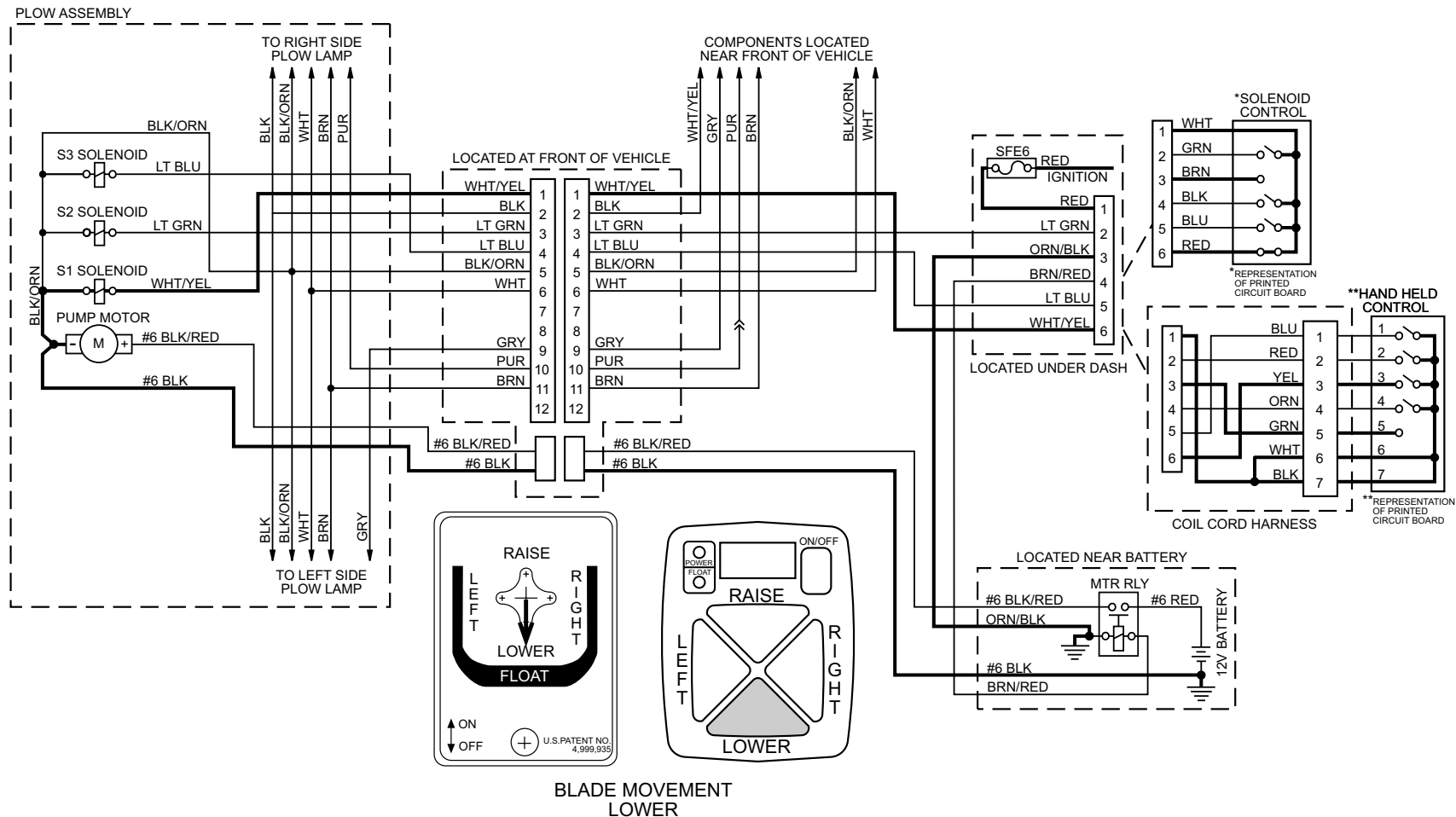

LOWER – HYDRAULIC

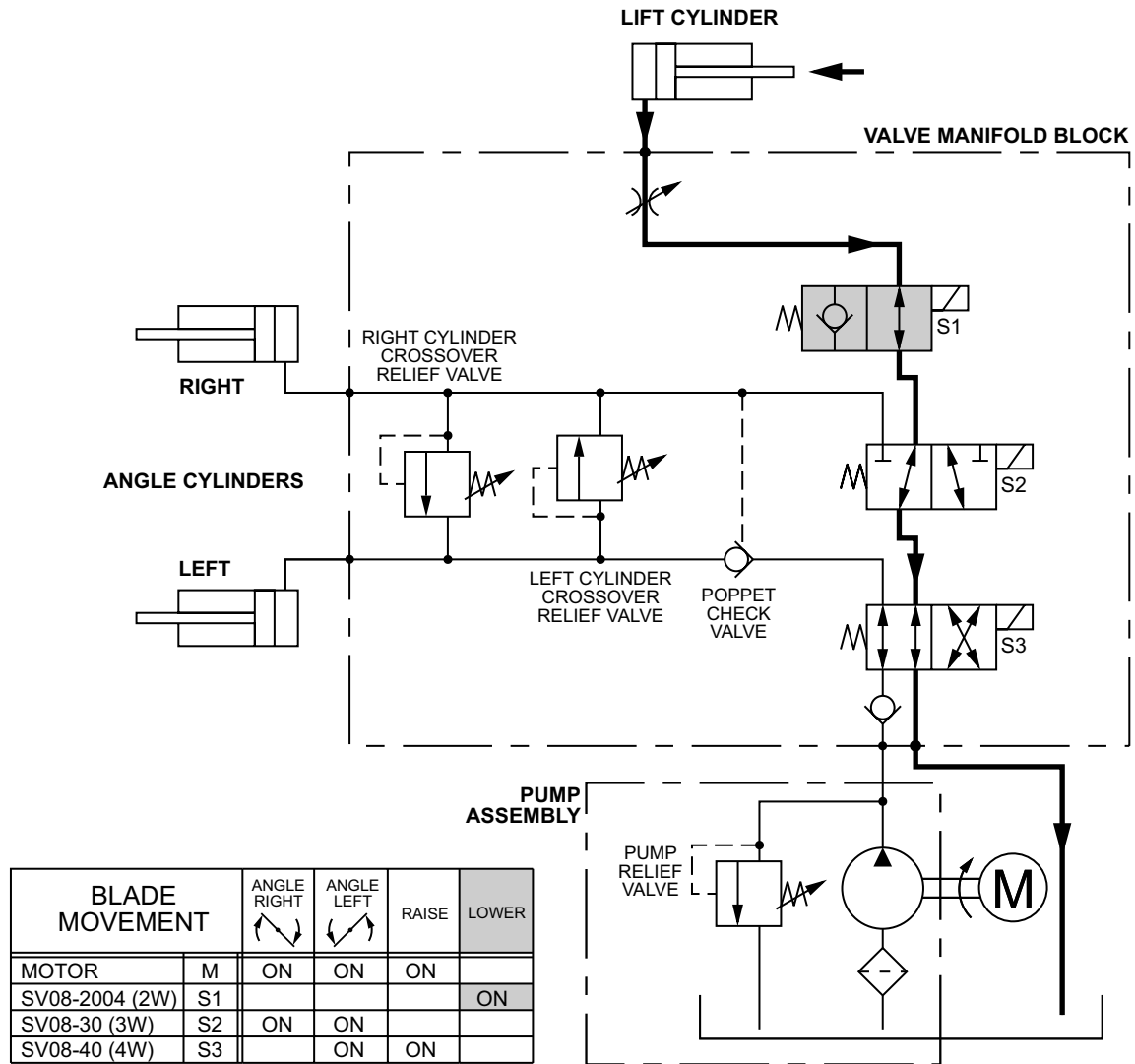

HOLD IN RAISED POSITION – HYDRAULIC

Blade Movement: Hold in Raised Position

Controller: None

System Response:

- 1) Hydraulic oil is trapped in the lift cylinder by the internal check valve in solenoid cartridge valve S1.

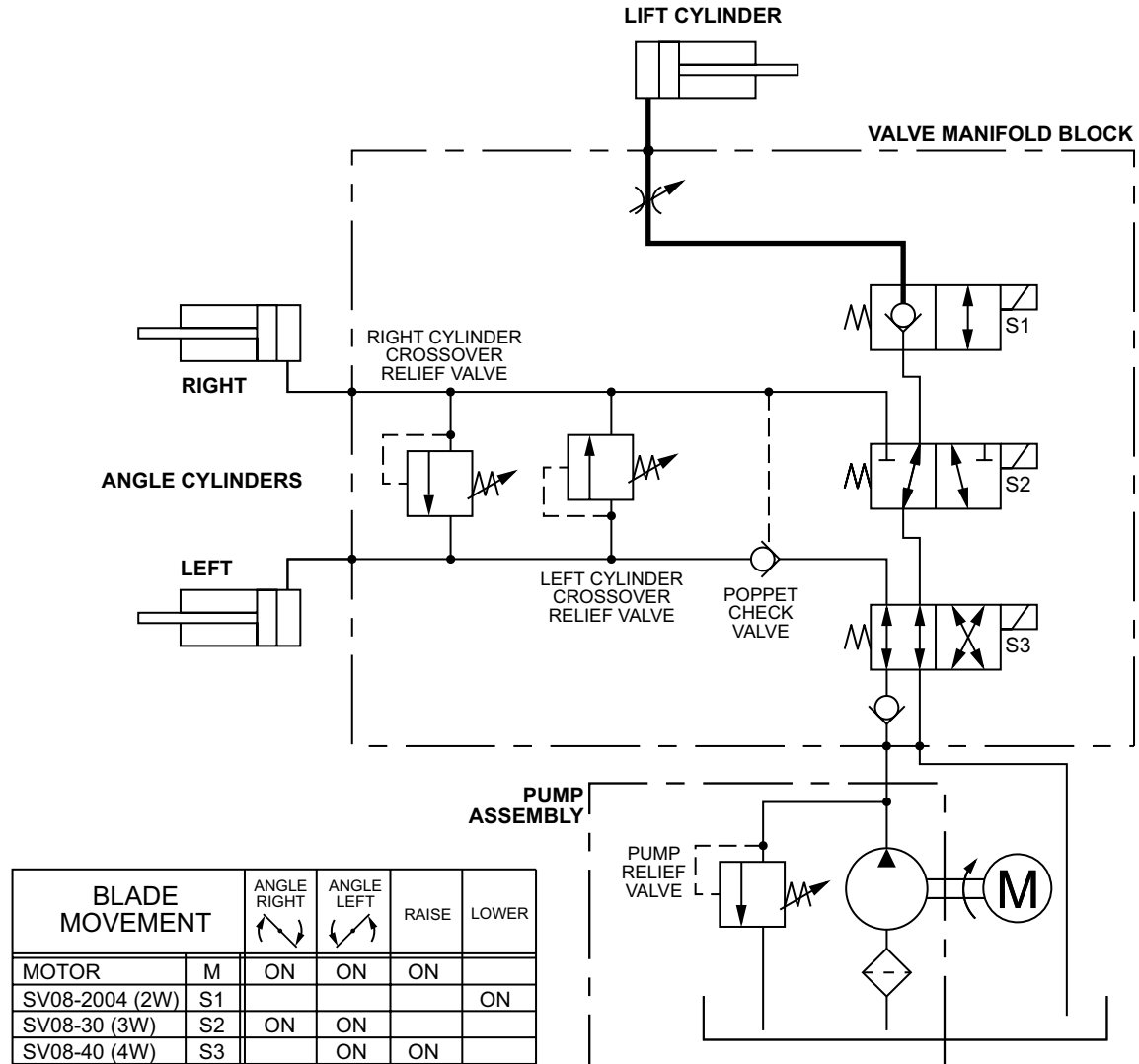

STRIKING AN OBJECT WHILE PLOWING – RIGHT HYDRAULIC CYLINDER RETRACTS

Blade Movement: Striking an Object While Plowing

Controller: None

System Response:

- 1) Hydraulic oil is trapped in the base end of the cylinders by the relief valves, the poppet check valve and solenoid cartridge valve S2.
- 2) When the plow contacts an object, the force of the impact increases the hydraulic pressure in the base end of the cylinder. When the pressure exceeds the relief valve pressure setting, the relief valve opens allowing oil flow to the base of the opposite cylinder.

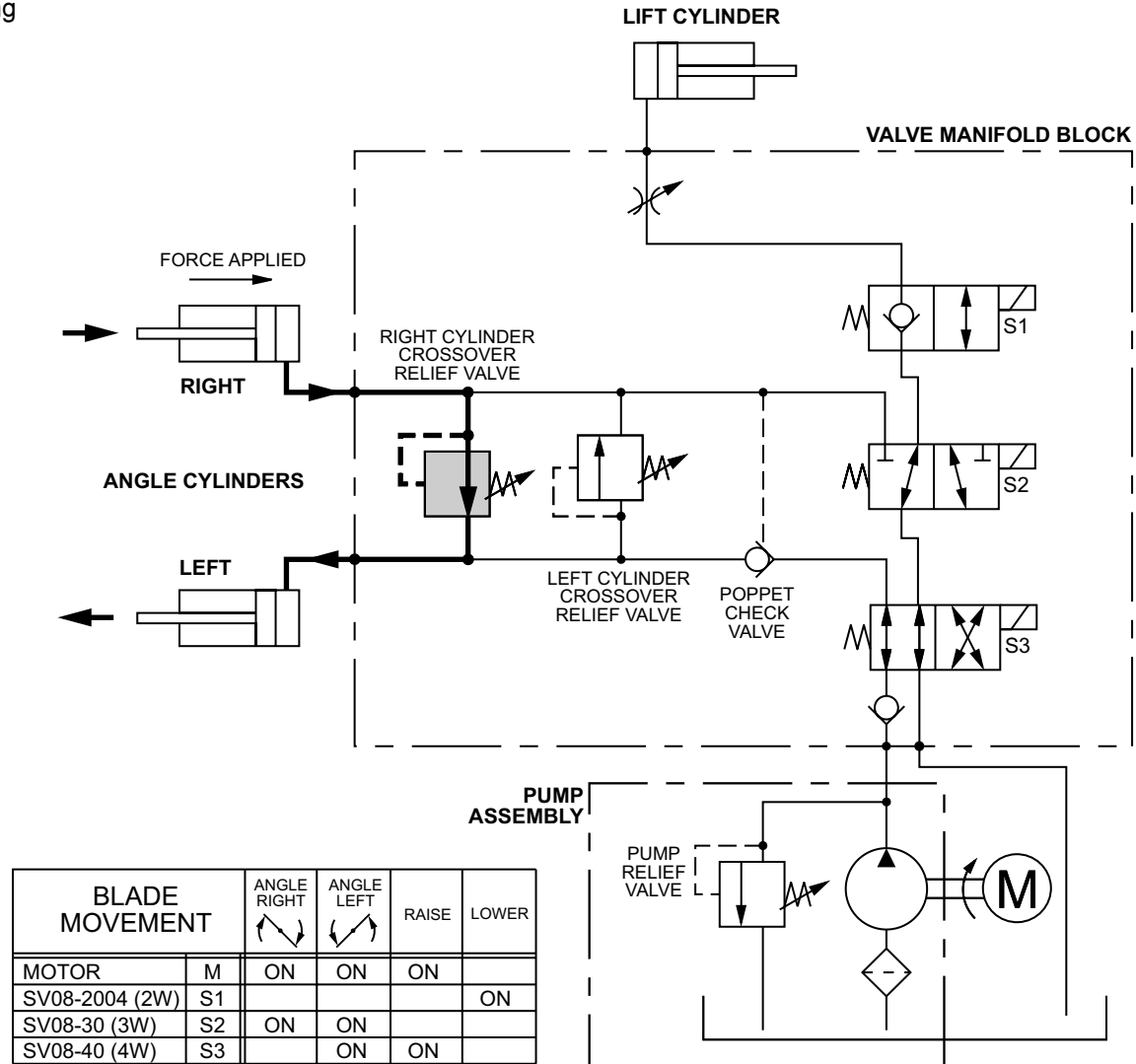

STRIKING AN OBJECT WHILE PLOWING – LEFT HYDRAULIC CYLINDER RETRACTS

Blade Movement: Striking an Object While Plowing

Controller: None

System Response:

- 1) Hydraulic oil is trapped in the base end of the cylinders by the relief valves, the poppet check valve and solenoid cartridge valve S2.
- 2) When the plow contacts an object, the force of the impact increases the hydraulic pressure in the base end of the cylinder. When the pressure exceeds the relief valve pressure setting, the relief valve opens allowing oil to flow to the base of the opposite cylinder.

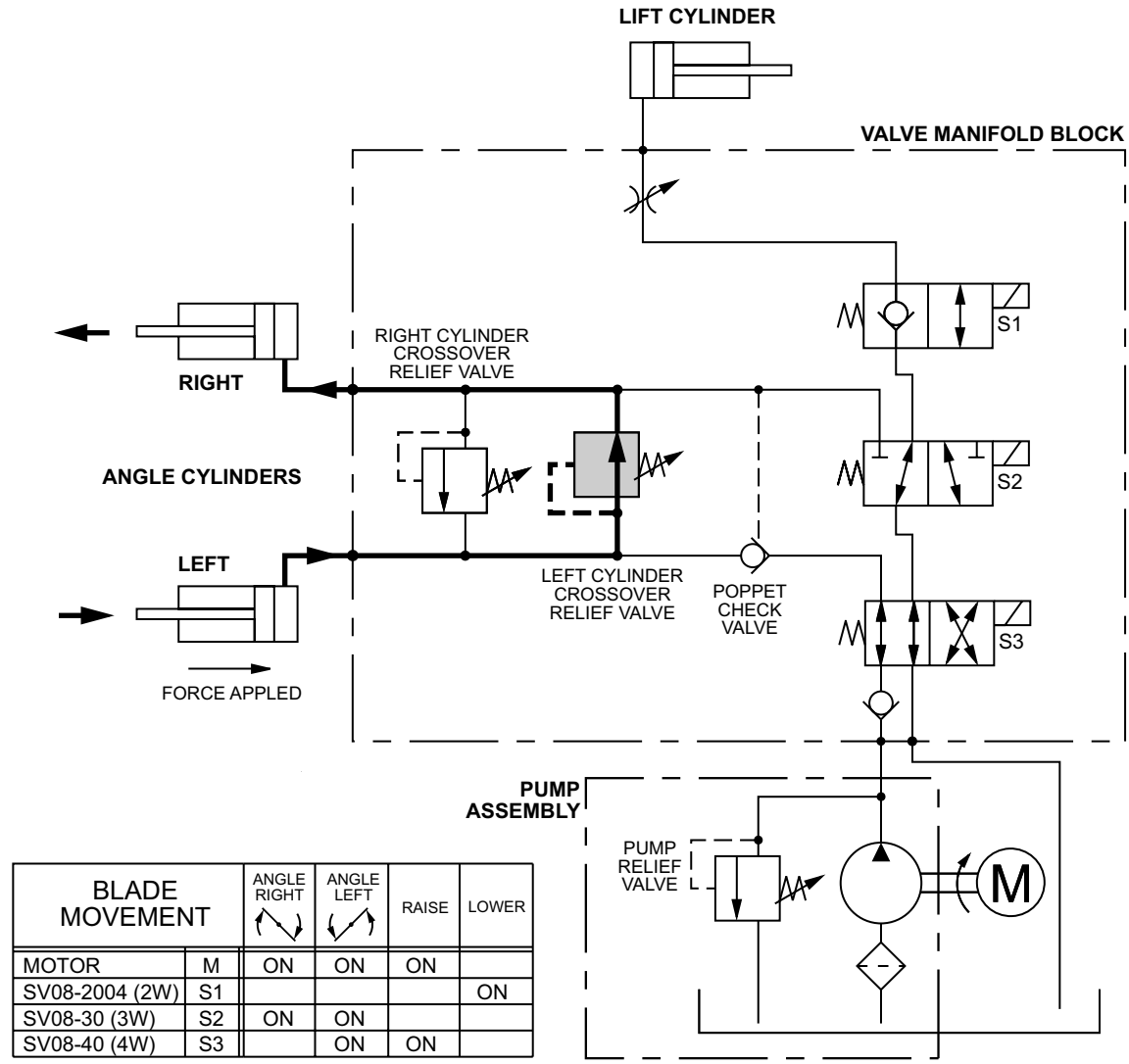

HEADLAMPS – PLOW NOT CONNECTED – 9-PIN ('98 AND OLDER VEHICLES)

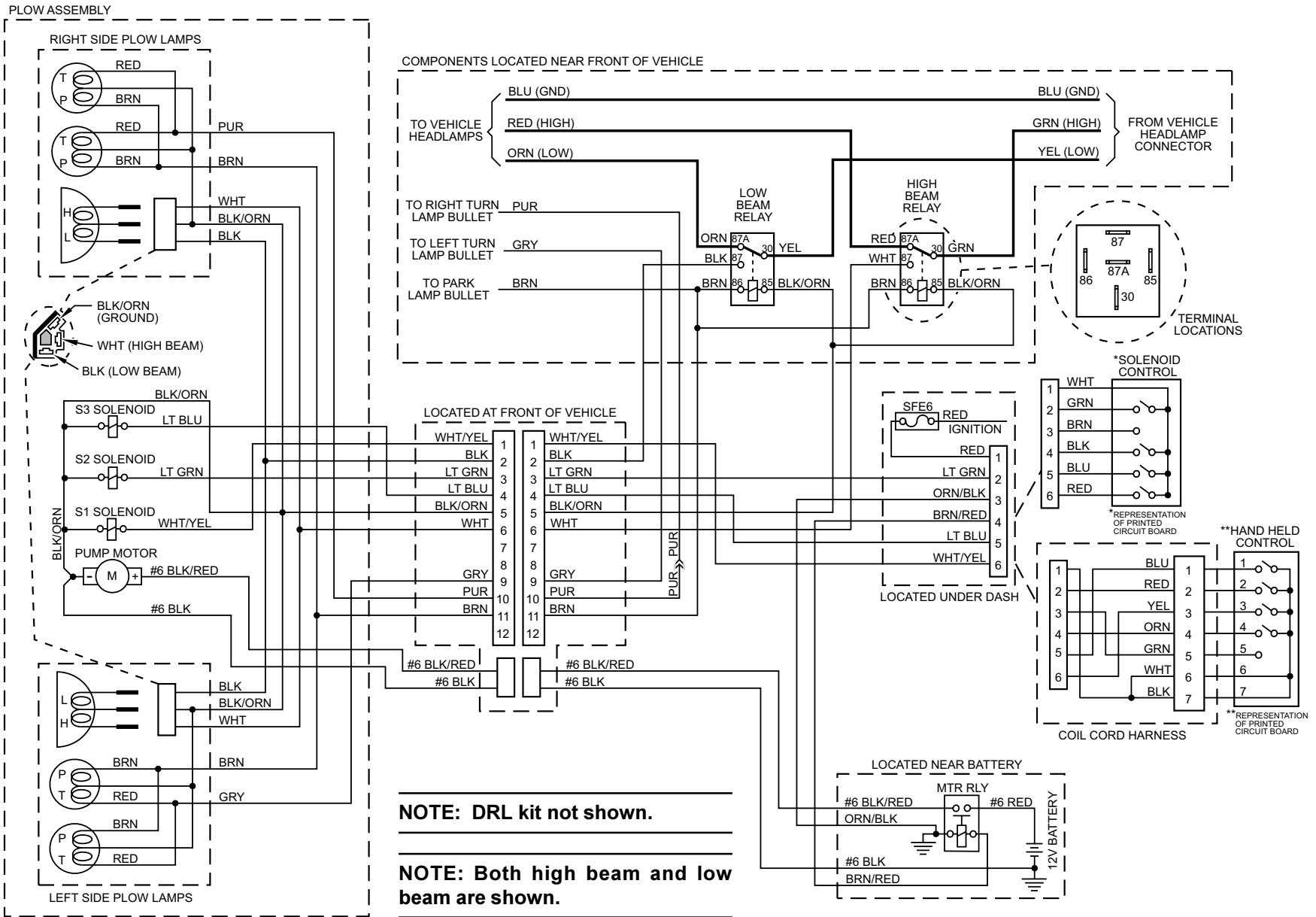

HEADLAMPS – PLOW NOT CONNECTED – 12-PIN ('98 AND OLDER VEHICLES)

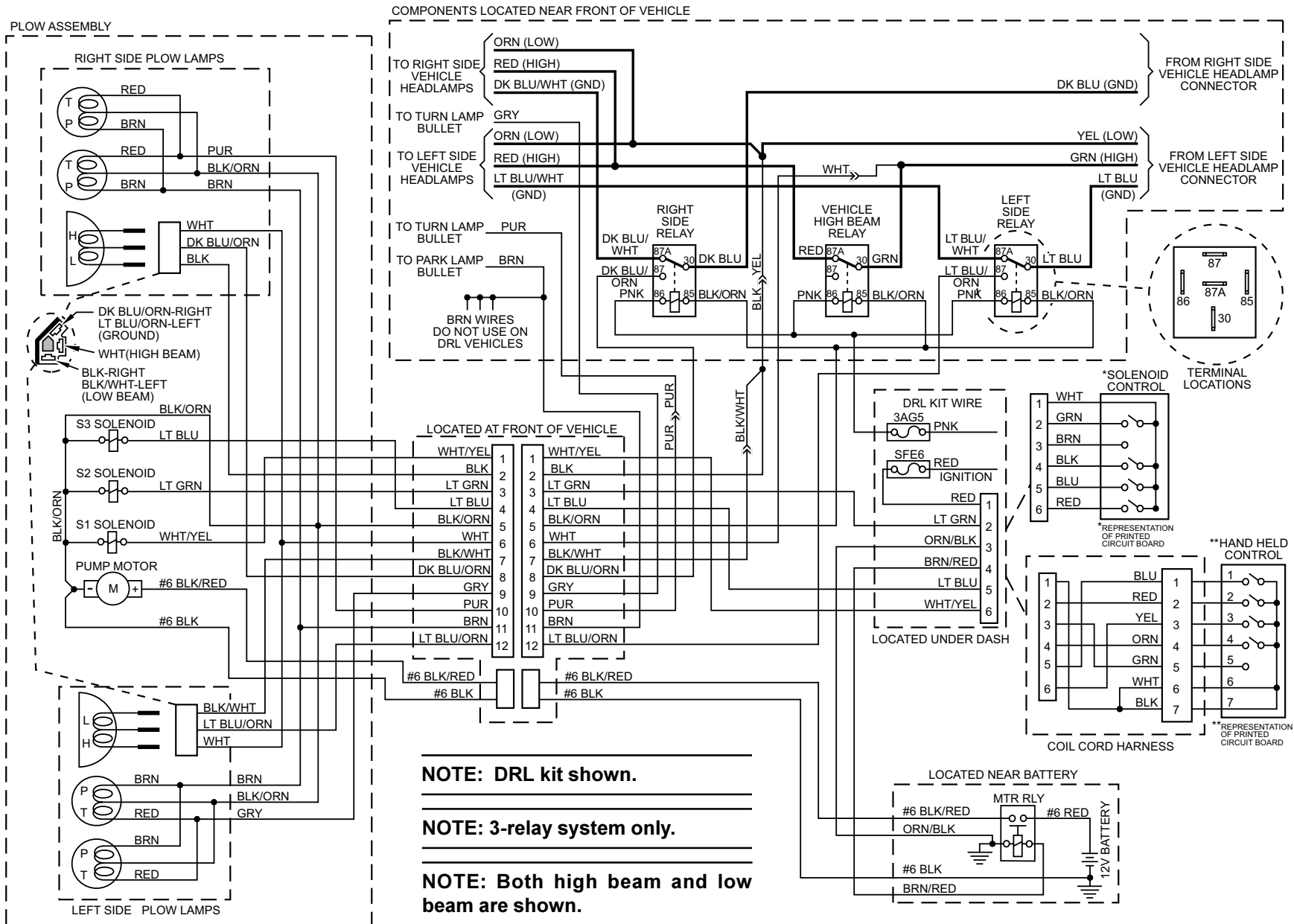

HIGH BEAM HEADLAMPS WITH PLOW CONNECTED TO VEHICLE – 9-PIN ('98 AND OLDER VEHICLES)

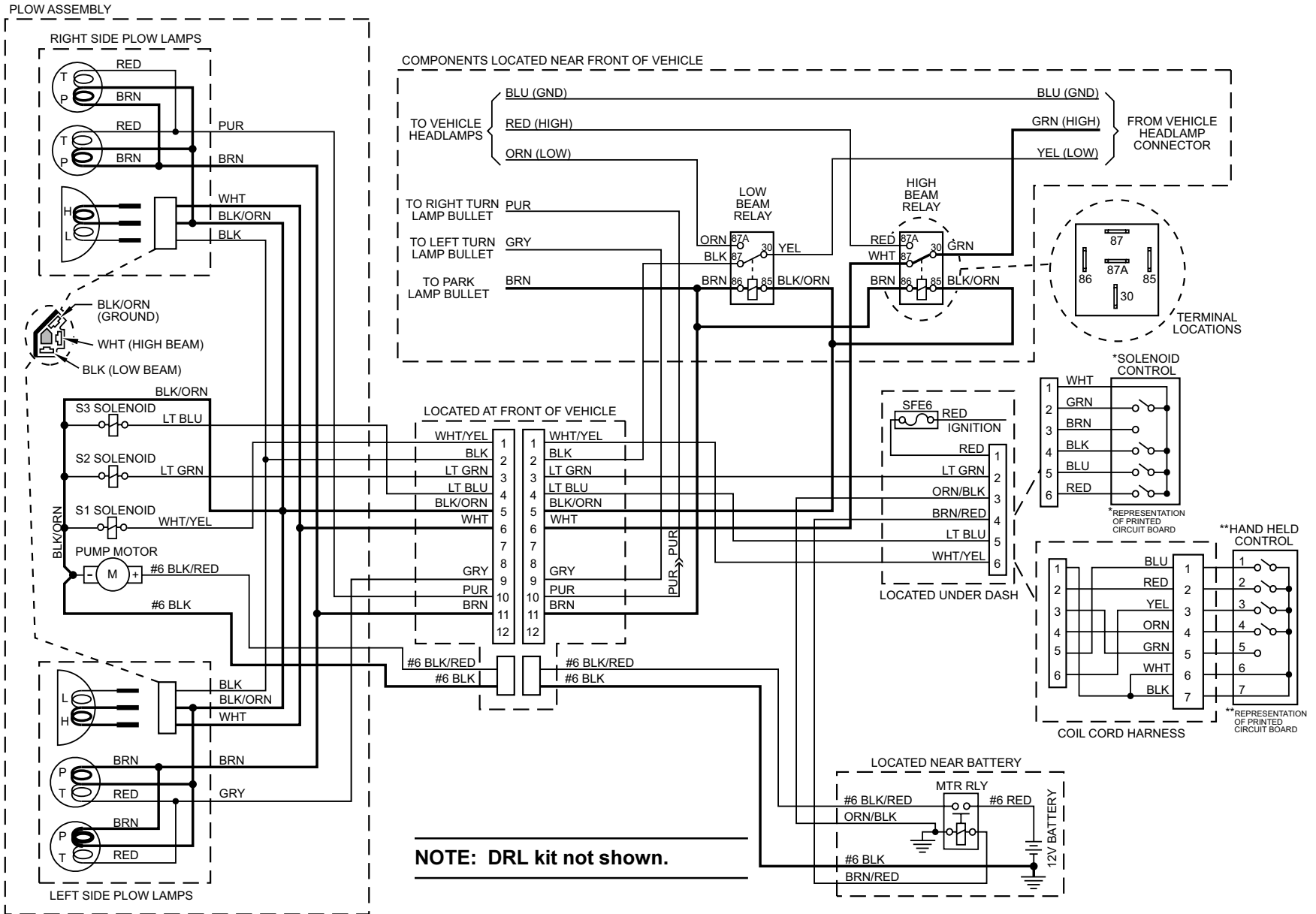

HIGH BEAM HEADLAMPS WITH PLOW CONNECTED TO VEHICLE – 12-PIN ('98 AND OLDER VEHICLES)

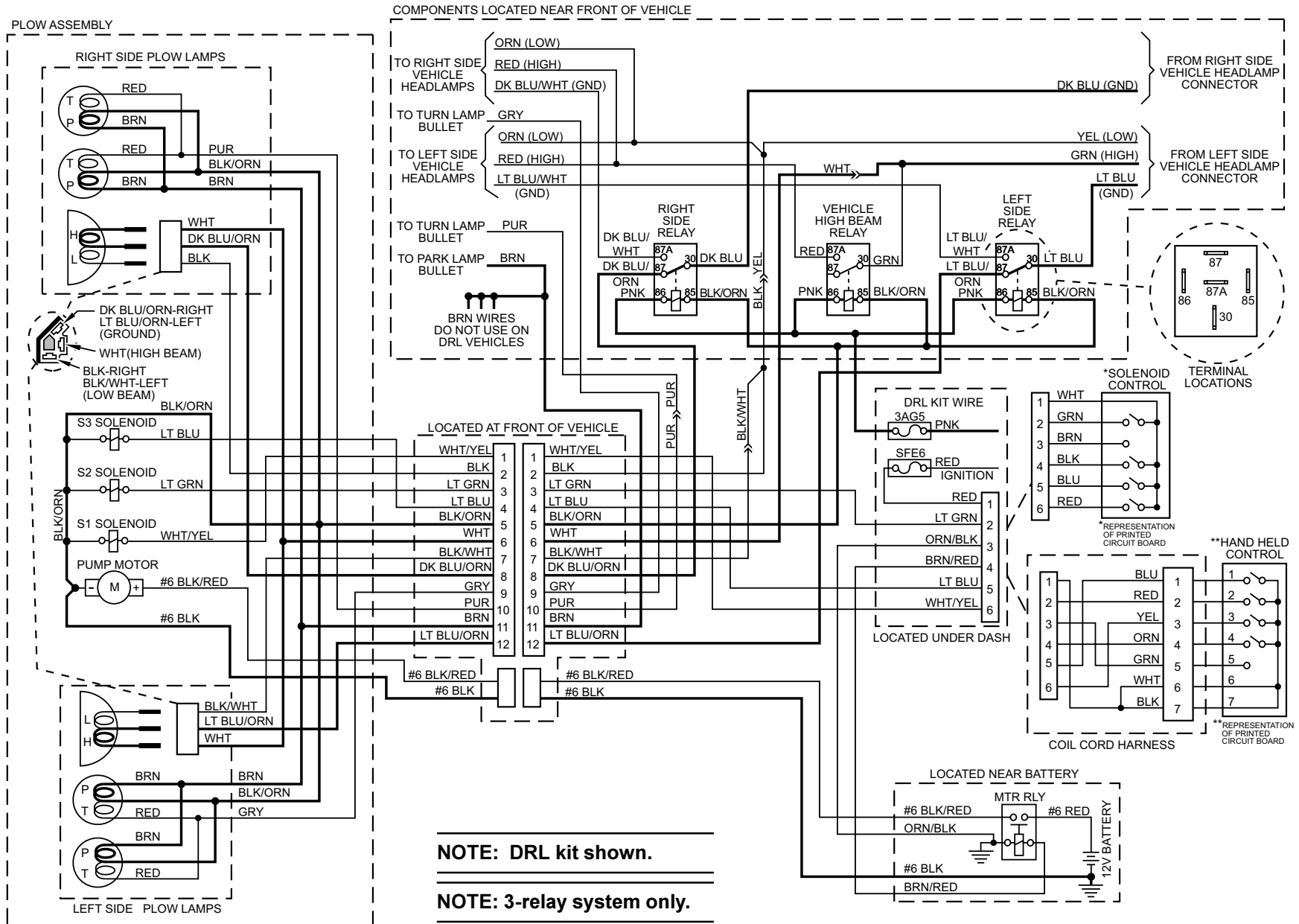

LOW BEAM HEADLAMPS WITH PLOW CONNECTED TO VEHICLE – 9-PIN ('98 AND OLDER VEHICLES)

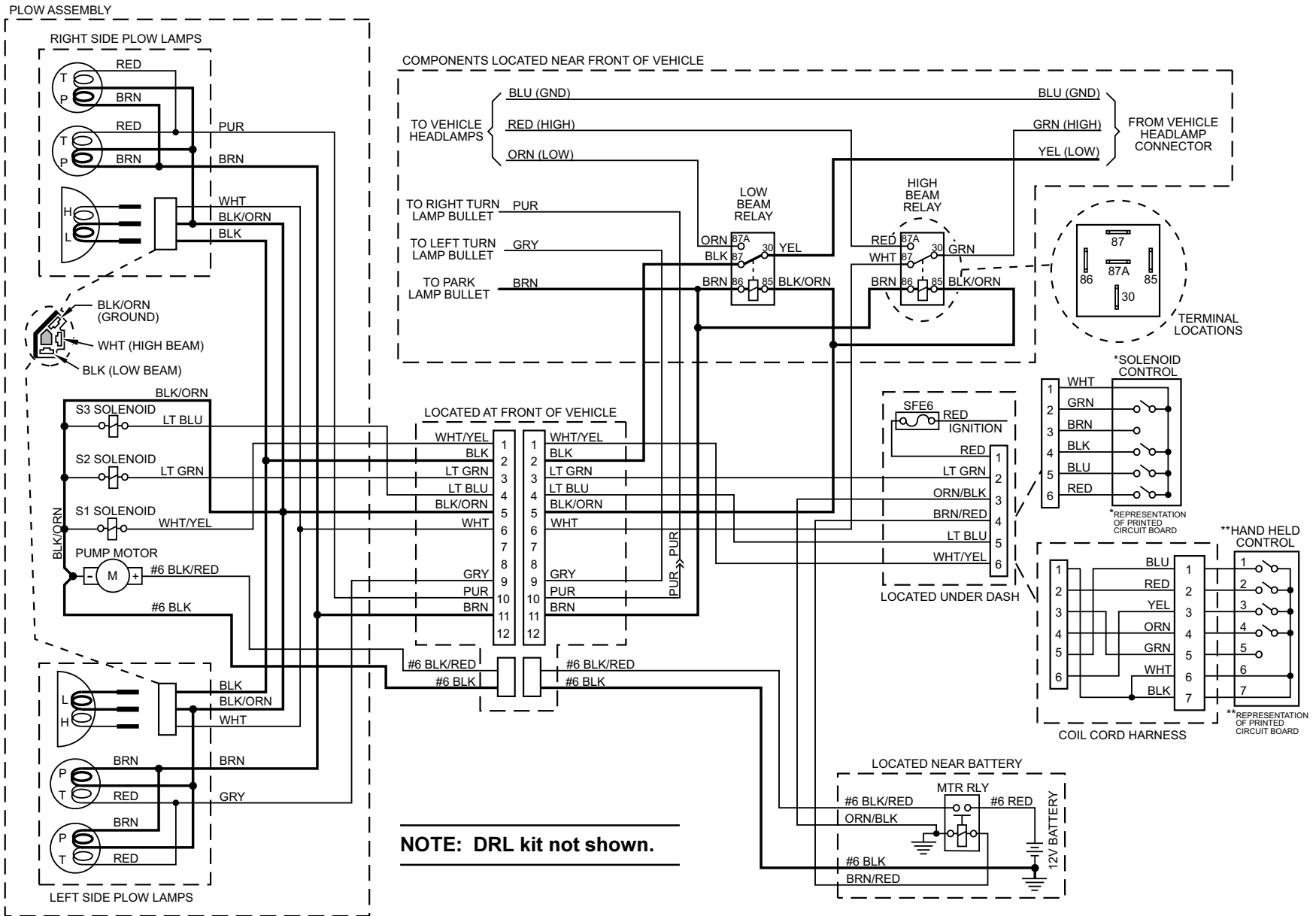

LOW BEAM HEADLAMPS WITH PLOW CONNECTED TO VEHICLE – 12-PIN ('98 AND OLDER VEHICLES)

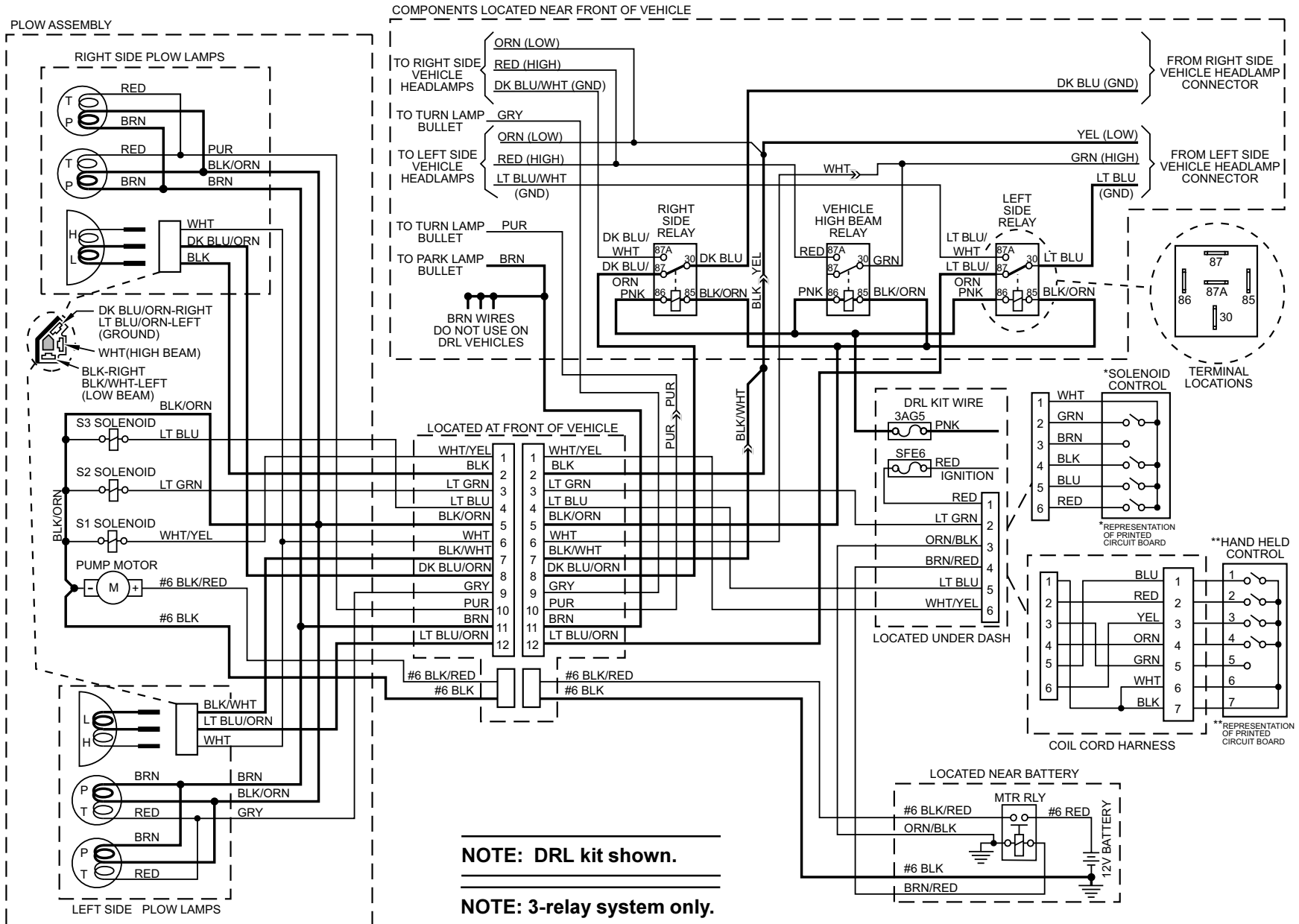

TROUBLESHOOTING GUIDE

Troubleshooting Guide Contents

General Diagnostic Table	36
Packing Nut Adjustment	39
Motor Test	40
Motor and Motor Relay Test Diagram	41
Motor Relay Test	42
Vehicle Harness Test – Motor Relay	43
Control Test	44
Pump Pressure Test	46
Cartridge Coil Activation Test	48
Vehicle Harness Test – Cartridge Coils	49
Hydraulic System Test	50
Crossover Relief Valve Inspection and Adjustment	51
Poppet Valve Inspection	52
Individual Solenoid Coil Test	53
Solenoid Cartridge Valve Inspection	53
Headlamp Test Diagram – 9-Pin	54
Vehicle Headlamp Test – 9-Pin	55
Plow Headlamp Test – 9-Pin	56
Plow Park/Turn Lamp Test – 9- or 12-Pin	57
Optional Park/Turn Relay Kit Test ...	58
Optional Park/Turn Relay Kit Schematics	59
Vehicle Headlamp Test – 12-Pin	60
Plow Headlamp Test – 12-Pin	62
Headlamp Test Diagram – 12-Pin ...	64

Introduction

This guide consists of a series of tables, diagrams, flow charts and other information. When used properly it will assist the mechanic in identifying and repairing malfunctioning system components. Western Products highly recommends the use of the UniMount® Electrical Tester as a timesaving option for electrical system diagnosis. When using this tester, refer to the supplied instruction manual for proper use of the tester.

Any malfunction of the snowplow can be categorized as either mechanical, electrical or hydraulic. Mechanical issues are generally related to the blade, framework and mount components and are usually identified by visual inspection. Electrical and hydraulic issues can sometimes be difficult to trace to the component level and that is the purpose of this troubleshooting guide.

Read and understand the Theory of Operation before attempting troubleshooting.

How to Use the Troubleshooting Guide

When diagnosing the snowplow electrical and hydraulic systems, many variables need to be eliminated in order to obtain workable test procedures. These variables translate into conditions listed before the tables or flow charts and must be satisfied before proceeding.

If the listed conditions are not met, the procedure can result in inaccurate results and wasted time.

In many cases, satisfying the listed conditions alone will solve the problem.

1. Go to the General Diagnostic Table and satisfy the nine listed conditions. These conditions must be met before proceeding into the table or to any subsequent test.
2. Locate the condition in the table which best describes the problem and check possible causes and actions in the order listed.
3. Proceed to a service procedure, another condition, or a specific test as directed. All tests except the Hydraulic System Test use a flow chart format. To use these flow charts, first satisfy any listed conditions at the top of the page.

Then begin at the upper left square and proceed as directed.

4. Follow along sequentially through the table and tests, referring to the hydraulic and electrical schematics in the Theory of Operation section and the component Identification and Location diagrams. Eventually the problem will be pinpointed at the component level.

Electrical Testing

Read and understand the Theory of Operation section. A simple 12V test light with a ground lead can be used for circuit testing. When directed to check for 12 volts (12V), ground the test lamp lead and probe the terminal. When asked to check for ground, attach the test lamp lead to +12V and probe the terminal. Note that 12V is a nominal value. If using a voltmeter, actual voltage will vary with the vehicle and presence of loads in tested circuits. Continuity alone does not guarantee a good circuit. Poor connections or damaged wires may have continuity but be unable to carry sufficient current.

GENERAL DIAGNOSTIC TABLE

BEFORE USING THIS GENERAL DIAGNOSTIC TABLE OR PERFORMING ANY TESTS, YOU MUST VERIFY THE FOLLOWING CONDITIONS:

1. Snowplow is attached to vehicle and all harnesses are connected.
2. Harness connector pins and terminals are free of corrosion, insuring good connections, and coated with dielectric grease.
3. Vehicle battery and charging system are in good condition and battery connections are clean and tight.

⚠ CAUTION

Do not mix different types of hydraulic fluid. Some fluids are not compatible and may cause performance problems and product damage.

4. Hydraulic reservoir is filled to filler plug level with recommended fluid, when lift cylinder is fully retracted. See Product Specifications.

5. There are no oil leaks from hoses, fittings, cylinders or the hydraulic unit.
6. All built up snow and ice is removed from the snowplow.
7. 6 amp fuse* in vehicle harness is good.

8. Ignition is turned on or engine is running.
 9. The control is connected in the cab and turned on.
- *Early revision harnesses may have a 10 amp fuse.

CONDITION	POSSIBLE CAUSE	ACTION
Motor does not run for any requested function.	Poor connections in vehicle or snowplow battery cables.	Clean and re-establish connections.
	Motor worn or damaged or pump seized.	Go to Motor Test.
	Motor relay inoperative.	Go to Motor Relay Test.
	Open circuit in vehicle wiring harness.	Go to Vehicle Harness Test - Motor Relay.
	Malfunctioning controller.	Go to Control Test.
Motor runs continuously.	Motor relay sticking or always energized.	Go to Motor Relay Test.
	Short circuit in vehicle wiring harness.	Go to Vehicle Harness Test - Motor Relay.
	Malfunctioning controller.	Go to Control Test.
Snowplow won't raise – motor runs.	Lift cylinder packing nut too tight.	Adjust lift cylinder packing nut.
	Clogged pump filter (all functions are affected).	Clean or replace filter, flush reservoir.
	Worn or damaged pump.	Go to Pump Pressure Test.
	Poor connections on battery cables.	Inspect battery cables, clean and re-attach all connections.

GENERAL DIAGNOSTIC TABLE

CONDITION	POSSIBLE CAUSE	ACTION
Snowplow won't raise – motor runs. (cont.)	Solenoid valve coil not activating properly.	Go to Solenoid Coil Activation Test.
	Hydraulic system malfunction.	Go to Hydraulic System Test.
	Malfunctioning controller.	Go to Control Test.
Snowplow raises slowly or partially – motor runs.	Lift cylinder packing nut too tight.	Adjust lift cylinder packing nut.
	Clogged pump filter (all functions are affected).	Clean or replace filter, flush reservoir.
	Worn or damaged pump.	Go to Pump Pressure Test.
	Poor connections on battery cables.	Inspect battery cables, clean and re-attach all connections.
	Quill adjusted in too far.	Adjust quill out.
	Malfunctioning controller.	Go to Control Test.
Snowplow will not lower or lowers slowly, or won't float.	Quill adjusted in too far.	Adjust quill out.
	Lift cylinder packing nut too tight.	Adjust lift cylinder packing nut.
	Lift cylinder packing dried out.	Loosen packing nut, lubricate rod, operate cylinder until it moves easily, adjust packing nut.
	Solenoid valve coils not activating properly.	Go to Solenoid Coil Activation Test.
	Hydraulic system malfunction.	Go to Hydraulic System Test.
	Malfunctioning controller.	Go to Control Test.
Snowplow lowers by itself or won't stay in raised position.	Solenoid valve coils not activating properly.	Go to Solenoid Coil Activation Test.
	Hydraulic system malfunction.	Go to Hydraulic System Test.
	Malfunctioning controller.	Go to Control Test.
Blade will not hold angled position.	Air in angle cylinders.	Cycle angle functions to purge cylinders.
	Oil bypassing cylinder relief valve.	Go to Relief Valve Inspection and Adjustment.
	Hydraulic system malfunction.	Go to Hydraulic System Test.
Plow does not perform the selected function or performs a different function.	Hydraulic hose routing incorrect.	Verify correct hose installation. See Hose Routing Diagram.
	Solenoid valve coils not activating properly.	Go to Solenoid Coil Activation Test.
	Hydraulic system malfunction.	Go to Hydraulic System Test.
	Malfunctioning Controller.	Go to Control Test.

GENERAL DIAGNOSTIC TABLE

CONDITION	POSSIBLE CAUSE	ACTION
Vehicle harness 6 amp fuse blows.	Red wire in vehicle harness is shorted to ground.	Repair wire or replace vehicle harness.
	Motor relay primary coil shorted internally.	Check primary coil with ohmmeter. Replace defective motor relay.
	Solenoid valve coil shorted internally.	Go to individual coil test. Replace shorted coils.
	Motor relay or solenoid coil wires in vehicle harness shorted to ground.	Repair wire or replace vehicle harness.
	Solenoid coil wires in plow harness shorted to ground.	Repair wire or replace plow harness.
	Malfunctioning controller.	Go to Control Test.
Vehicle accessory fuse blows.	Circuit overloaded.	Consult vehicle owner's manual for correct application of aftermarket electrical loads.
Excessive load on vehicle electrical system while using snowplow.	Poor connections in battery cables.	Inspect battery cables, clean and re-establish all connections.
	Angle or lift cylinder packing nut too tight.	Adjust cylinder packing nut.
	Worn or damaged pump or motor.	Go to Pump Pressure Test/check motor.
Snowplow headlamps operate irregularly or not at all – snowplow attached. -or- Vehicle headlamps operate irregularly or not at all – snowplow removed.	Burned out bulbs or corroded sockets.	Replace bulbs, clean contacts.
	Wires improperly connected to relays.	Review and correct wire installation. See Headlamp Test Diagram.
	Headlamp relay inoperative.	Go to Plow Headlamp Test or Vehicle Headlamp Test.
Vehicle daytime running lamps (DRLs) do not work – snowplow removed. ('98 and older vehicles)	Parking brake on.	Fully release parking brake.
	Power in DRL circuit has been interrupted.	Turn lamp and/or ignition switch on and off to cycle the DRL circuitry.
	No output from DRL module.	Repair vehicle electrical system.
Blade will not hold position.	Hydraulic system malfunction.	Go to Hydraulic System Test.
Snowplow Park or Turn lamps operate intermittently or not at all – snowplow attached.	Burned out bulb, corroded socket(s) or poor electrical connection.	Replace bulbs/clean contacts. If necessary, go to Park/Turn Lamp test.

PACKING NUT ADJUSTMENT

Periodically verify the lift cylinder and angle cylinder packing nuts have not loosened. If a packing nut is loose or excessive leakage appears when activating the cylinder, tighten the packing nut 1/4 turn maximum after you feel the packing nut contact the packing.

⚠ CAUTION

Do not overtighten the packing nut. Over-tightening affects plow operation and the life of the packing.

NOTE: A small amount of leakage is necessary to properly lubricate the cylinder rod.

The lift or angle cylinder packings may dry out if the plow is not used for a period of time. If the lift arm is difficult to push completely down when the control is in float, or the plow angles slowly and causes excessive load on the motor, loosen the lift or angle cylinder packing nuts, lubricate the cylinder rods with oil and cycle the plow using the control. When the packings are lubricated, tighten the packing nuts and recheck operation.

MOTOR TEST

⚠ WARNING

The driver shall keep bystanders clear of the blade during this test. Do not stand between the vehicle and the blade. A moving or falling blade could cause personal injury.

Refer to the Motor and Motor Relay Test Diagram.

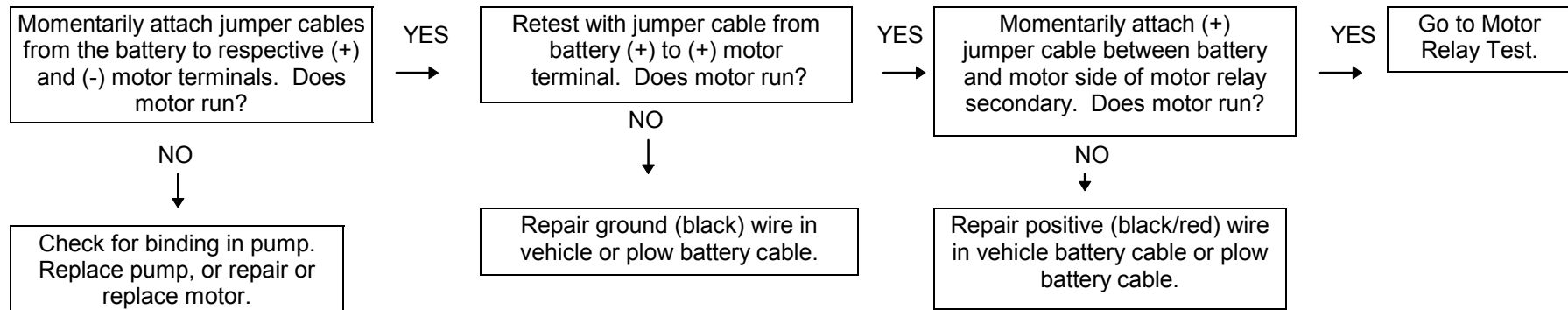

MOTOR AND MOTOR RELAY TEST DIAGRAM

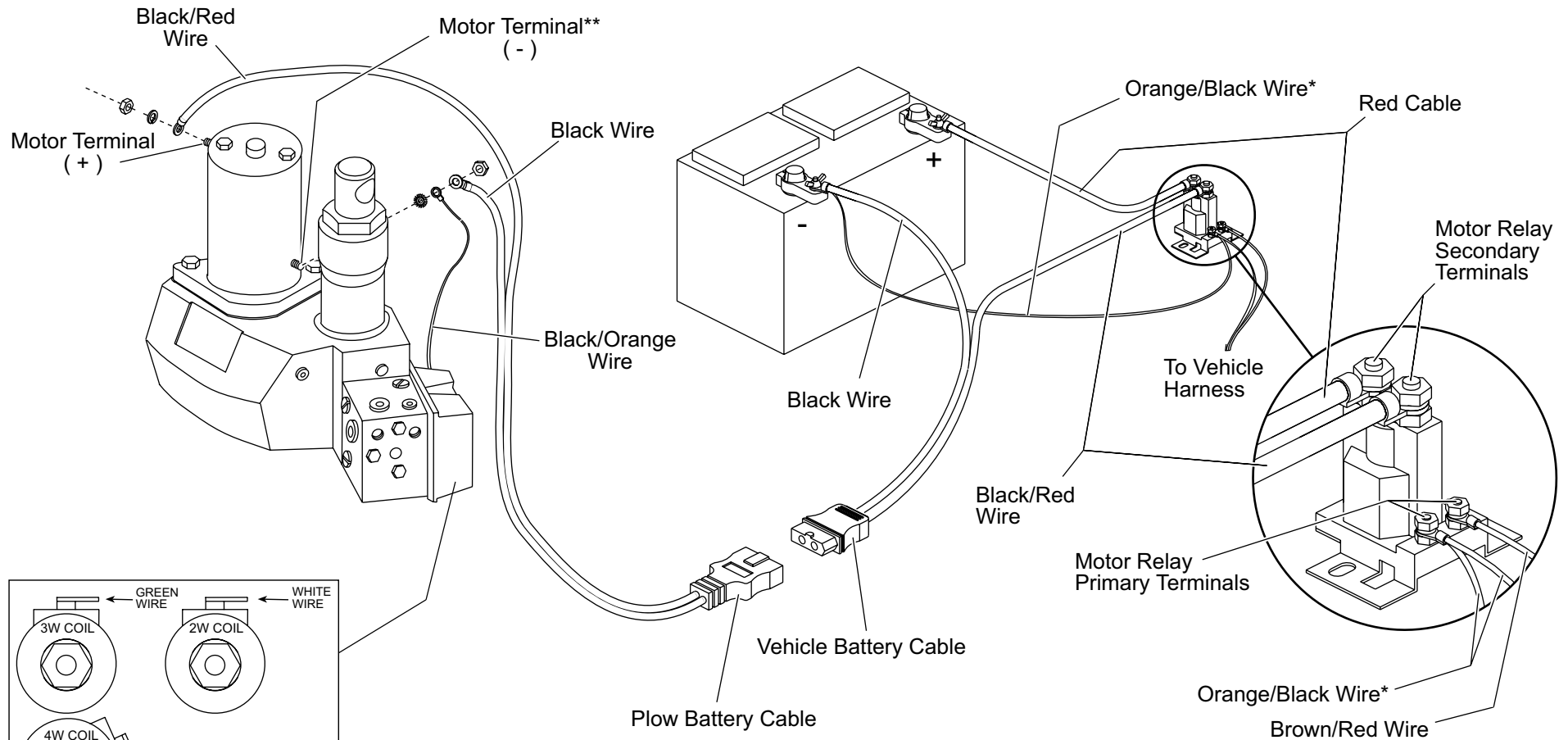

GREEN WIRE
 WHITE WIRE
 3W COIL
 2W COIL
 4W COIL
 BLUE WIRE

ELECTRICAL CONNECTIONS:
 Colored wires as shown.
 Black wire tabs, one to each coil.
SOLENOID VALVE TORQUE:
 Cartridges – 10 ft. lbs.
 Coils – 5 ft. lbs.

56294

DIAGRAM INSIDE COVER

- * Later revision harness only. Early revision harness has a single black/orange wire to motor relay only, unless modified for use with hand-held control.
- ** Early production motors use cap screw and star washer. Current production motors have a stud.

MOTOR RELAY TEST

⚠ WARNING

The driver shall keep bystanders clear of the blade during this test. Do not stand between the vehicle and the blade. A moving or falling blade could cause personal injury.

1. Jumper power and ground directly from battery to motor to verify that the motor runs. Make final connection at the motor.
2. Refer to the Motor and Motor Relay Test Diagram, and Vehicle Harness and Vehicle Cable Location Diagram.

Motor does not run:

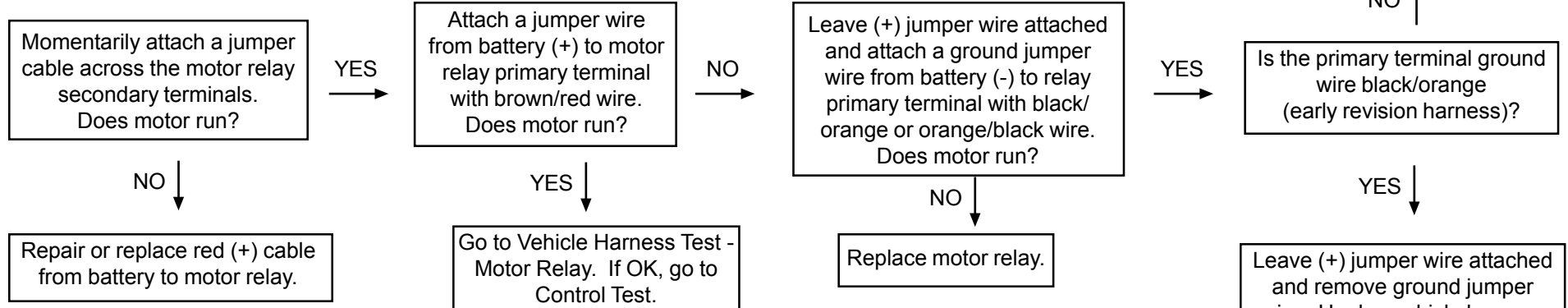

Motor runs continuously:

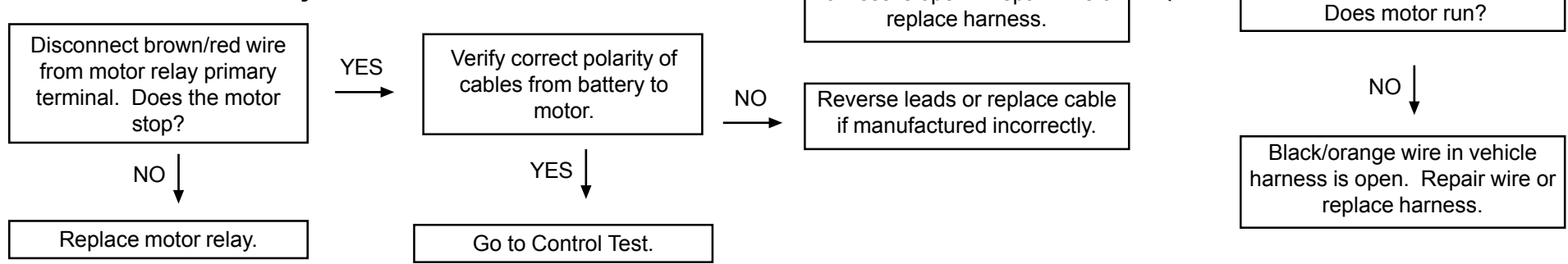

VEHICLE HARNESS TEST – MOTOR RELAY

⚠ WARNING

The driver shall keep bystanders clear of the blade during this test. Do not stand between the vehicle and the blade. A moving or falling blade could cause personal injury.

1. Perform the Motor Test and Motor Relay Test first.
2. Disconnect the control in the cab.
3. Refer to the 6-Pin Connector diagram. Test the vehicle side of the connector in the cab as follows.

White 6-Pin Connector on vehicle harness—located in cab (end view)

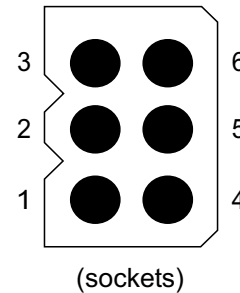

Pin #	Wire Color
1	Red
2	Lt Green
3	Orange/Black
4	Brown/Red
5	Lt Blue
6	White/Yellow

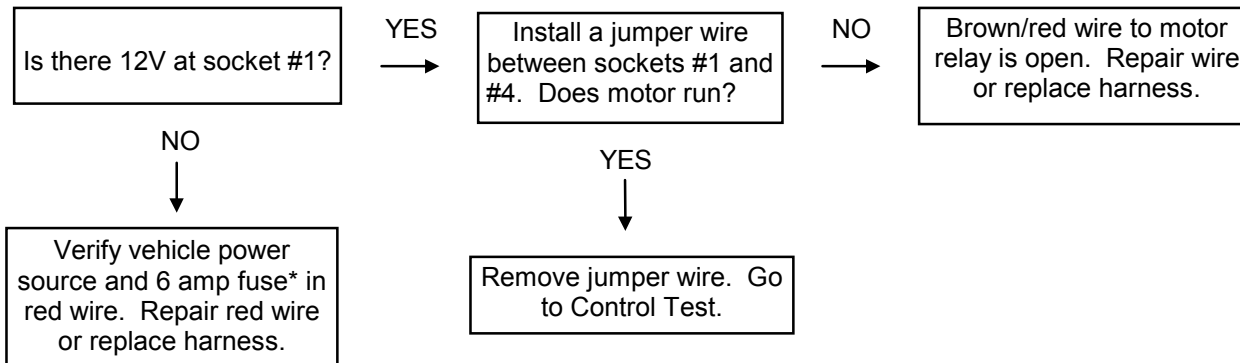

*Early revision harnesses may have a 10 amp fuse.

CONTROL TEST

Test Procedure for Hand-Held or Solenoid Control

1. Disconnect the control in the cab and remove to work bench.
2. Refer to the 6-Pin Connector diagram and the chart.
3. Using a 12V power source with a 6 amp fuse in the positive lead, carefully apply +12V to pin #1 and ground to pin #3 of the 6-pin connector.
4. Turn the control on. Power indicator lamp should be lit. Using a grounded test light, check for 12V at each of pins #2, 4, 5, 6 when the control is activated for each function. Footnotes in the chart indicate special conditions of control operation.
5. Compare the control outputs for all functions with the chart and proceed to the flow diagram.

Pin No.	Purpose	Angle Right (c)	Angle Left (c)	Raise (d)	Lower/Float (e)
1	12V Input				
2	S2 Output (3-Way)	ON	ON		
3	Ground				
4	Motor Relay Output	ON (b)	ON (b)	ON (b)	
5	S3 Output (4-Way)		ON	ON	
6	S1 Output (2-Way)	(a)	(a)		ON

- a. S1 output will be ON if control is in float. Activate raise function to cancel float. If hand-held control is in float, S1 output will turn off while angle button is pressed and on when the button is released.
- b. For hand-held control, motor relay output turns off before solenoid coil outputs when button is released.
- c. For hand-held control, outputs turn off after button is held for approximately 5 seconds.
- d. For hand-held control, outputs turn off after button is held for approximately 2.5 seconds.
- e. Solenoid control activates S1 output in float when lever is moved to lower position. Hand-held control activates float when lower button is held for .75 second.

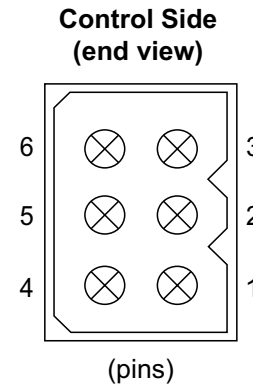

Pin #	Solenoid Control Wire Color Only
1	White
2	Green
3	Brown
4	Black
5	Blue
6	Red

CONTROL TEST

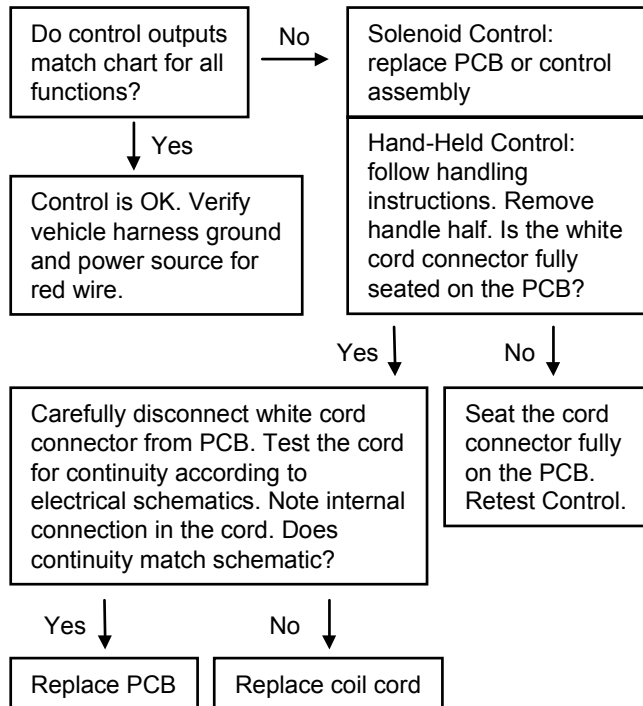

NOTE: For hand-held control, poor ground connections or high or low voltage will shut the control off.

To Safely Handle Hand-Held PCB:

⚠ CAUTION

Printed circuit board (PCB) is subject to damage from static electricity. Follow instructions below to safely handle PCB.

1. Disconnect the control in the cab and remove to a workbench.
2. Place control on its left side and remove right side of handle, leaving the keypad/circuit board assembly in left half.
3. Touch hand to any grounded metal object to discharge possible static buildup.
4. Remove keypad/circuit board assembly from housing by only touching the edges of the keypad/circuit board assembly.
5. The keypad/circuit board assembly can be handled safely as long as contact with it is maintained.

PUMP PRESSURE TEST

⚠ WARNING

The tester shall keep bystanders clear of the blade during this test. Do not stand between the vehicle and the blade. A moving or falling blade could cause personal injury.

1. Lower blade to the ground and fully collapse the lift cylinder.
2. Carefully remove the 1/4" pipe plug from the lift cylinder test port in the housing above the manifold block. Be aware of possible

residual pressure in the lift cylinder.

3. Using a suitable adapter fitting, attach a 3000 psi hydraulic pressure gauge to the lift cylinder test port.
4. Activate the raise function with the control and read the pump relief pressure when the blade is fully raised.
5. Refer to the illustration below for pump relief valve screw and lift cylinder test port location. The chart lists relief pressure settings.
6. Proceed to the flow chart on the following page.

Plow Type	Maximum Motor Amp Draw At 11.2 Volts w/Warm Oil	Pump Relief Valve Pressure (± 100 PSI)
Standard, Pro	200	1750
Heavyweight	210	1900
Sport Utility	180	1550

NOTE: Adjusting pump relief valve screw clockwise 1/4 turn increases relief pressure approximately 225 PSI. Early 2-piece die-cast pumps may require removal to adjust.

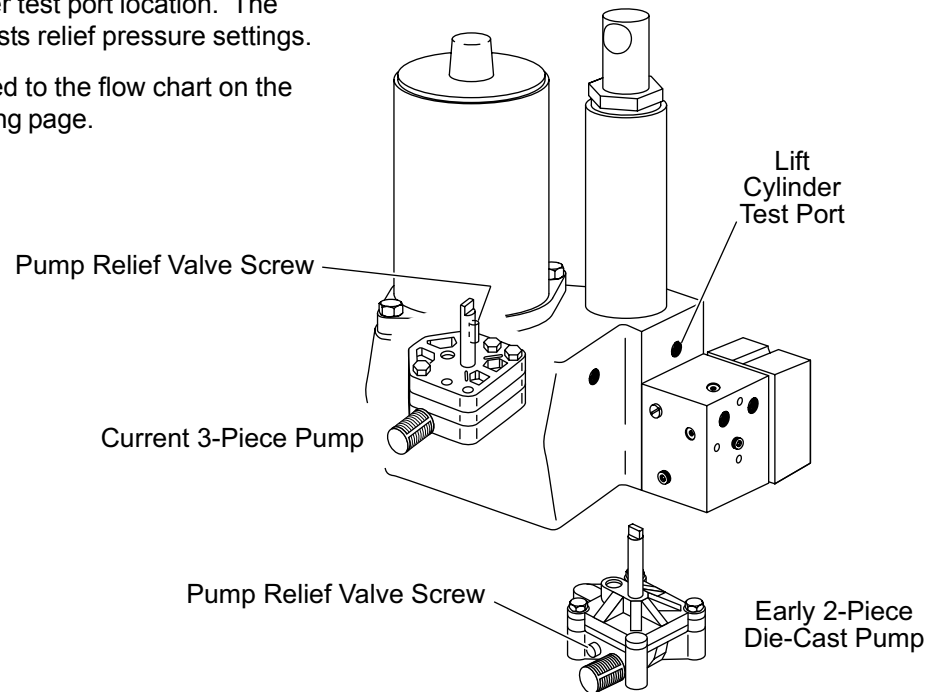

PUMP PRESSURE TEST

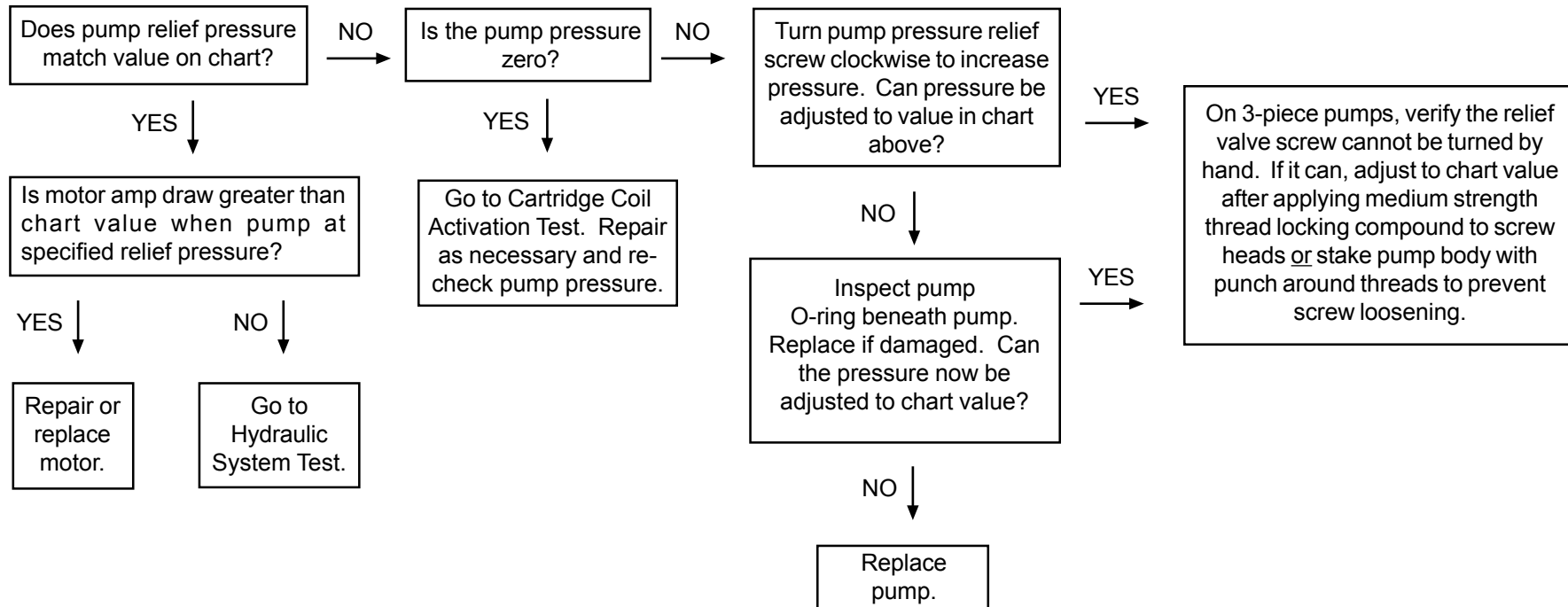

CARTRIDGE COIL ACTIVATION TEST

1. Disconnect the black/red (+) battery cable from the motor and isolate it.
2. Verify wires are properly attached to solenoid coils. Refer to Wire Connection Table, Electrical Schematic, and Solenoid Cartridge Valve Identification and Location.
3. Activate the control for each function and check for magnetic pull at all three solenoid valve coils. Only the coils designated as "ON" in the table should activate for each function. After noting which coils are energized, proceed to the flow chart.

Cartridge Coil Wiring and Activation – Wire Connection Table

Solenoid Coil	Plow Harness Pin	Wire Color	Angle Right	Angle Left	Raise	Lower
S1 (2-Way)	1	White/ Yellow	*	*	*	ON
S2 (3-Way)	3	Light Green	ON	ON		
S3 (4-Way)	4	Light Blue		ON	ON	

*S1 output will be "ON" for all functions if control is in "FLOAT".

Activate "RAISE" function to cancel "FLOAT".

Hand Held Control Only – While in "FLOAT", pressing and holding the "RIGHT" or "LEFT" button will turn off the solenoid cartridge valve S1 until the button is released.

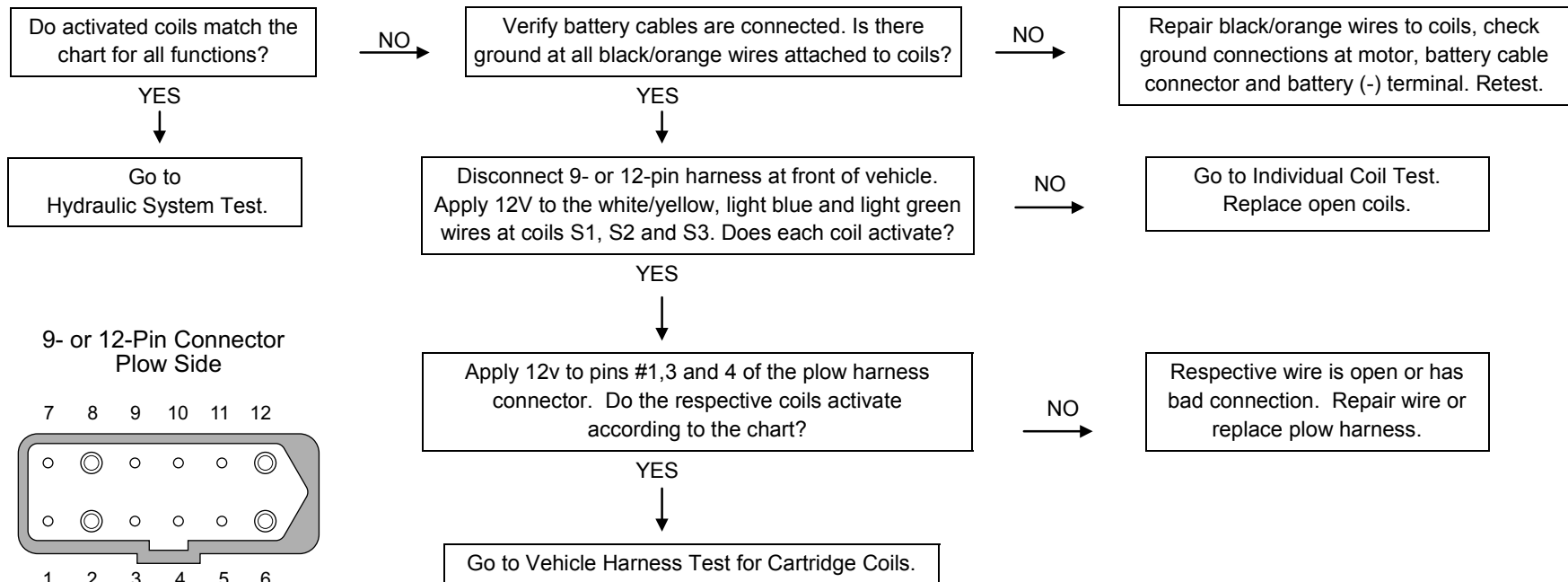

VEHICLE HARNESS TEST – CARTRIDGE COILS

1. Disconnect the black/red (+) battery cable from the motor and isolate it.
2. Perform Cartridge Coil Activation Test.
3. Connect all harness connectors at the front of the vehicle.
4. Refer to the 6-Pin Connector diagram for socket location.

White 6-Pin Connector on vehicle harness—located in cab (end view)

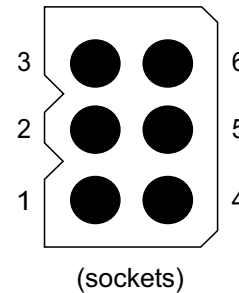

Pin #	Wire Color
1	Red
2	Lt Green
3	Orange/Black
4	Brown/Red
5	Lt Blue
6	White/Yellow

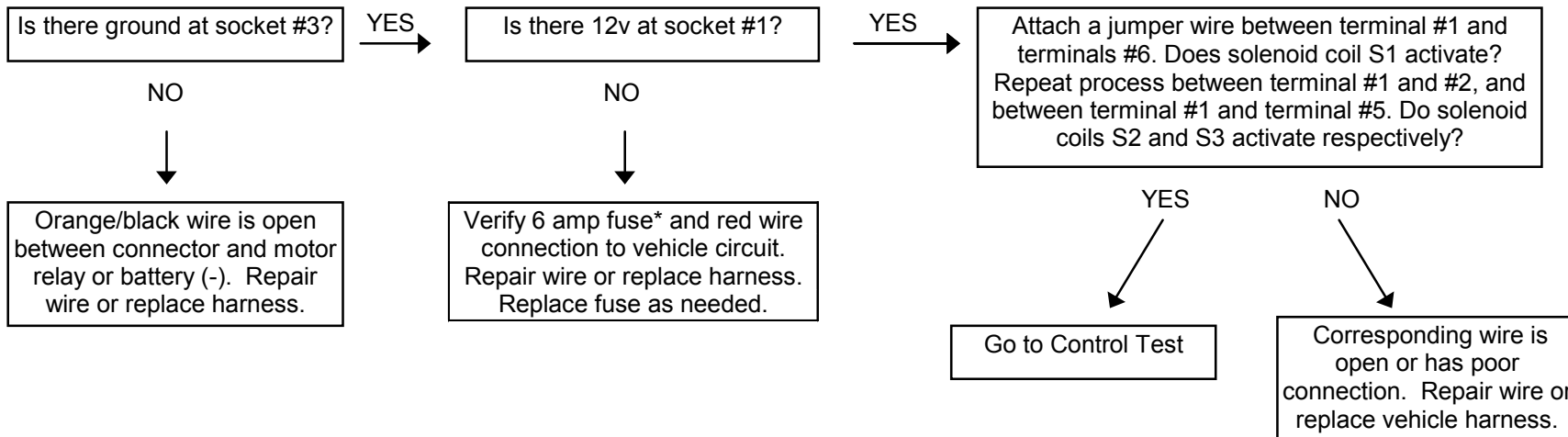

*Early revision harnesses may have a 10 amp fuse.

HYDRAULIC SYSTEM TEST

This test consists of trying all the plow functions and comparing the plow reaction to the action requested in the following table. The table will pinpoint a solenoid valve or poppet check valve problem accurately if only one component is malfunctioning. If the plow reaction for a given function is not listed in the table, there may be a crossover relief or poppet check valve which is

stuck open or contaminated, missing or damaged O-rings or backing rings on cartridge, crossover relief or poppet check valve spool, or there may be two or more malfunctioning components. In this case, use the specific function hydraulic schematic and carefully inspect each component in the flow circuit. If contamination is evident in more than one component, the hydraulic

unit, hoses and cylinders must be completely disassembled, inspected and cleaned.

1. Perform Cartridge Coil Activation Test first.
2. Verify hydraulic hose installation is correct. Refer to the Hose Routing diagram.
3. Test all of the plow functions.

4. Inspect and clean or replace the suspected component. Refer to the Hydraulic Unit Parts Diagram.
5. Refer to the sections following the table for inspection and adjustment of solenoid cartridge valves, poppet check valve and crossover relief valves.

IMPORTANT: *When testing the plow functions, be sure the control is not in "float."*

ACTION REQUESTED	PLOW REACTION	POSSIBLE CAUSE
Angle Right	Angle Left	S3 stuck shifted
	None	S2 not shifted
		Poppet check valve not opening
Angle Left	Angle Right	S3 not shifted
	Raise	S2 not shifted
	None	S2 and S3 not shifted
		Poppet check valve not opening
Raise	None	S3 not shifted
	Angle Left	S2 stuck shifted
None (blade raised)	Lowers	S1 stuck shifted or has leaking internal check valve
Lower	None	S1 not shifted
		S2 stuck shifted
		S3 stuck shifted
None	Drifts Right	S2 stuck shifted
		Contamination or damaged O-rings in crossover relief valve
	Drifts Left	Poppet check valve open
		Contamination or damaged O-rings in crossover relief valve

CROSSOVER RELIEF VALVE INSPECTION AND ADJUSTMENT

Crossover Relief Valve Inspection

1. Remove the valve stem, ball, spacer and spring.
2. Look for broken or damaged parts, contamination or missing or damaged O-rings.

⚠ CAUTION

Be careful to strike the stem squarely. You can bend the stem if you do not strike it squarely.

3. If parts are in good condition, place ball on hard wood block, hold stem seat on ball, and strike stem lightly with a hammer. This will re-conform the seat to the ball.
4. Apply a light coat of anti-seize or grease to stem threads. Lubricate O-ring with hydraulic fluid. Reassemble components into valve block.

Adjustment

1. Adjust by tightening the relief valve stem until it bottoms out (until spring is fully compressed).
2. Back off valve stem (rotate counterclockwise) the number of turns indicated in the Crossover Relief Valve Settings chart.

Crossover Relief Valve Settings

Plow Type	No. of Turns Backed Off (CCW) From Fully Seated*	Crossover Relief Valve Pressure (\pm 100 PSI)
Standard, Pro	1-1/2 – 2	3500
Heavyweight	1-1/2 – 2	3500
Sport Utility	2-1/4 – 2-3/4	2500

* Settings are approximate.

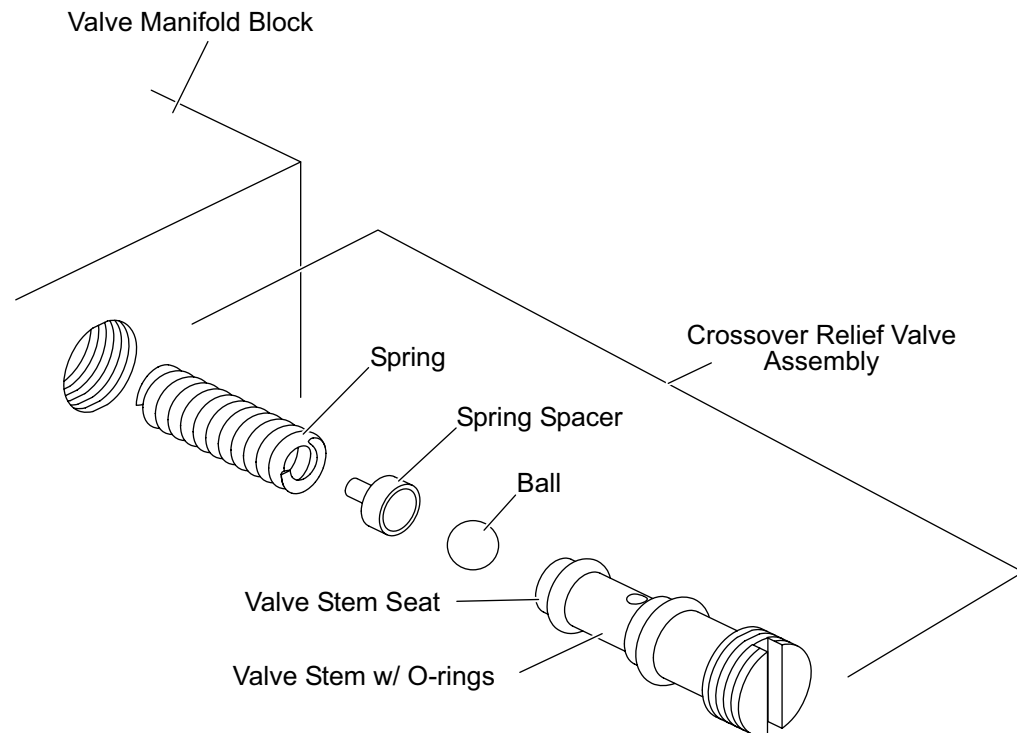

POPPET CHECK VALVE INSPECTION

1. Remove O-ring boss plug, spring and poppet.

NOTE: Strike boss plugs squarely with a hammer to facilitate removal.

2. Remove O-ring boss plug, spring and spool with O-ring. Use long/slender needle-nosed pliers to remove spool.
3. Inspect springs, poppet, spool, O-rings and poppet seat* for wear, damage or contamination.
4. If the valve manifold block has a steel poppet seat, use a strong pencil magnet to push and pull on the seat. If the seat moves at all, replace the valve block.
5. Re-oil O-rings, install spool fully into bore. Spool must insert smoothly.
6. Install poppet, springs and O-ring boss plugs. Torque O-ring boss plug to 60 in-lb.

* Early valve manifolds have the poppet seat machined into the block. Current valve manifolds use a pressed-in steel poppet seat.

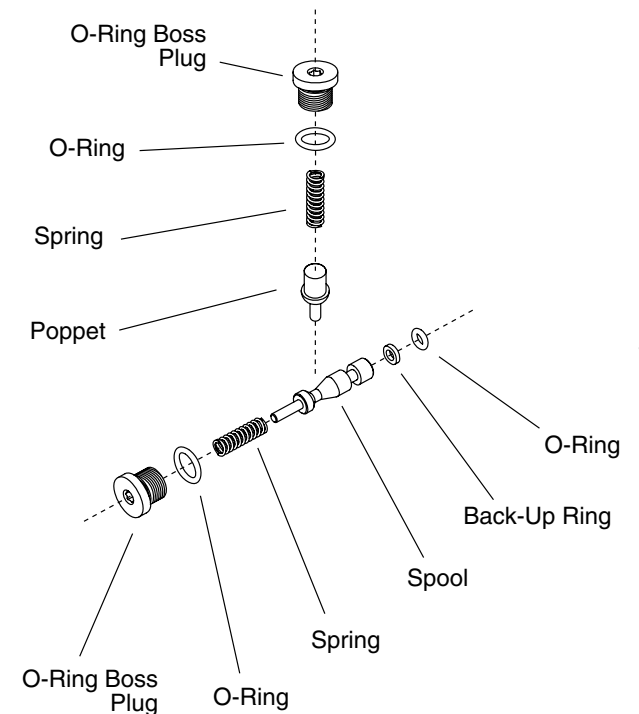
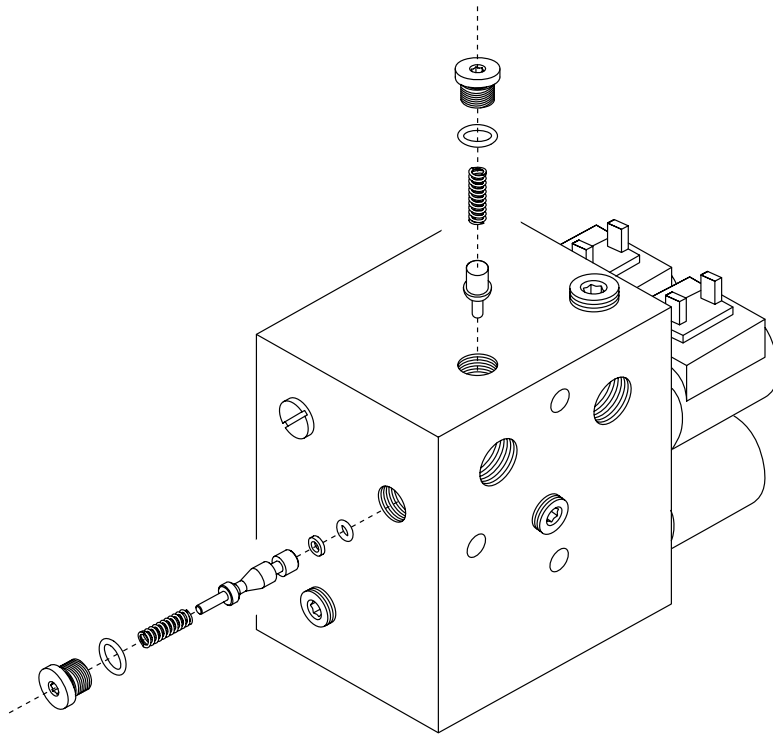

INDIVIDUAL SOLENOID COIL TEST

1. Remove both wires from coil terminals.
2. Attach an ohmmeter across the coil terminals.
3. A reading of approximately 6.7 ohms indicates the coil is good.

NOTE: A good coil will draw approximately 1.5 amps.

SOLENOID CARTRIDGE VALVE INSPECTION

1. Remove coils from the solenoid cartridge valves and remove the cartridge valves from the manifold. Look for visible contamination or damaged seals. Check for stuck spools with a plastic, aluminum, or soft brass probe by pushing on the spring loaded internal spool from the end of the valve. The spool should move freely through its entire travel. Spool travel is approx. 0.070".

NOTE: Using probe to move spool may shear contamination which was affecting spool movement.

2. Bench test the cartridge valve by installing a coil on the stem and applying 12V and ground. Watch through the side ports for internal spool travel.
If the cartridge valve spool is stuck or its travel is restricted, replace the cartridge. If the cartridge valve appears to be in good condition, clean it with parts cleaning solvent and dry with compressed air, being careful not to damage the seals. **Check the spool travel again in case any internal contaminants were dislodged during cleaning.** Re-oil the cartridge valve seals

and o-rings and reinstall the cartridge valve, torquing to 10 ft-lb. Install the coils and torque the retaining nuts to 4 ft-lb.

NOTE: If contamination is seen in more than one component, it can reasonably be assumed that the entire system is contaminated. In order to perform a proper repair, the entire hydraulic unit, including hoses and cylinders, must be disassembled and cleaned. The source of the contamination must be located and repaired before reassembly.

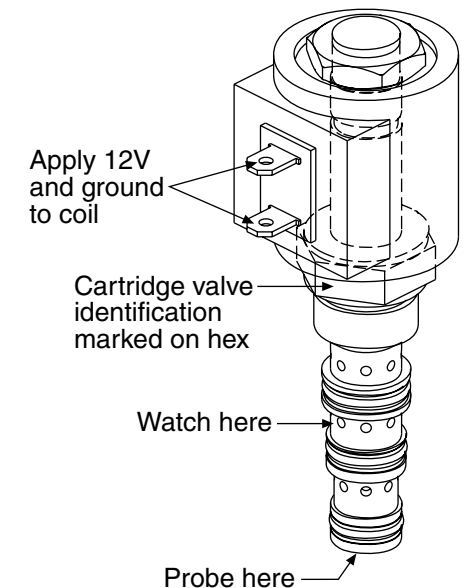

HEADLAMP TEST DIAGRAM – 9-PIN HARNESS ('98 AND OLDER VEHICLES)

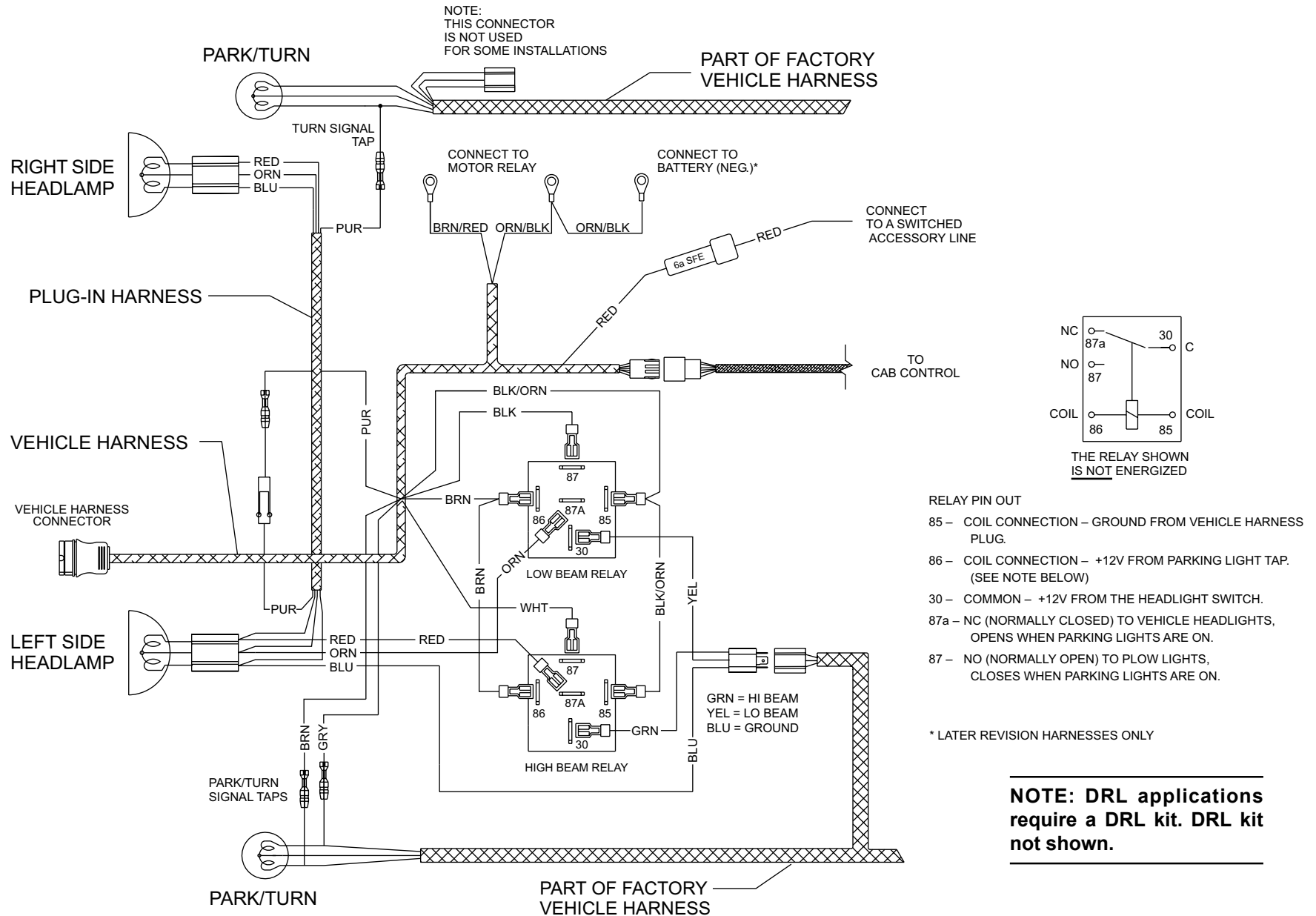

VEHICLE HEADLAMP TEST – 9-PIN HARNESS

1. Verify correct harness and wire installation to relays and vehicle headlamps. See the Headlamp Test Diagram – 9-Pin Harness. The specific wiring diagram for the vehicle can be found in the

plow installation instructions, the WESTERN® UniMount® Service Manual Vol. 2., or (for '98 and older vehicles) the manual [Headlamp Electrical Schematics for Straight Blades](#).

2. Turn ignition and headlight switch on.
3. Disconnect all harnesses at the front of the vehicle.
4. All bulbs must be good.

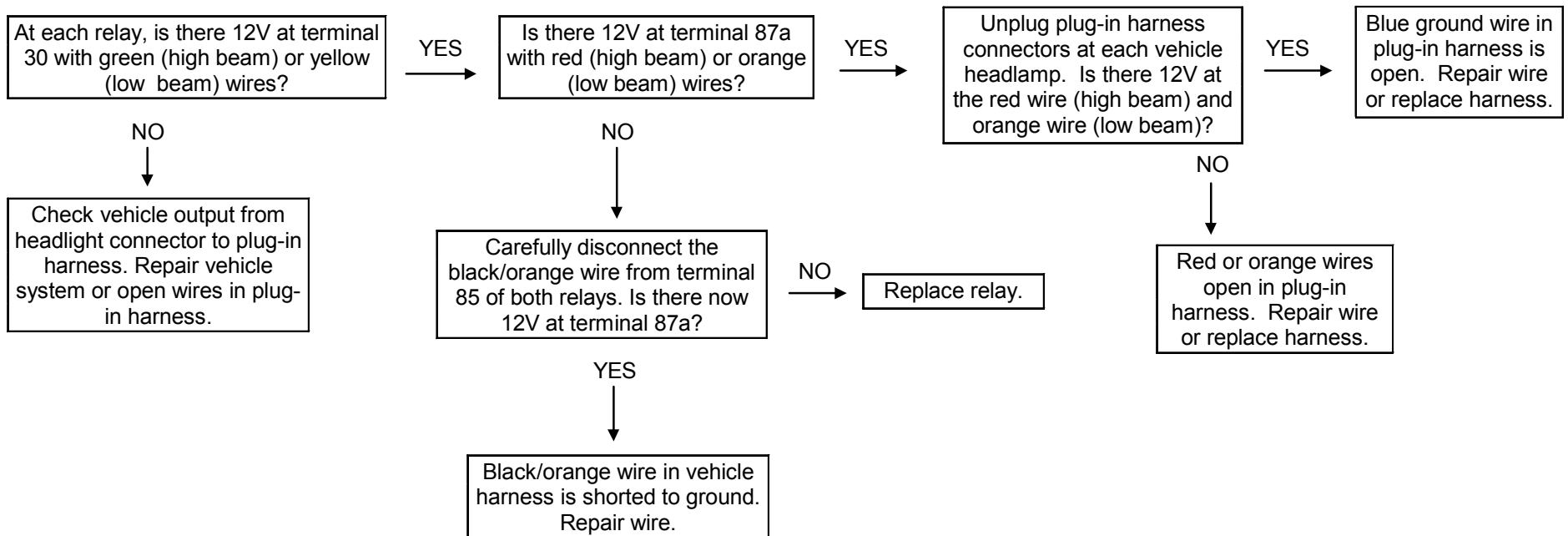

PLOW HEADLAMP TEST – 9-PIN HARNESS

1. Verify correct harness and wire installation to the headlamp relays.
2. All bulbs must be good.
3. Connect all harnesses at the front of the vehicle.

4. Turn vehicle headlamp switch on. For vehicles with Daytime Running Lamps (DRLs), turn ignition on. DRL equipped vehicles have a pink wire instead of a brown wire on relay terminal 86.

5. Refer to the 9-Pin Electrical Schematic Headlamp Test Diagram – 9-Pin Harness, and Connector diagram. The specific wiring diagram for the vehicle can

be found in the plow installation instructions, the WESTERN® UniMount® Service Manual Vol. 2., or (for '98 and older vehicles) the manual Headlamp Electrical Schematics for Straight Blades.

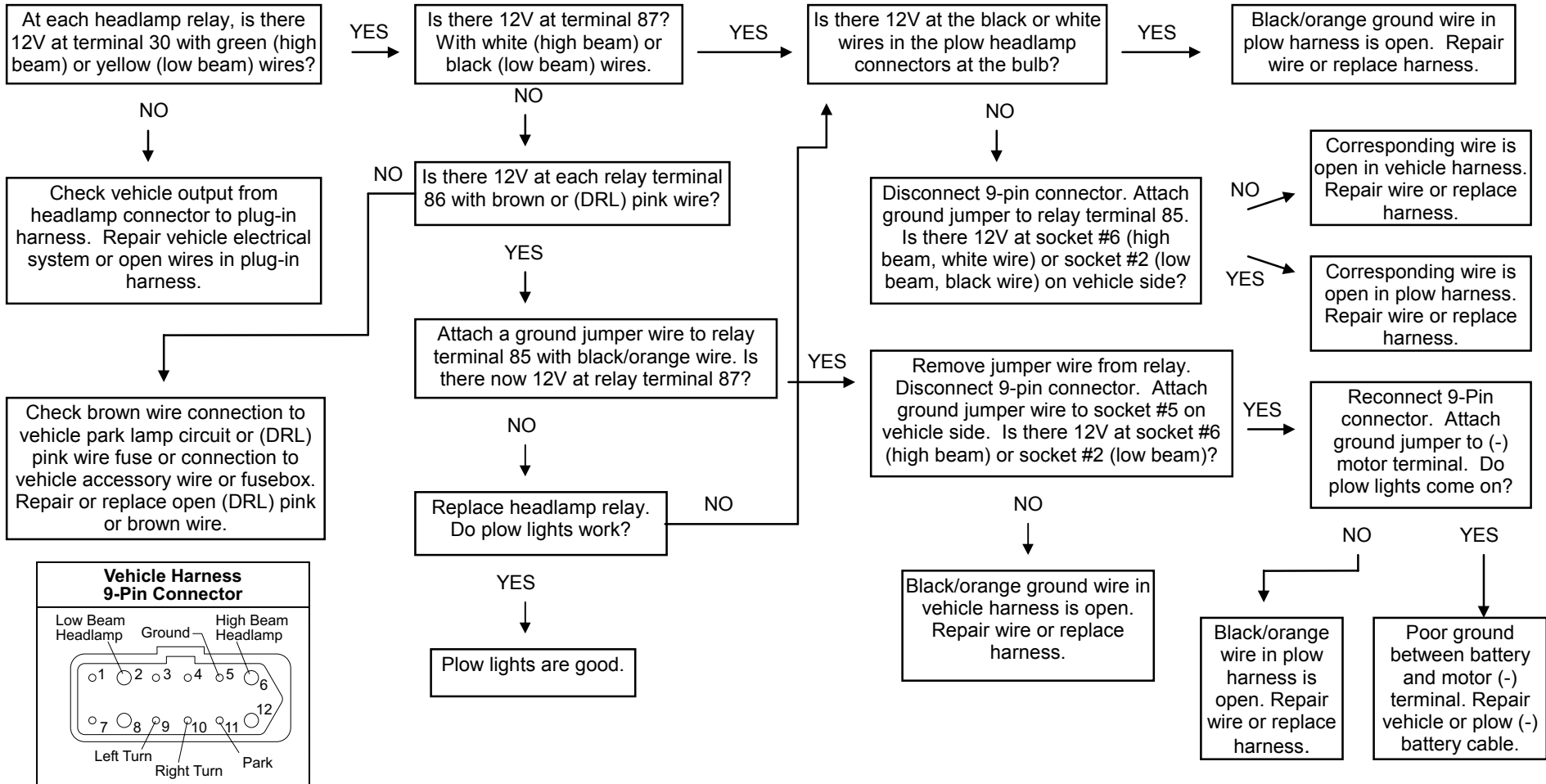

PARK/TURN LAMP TEST – 9-PIN OR 12-PIN HARNESS

1. Verify plow park/turn (P/T) bulbs and contacts are good.
2. Turn parking lamps and ignition on.
3. Connect all harnesses at the front of the vehicle.
4. Refer to the Vehicle Harness 9- or 12-Pin Connector diagram.

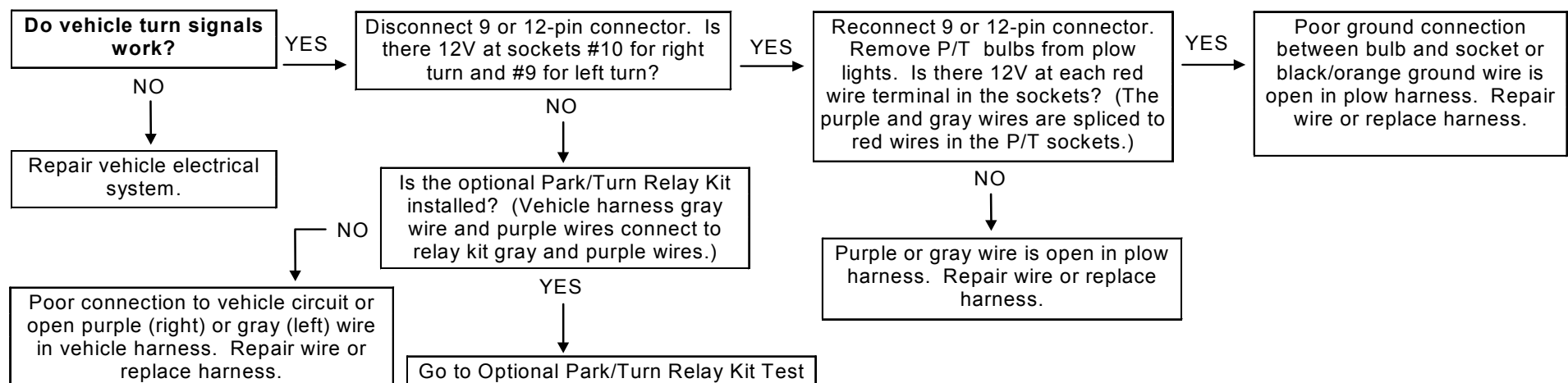
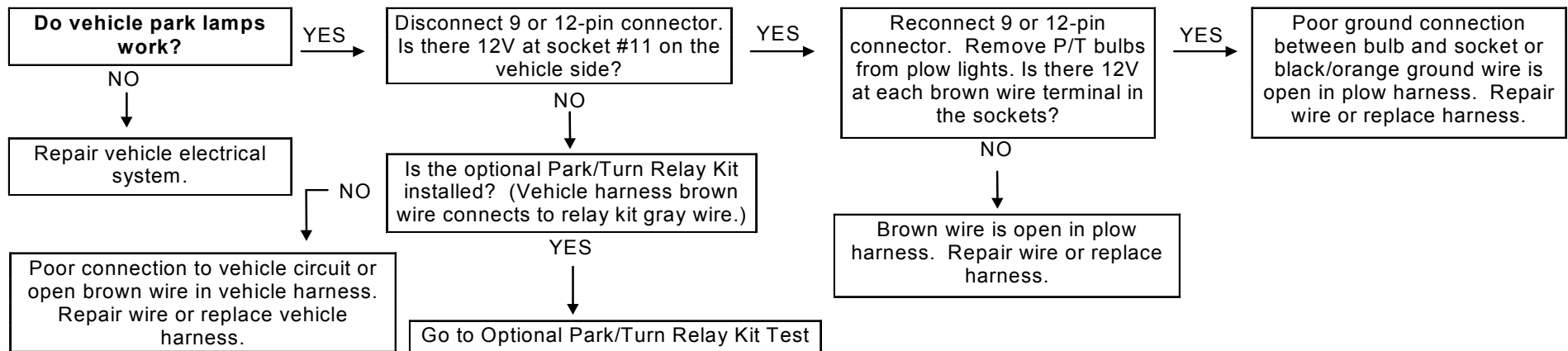
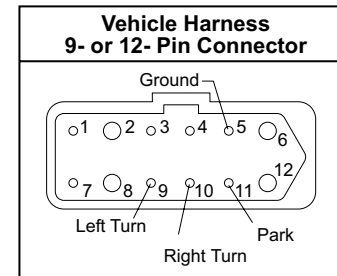

OPTIONAL PARK/TURN RELAY KIT TEST

1. Turn signal applications use both gray and purple relay circuits.
2. Park lamp applications use gray relay circuit only. If gray relay circuit fails, purple relay circuit can be used instead.
3. Refer to the Optional Park/Turn Relay Kit schematic.
4. Verify relay kit red and black wires are connected to battery (+) and (-) respectively.
5. Verify in-line 10 amp fuse in red wire is good.
6. Disconnect long and short gray and purple wires to isolate relay circuits.

Note: If the snowplow park/turn lamps are on when the vehicle park/turn lamps are off, replace the relay kit.

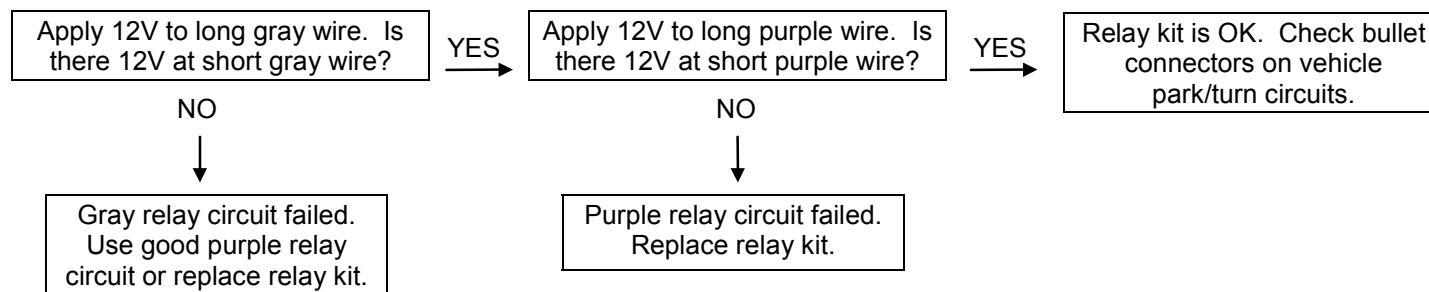

VEHICLE HEADLAMP TEST – 12-PIN HARNESS – 3 RELAY SYSTEM ONLY

1. Verify correct harness and wire installation to headlamp relays, vehicle headlamps, and vehicle headlamp connectors.
2. All bulbs must be good.
3. Disconnect all harnesses at the front of the vehicle.
4. Turn vehicle headlamp switch on. For vehicles with Daytime

Running Lamps (DRL's), turn ignition on. DRL equipped vehicles have a pink wire instead of a brown wire on relay terminal 86.

5. Verify power for both high and low beam and ground are present at the original vehicle headlamp connectors.

6. Refer to the Electrical Schematic – 12-Pin Harness, and the Headlamp Test Diagram – 12-Pin Harness. The specific wiring diagram for the vehicle can be found in the plow installation instructions, the WESTERN® UNIMOUNT® Service Manual Vol.2., or (for '98 and older vehicles) the manual Headlamp Electrical Schematics for Straight Blades.

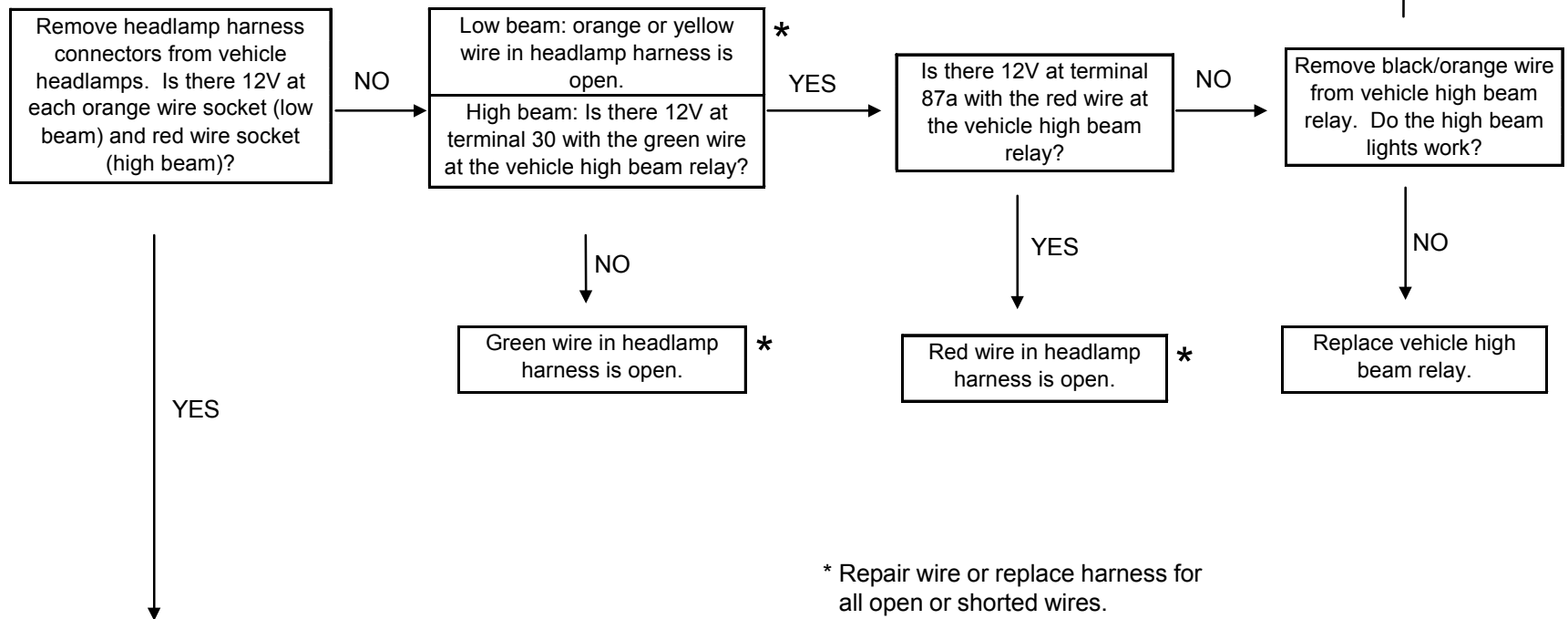

* Repair wire or replace harness for all open or shorted wires.

VEHICLE HEADLAMP TEST – 12-PIN HARNESS – 3 RELAY SYSTEM ONLY

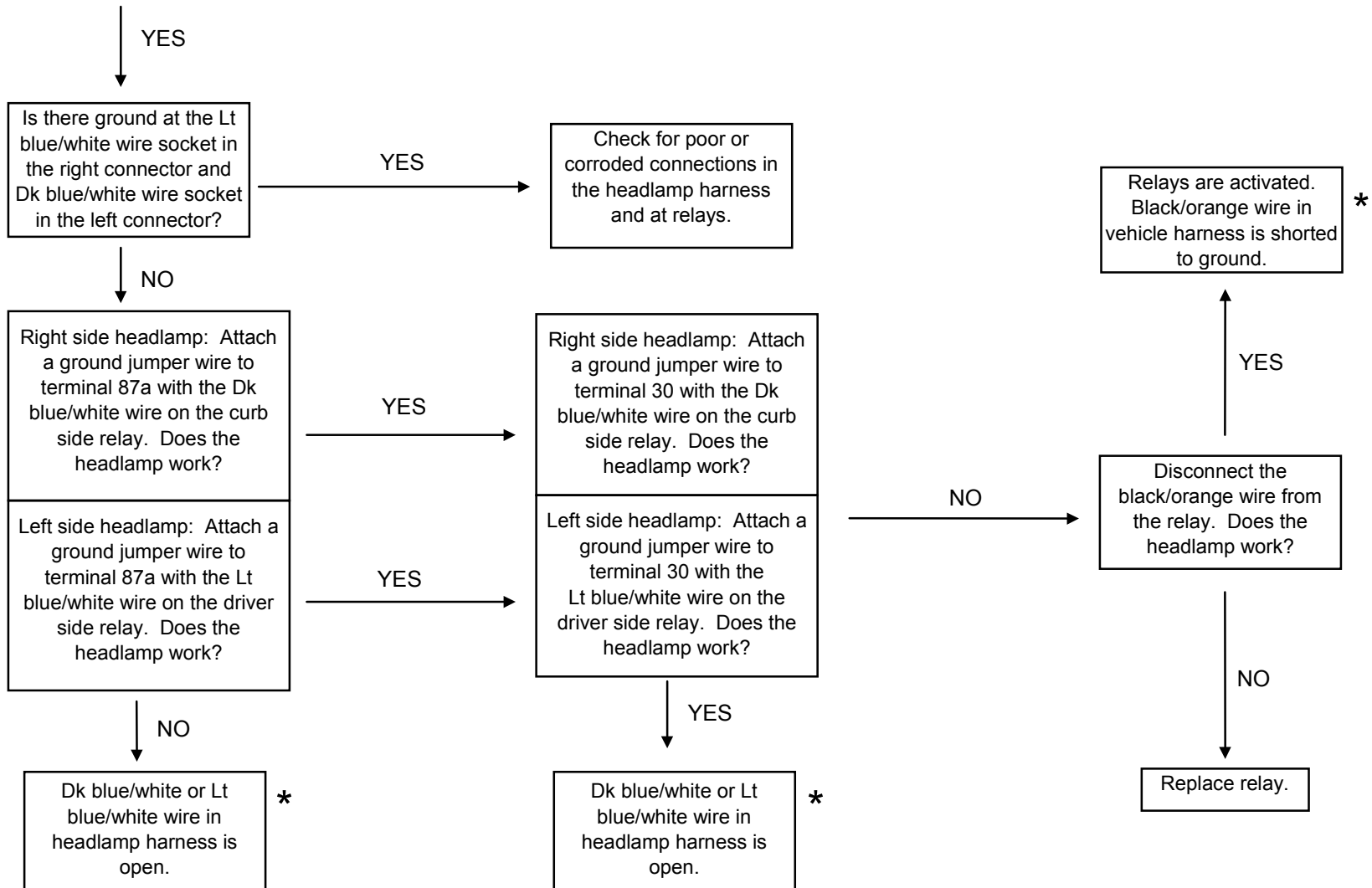

* Repair wire or replace harness for all open or shorted wires.

PLOW HEADLAMP TEST – 12-PIN HARNESS – 3 RELAY SYSTEM ONLY ('98 AND OLDER VEHICLES)

1. Verify correct harness and wire installation to headlamp relays, vehicle headlamps, and vehicle headlamp connectors.
2. All bulbs must be good.
3. Connect all harnesses at the front of the vehicle.

4. Turn vehicle headlamp switch on. For vehicles with Daytime Running Lamps (DRL's), turn ignition on. DRL equipped vehicles have a pink wire instead of a brown wire on relay terminal 86.

5. Verify power for both high and low beam and ground are present at the original vehicle headlamp connectors.
6. Refer to the Electrical Schematic – 12-Pin Harness, and the Headlamp Test Diagram – 12-Pin

Harness. The specific wiring diagram for the vehicle can be found in the plow installation instructions, the WESTERN® UNIMOUNT® Service Manual Vol.2., or (for '98 and older vehicles) the manual [Headlamp Electrical Schematics for Straight Blades](#).

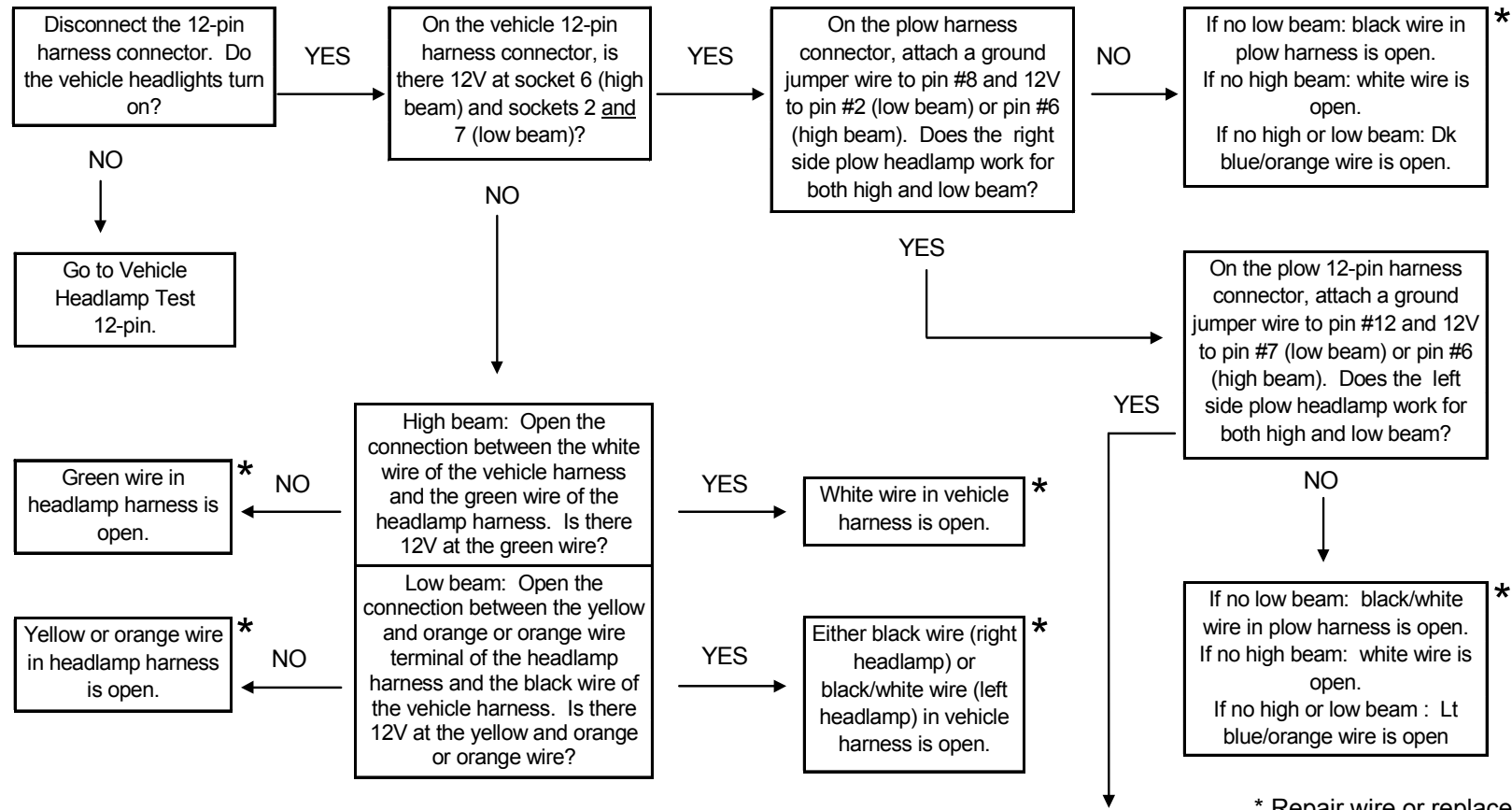

PLOW HEADLAMP TEST – 12-PIN HARNESS – 3 RELAY SYSTEM ONLY ('98 AND OLDER VEHICLES)

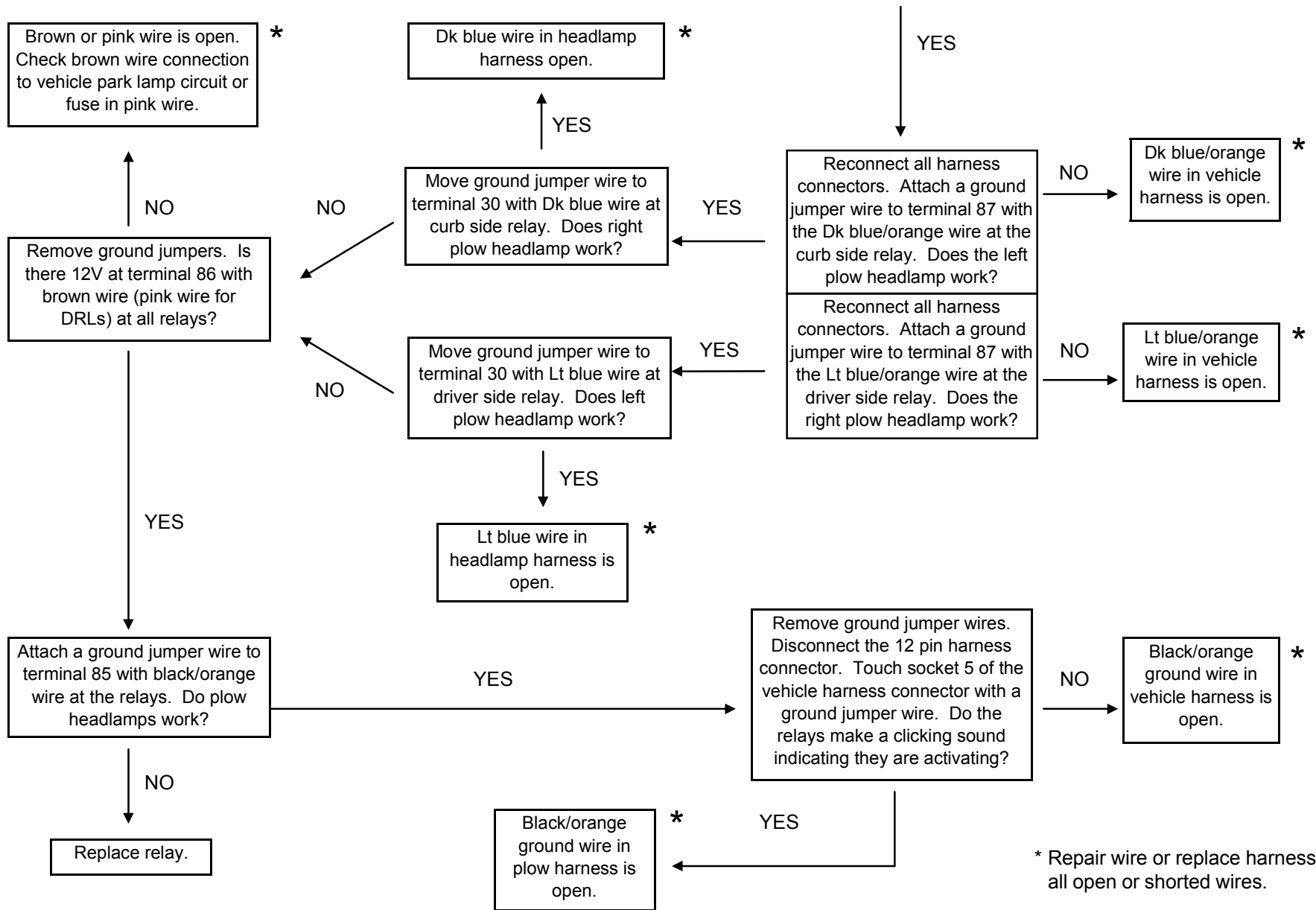

HEADLAMP TEST DIAGRAM – 12-PIN HARNESS – 3 RELAY SYSTEM ONLY ('98 AND OLDER VEHICLES)

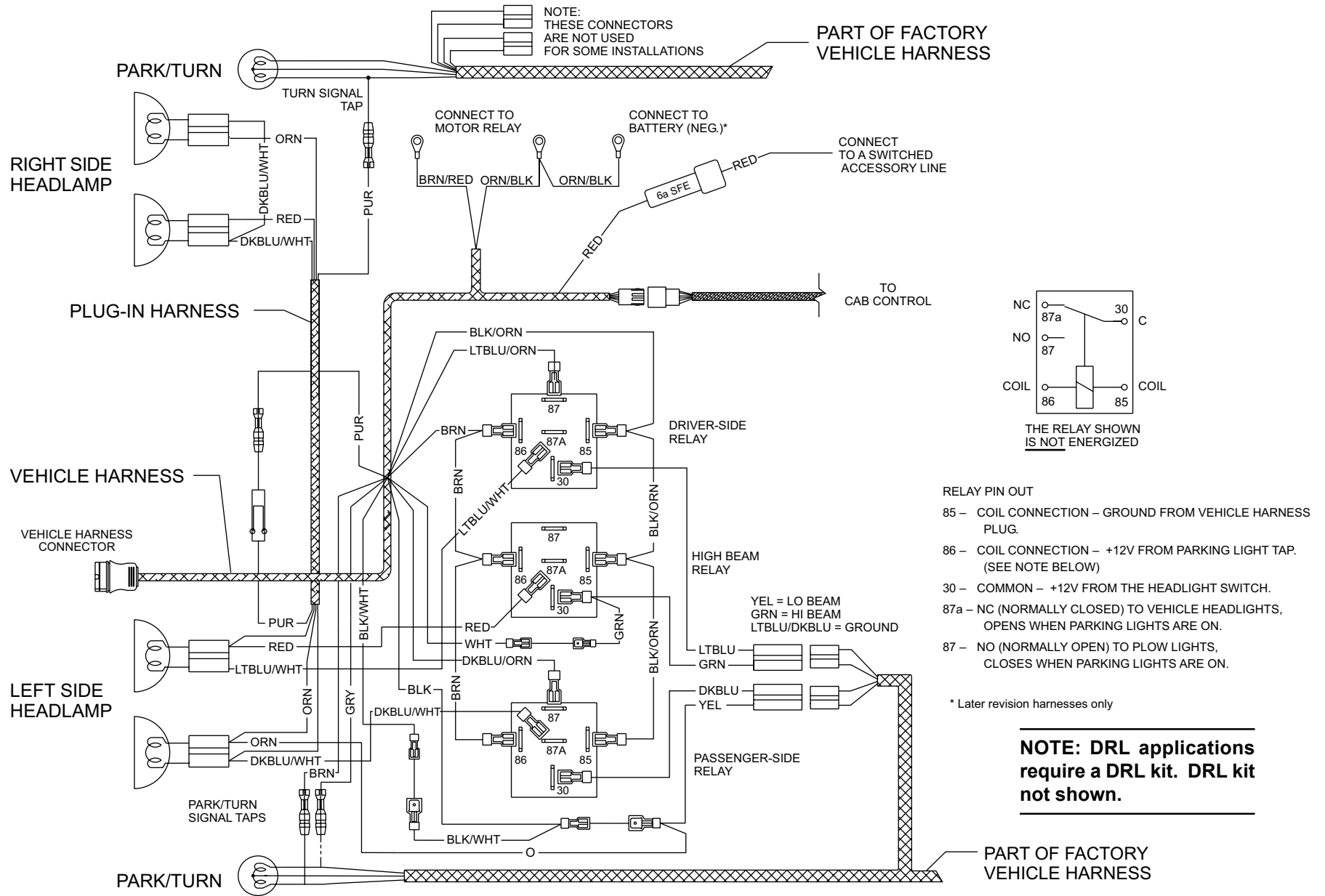

NOTES

NOTES



WESTERN PRODUCTS
7777 NORTH 73RD STREET
P.O. BOX 23045
MILWAUKEE, WISCONSIN 53223



A DIVISION OF DOUGLAS DYNAMICS, L.L.C.

Copyright © 1998 Douglas Dynamics, L.L.C. All rights reserved. This material may not be reproduced or copied, in whole or in part, in any printed, mechanical, electronic, film or other distribution and storage media, without the written consent of Western Products. Authorization to photocopy items for internal or personal use by Western Products outlets is granted.

Western Products reserves the right under its product improvement policy to change construction or design details and furnish equipment when so altered without reference to illustrations or specifications used herein. Western Products and the vehicle manufacturer may require and/or recommend optional equipment for snow removal. This product is manufactured under the following patents: 4,280,062, 4,999,935, 5,125,174, and 5,420,480, and RE35700 with additional patents pending. Western Products offers a limited warranty on all snowplows and accessories. See separately printed page for this important information. The following are registered (®) and unregistered (™) trademarks of Douglas Dynamics, L.L.C.: ISARMATIC®, UniMount®, WESTERN®

Printed in USA