



STANDARD POLY PLOW BLADE ASSEMBLY INSTRUCTIONS

Blade No. 62110

A, Q, & L Box No. 62120
Hydraulics Box No. 56365
Headlamp Kit No. 61540 or 61550

⚠ CAUTION

See your WESTERN® outlet for application recommendations. The Selection List has specific vehicle and snowplow requirements.

TABLE OF CONTENTS

SAFETY	1
Safety Definitions	1
Safety Labels	1
Safety Precautions	1
Personal Safety	2
Fire and Explosion	2
Ventilation	2
Battery Safety	3
Hydraulic Safety	3
Torque Chart	3
ASSEMBLY INSTRUCTIONS	4
Plow Assembly with Poly Blade	4
Assembling Quadrant to Blade	5
Assembling A-Frame to Quadrant	5
Assembling Chain Attachment to A-frame	5
Assembling Stand to A-frame	6
Assembling Lift Frame to A-frame	6
Assembling Lift Channel and Hydraulic Unit to Lift Frame	7
Assembling Hydraulic Fittings and Hoses	7
Assembling Light Brackets and Headlamps	8
Hydraulic Unit Wiring Assembly	8
Battery Cable to Motor Assembly	9
Blade Guide Assembly Installation Instructions	10

SAFETY

SAFETY DEFINITIONS

⚠ WARNING

Indicates a potentially hazardous situation that, if not avoided, could result in death or serious personal injury.

⚠ CAUTION

Indicates a situation that, if not avoided, could result in minor personal injury and/or damage to product or property.

NOTE: Identifies tips, helpful hints and maintenance information the owner/operator should know.

SAFETY LABELS

Become familiar with and inform users about the warning and instruction labels on the back of the blade.

Warning and Caution Label

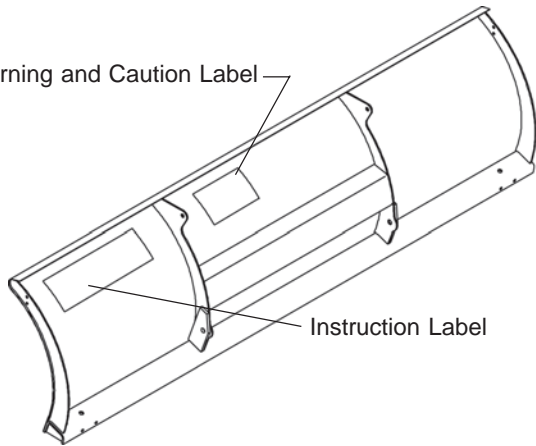

Instruction Label

Instruction Label

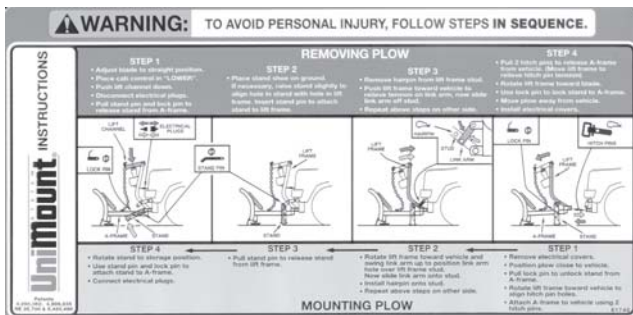

Warning and Caution Label

⚠ WARNING

LOWER BLADE WHEN VEHICLE IS PARKED.
REMOVE BLADE ASSEMBLY BEFORE PLACING VEHICLE ON HOIST.
DO NOT EXCEED GVWR OR GAWR INCLUDING BLADE AND BALLAST.

⚠ CAUTION

READ *OWNER'S MANUAL* BEFORE OPERATING OR SERVICING SNOWPLOW.
TRANSPORT SPEED SHOULD NOT EXCEED 45 MPH. REDUCE SPEED UNDER ADVERSE TRAVEL CONDITIONS.
PLOWING SPEED SHOULD NOT EXCEED 10 MPH.
SEE YOUR WESTERN OUTLET FOR APPLICATION RECOMMENDATIONS.

SAFETY PRECAUTIONS

Improper installation and operation could cause personal injury, and/or equipment and property damage. Read and understand labels and the *Owner's Manual* before installing, operating, or making adjustments.

⚠ WARNING

Lower blade when vehicle is parked. Temperature changes could change hydraulic pressure, causing the blade to drop unexpectedly or damaging hydraulic components. Failure to do this can result in serious personal injury.

⚠ WARNING

Remove blade assembly before placing vehicle on hoist.

⚠ WARNING

Keep well clear of the blade when it is being raised, lowered or angled. Do not stand between the vehicle and blade or directly in front of blade. If the blade hits you or drops on you, you could be seriously injured.

(Continued on next page.)

SAFETY

SAFETY PRECAUTIONS (CONTINUED)

⚠ WARNING

The driver shall keep bystanders clear of the blade when it is being raised, lowered or angled. Do not stand between the vehicle and the blade or within 8 feet of a moving blade. A moving or falling blade could cause personal injury.

⚠ WARNING

Keep hands and feet clear of the blade and A-frame when mounting or removing the snowplow. Moving or falling assemblies could cause personal injury.

⚠ WARNING

Do not exceed GVWR or GAWR including blade and ballast. The rating label is found on driver-side vehicle door cornerpost.

⚠ CAUTION

Refer to the current selection list for minimum vehicle recommendations and ballast requirements.

⚠ CAUTION

To prevent accidental movement of the blade, always turn the ON/OFF switch to OFF whenever the snowplow is not in use. The control indicator light will turn off.

PERSONAL SAFETY

- Wear only snug-fitting clothing while working on your vehicle or snowplow.
- Do not wear jewelry or a necktie, and secure long hair.
- Wear safety goggles to protect your eyes from battery acid, gasoline, dirt and dust.
- Avoid touching hot surfaces such as the engine, radiator, hoses and exhaust pipes.
- Always have a fire extinguisher rated BC handy, for flammable liquids and electrical fires.

FIRE AND EXPLOSION

⚠ WARNING

Gasoline is highly flammable and gasoline vapor is explosive. Never smoke while working on vehicle. Keep all open flames away from gasoline tank and lines. Wipe up any spilled gasoline immediately.

Be careful when using gasoline. Do not use gasoline to clean parts. Store only in approved containers away from sources of heat or flame.

VENTILATION

⚠ WARNING

Vehicle exhaust contains deadly carbon monoxide (CO) gas. Breathing this gas, even in low concentrations, could cause death. Never operate a vehicle in an enclosed area without venting exhaust to the outside.

SAFETY

BATTERY SAFETY

⚠ CAUTION

Batteries normally produce explosive gases which can cause personal injury. Therefore, do not allow flames, sparks or lit tobacco to come near the battery. When charging or working near a battery, always cover your face and protect your eyes, and also provide ventilation.

Batteries contain sulfuric acid which burns skin, eyes and clothing.

Disconnect the battery before removing or replacing any electrical components.

⚠ CAUTION

Always disconnect the battery before removing or replacing electrical components such as a motor relay or battery cable.

HYDRAULIC SAFETY

⚠ WARNING

Hydraulic oil under pressure could cause skin injection injury. If you are injured by hydraulic oil, get medical attention immediately.

⚠ CAUTION



Do not mix different types of hydraulic fluid. Some fluids are not compatible and may cause performance problems and product damage.

- Always inspect hydraulic components and hoses before using. Replace any damaged or worn parts immediately.
- If you suspect a hose leak, DO NOT use your hand to locate it. Use a piece of cardboard or wood.

TORQUE CHART

⚠ CAUTION

Read instructions before assembling. Bolts should be finger tight until instructed to tighten according to the torque chart. Use standard methods and practices when attaching snowplow including wearing safety glasses during cutting, drilling and welding.

Recommended Fastener Torque Chart (Ft.-Lb.)			
Size	 SAE Grade 2	 SAE Grade 5	 SAE Grade 8
1/4-20	6	9	13
5/16-18	11	18	28
3/8-16	19	31	46
3/8-24	24	46	68
7/16-14	30	50	75
1/2-13	45	75	115
9/16-12	66	110	165
5/8-11	93	150	225
3/4-10	150	250	370
7/8-9	202	378	591
1-8	300	583	893

Metric Grade 8.8 (Ft.-Lb.)			
Size	Torque	Size	Torque
M 6	7	M 12	60
M 8	17	M 14	95
M 10	35	M 16	155

These torque values apply to mount assembly fasteners except those noted in the instruction.

ASSEMBLY INSTRUCTIONS

PLOW ASSEMBLY WITH POLY BLADE

⚠ WARNING

To avoid personal injury, follow steps in sequence.

⚠ CAUTION

See your WESTERN® outlet for application recommendations.

IMPORTANT: Read instructions before assembling. Bolts should be finger tight until instructed to tighten. Use standard methods and practices when attaching the snowplow.

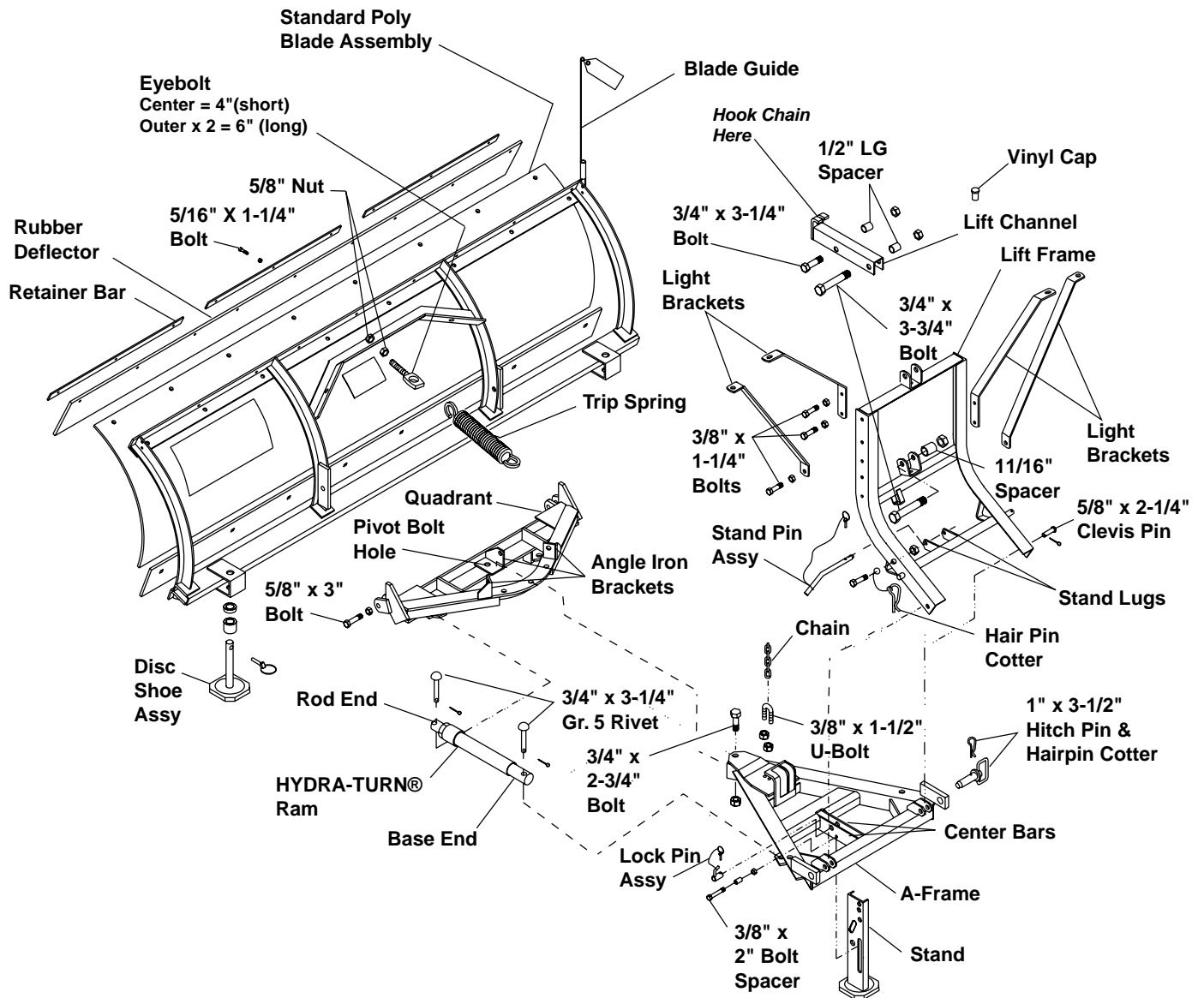

Figure 1

ASSEMBLY INSTRUCTIONS

Assembling Quadrant to Blade

1. Lay the blade face down on cardboard on the floor. Assemble the quadrant to the blade with the quadrant lugs straddling the center ribs. Secure with three 5/8" x 3" bolts and locknuts. **DO NOT bend lugs by overtightening nuts.**
2. Thread one 5/8" nut halfway down on each of two eyebolts. Hook a spring to each of the two angle iron brackets on top of the curved angle of the quadrant. Hook an eyebolt to the other end of each trip spring.
3. Push the threaded ends of the eyebolts through the holes in the top angle of the blade. Install a second nut above the frame.

⚠ CAUTION

Servicing the trip springs without special tools and knowledge could result in personal injury. See your authorized WESTERN® outlet for service.

⚠ CAUTION

Over tightening springs will not increase blade trip force and can damage the springs.

4. Tighten the top nuts until the coils of the trip springs begin to separate (a piece of paper such as this instruction sheet should pass between the second and third coils). Tighten the bottom nut

Assembling A-Frame to Quadrant

1. Position the A-Frame against the quadrant so the center of the straight frame of the quadrant is between the formed nose plate and angle of the A-Frame, and the curved frame of the quadrant is under the retainer bar. (Refer to Figure 1).
2. Place a 3/4" x 2-1/2" bolt down through the hole in the nose plate and secure with a locknut. **DO NOT overtighten**, A-Frame should pivot freely.
3. Insert rod end of each Hydra-Turn® ram into brackets on the bottom of the quadrant. Insert 3/4" x 3-1/2" rivet.

4. Attach base end of each ram (pipe plug facing out) to the side of A-Frame with a 3/4" x 3-1/2" rivet.
5. Insert all rivets from the top and secure with cotter pins.

Assembling Chain Attachment To A-frame

1. Insert the 3/8" x 1-1/2" U-bolt through the end link of the chain.
2. Insert the ends of the U-bolt into the holes in the nose plate of the A-frame and secure with locknuts.

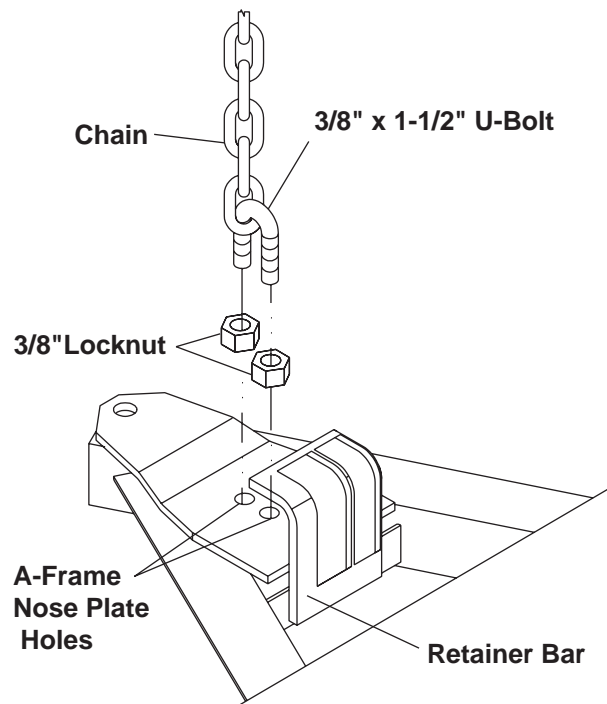

Figure 2

ASSEMBLY INSTRUCTIONS

Assembling Stand To A-frame

If stand is already installed, proceed to Step 5 of this section.

1. Position the stand next to the center bars of the A-frame with the long slot towards the wide end of A-frame.
2. Insert the 9/16" OD spacer into the top end of the long slot in the stand.
3. Holding spacer in place with a finger, insert the stand between the A-frame center bars and align spacer with small hole in center bars.
4. Secure spacer with a 3/8" x 2" bolt and locknut.
5. Hold stand perpendicular to A-frame. Align short slot in stand with large hole in center bars, and insert the lock pin assembly. Secure stand lock pin with a 3/16" linchpin.
6. Tip the plow assembly into plowing position.

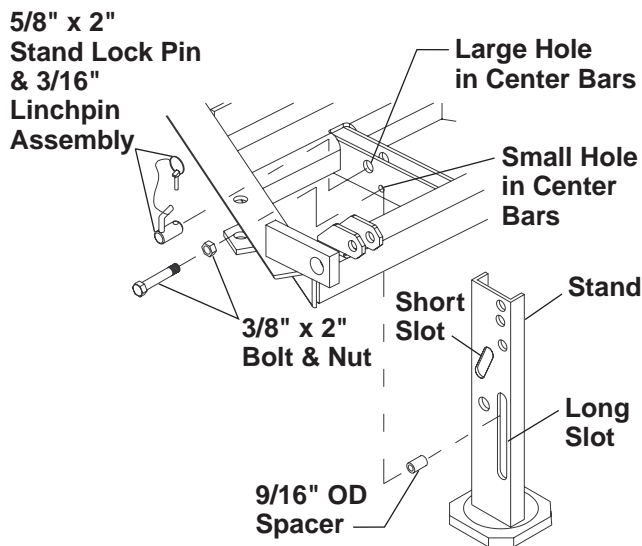

Figure 3

Assembling Lift Frame To A-frame

1. Lay lift frame on floor with curve up and ends of side angles positioned next to wide end of A-frame. Raise end of lift frame and align holes in side angles between inner pairs of lugs on wide end of A-frame.
2. Secure lift frame to A-frame lugs with two 5/8" x 2-1/4" clevis pins inserted from the outside towards the center of the A-frame. Secure with cotter pins.
3. Rotate lift frame to align holes in stand lugs to bottom hole of three hole pattern in top of stand. Secure with a stand pin assembly and 3/16" linchpin.
4. Assemble a hairpin cotter through one eyelet of the 6" lanyard. Attach the other end to the hole in the lift frame located above the stacking stop bracket using the 1/4" flange bolt and nut.

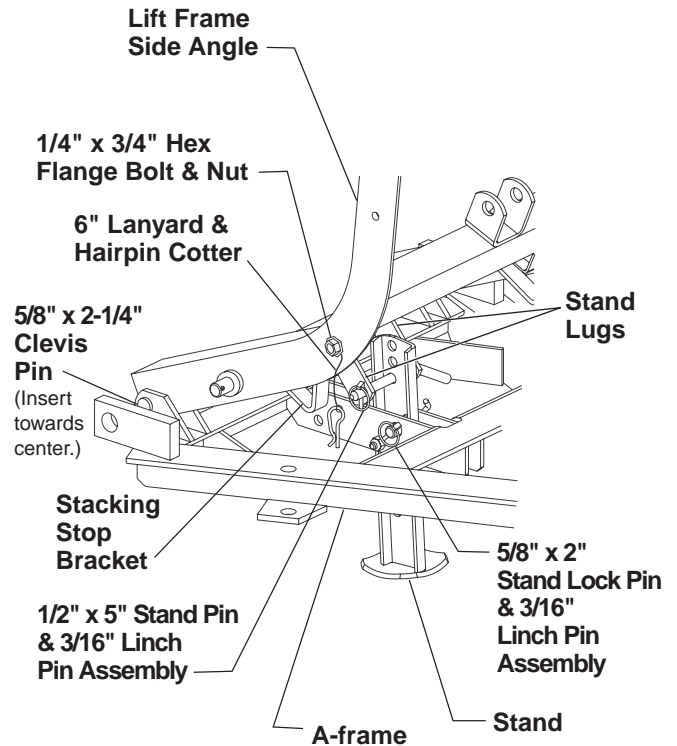

Figure 4

ASSEMBLY INSTRUCTIONS

Assembling Lift Channel and Hydraulic Unit To Lift Frame

1. Place the hole end of the lift channel between the lugs of the upper U-bracket on the lift frame. Insert a 3/4" x 3-3/4" bolt and slide a .50" long spacer over the end of bolt and secure with a jam locknut. **DO NOT OVERTIGHTEN** - lift channel must pivot freely.
2. Position the hydraulic unit (found in hydraulics box), with the nameplate towards the blade and the base lug between the lugs of the lower bracket on the lift frame. Attach with a 3/4" x 3-3/4" bolt, a .69" long spacer, and a jam locknut. **DO NOT OVERTIGHTEN** - hydraulic unit must pivot freely.

⚠ CAUTION

Never use a finger to check an alignment. If the snowplow moves, your finger could be crushed.

3. Align hole in hydraulic unit lift ram with hole near hook on lift channel and attach with a 3/4" x 3-1/4" bolt, a .50" long spacer, and a jam locknut. **DO NOT OVERTIGHTEN** - lift channel must pivot freely.
4. Place second link of chain into hook of lift channel. (Final chain adjustment will be made after plow is mounted on vehicle.)

Assembling Hydraulic Fittings and Hoses

1. (Hoses and fittings are in the hydraulics box.) Remove top two 1/4" pipe plugs from front face of valve on hydraulic unit. Install two 45° swivel fittings into pipe plug holes. Tighten fittings so the hose connections will be straight down in line with valve body. **(See Figure 5.)**
2. Install a 1/4" street elbow into the threaded port in base end of each Hydra-Turn® ram. Tighten fittings so they are oriented 45° from vertical towards the blade. **(See Figure 5.)**
3. Install a hose into the street elbow on each Hydra-Turn ram. Tighten each hose.
4. Route both hoses in front of lift frame and from passenger side to driver side through hose loop on middle cross angle of lift frame.
5. Attach hoses to 45° swivel fitting on hydraulic unit as follows:
 - Passenger side hose to rear 45° swivel fitting.
 - Driver side hose to front 45° swivel fitting.
6. Remove twists from both hoses and tighten swivel connections.

DO NOT use pipe tape/sealant when connecting hoses to swivel fittings.

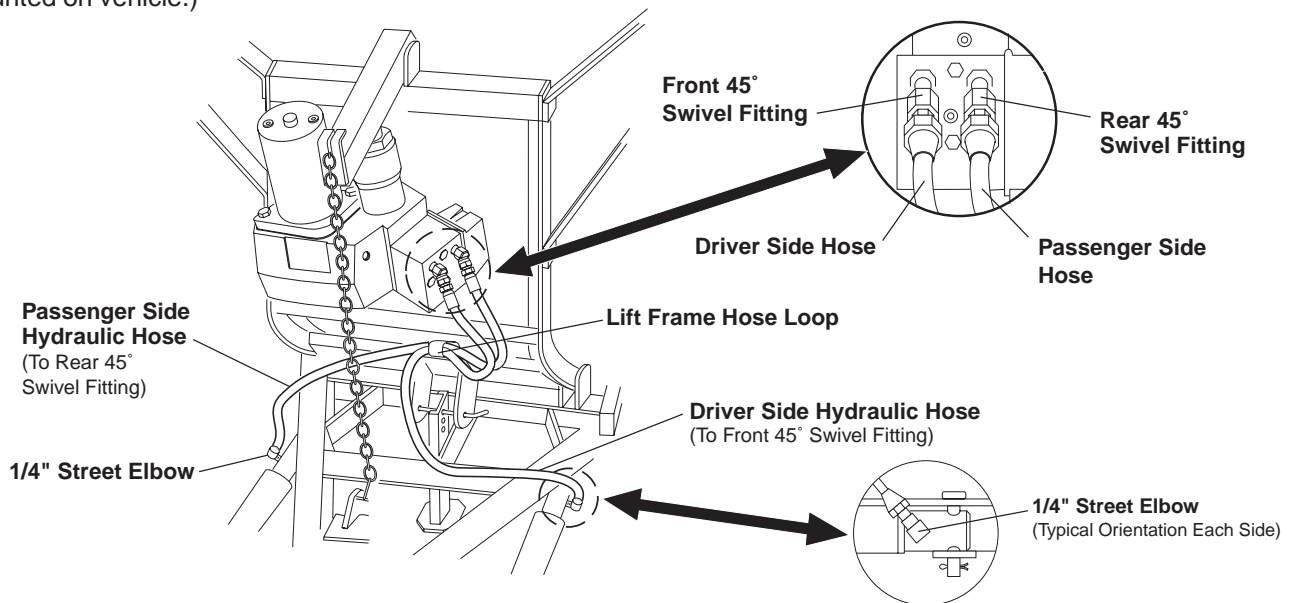

Figure 5
Hydraulic Fitting Orientation and Hose Routing

ASSEMBLY INSTRUCTIONS

Assembling Light Brackets and Headlamps

1. Align two holes of two top light brackets with the top two holes in lift frame side angles. Loosely attach with two 3/8" x 1-1/4" bolts and locknuts on each side.
2. Loosely attach the small hole end of each bottom light bracket to the lowest hole in each lift frame side angle with a 3/8" x 1-1/4" bolt and locknut on each side.
3. Assemble headlamps (found in headlamp kit) to the light brackets, placing the headlamp swivel above the bracket. Loosely attach with lock washers and nuts below the brackets.
Aim headlamps when plow is attached to vehicle.
4. Tighten bolts holding light brackets to lift frame.
5. Install vinyl caps on headlamp mounting studs.

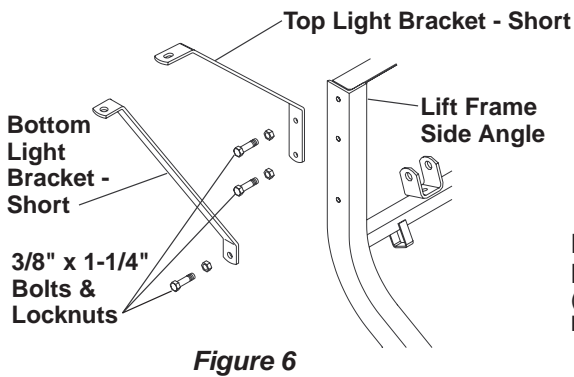
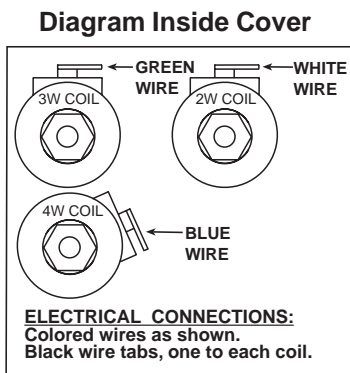

Figure 6



Hydraulic Unit Wiring Assembly

1. Route wiring harness from headlamps along top light brackets and across back of lift frame to driver side of lift frame. Use any excess harness to make a loop under each headlamp. Secure harness to each light bracket with two short cable tie and to top angle of lift frame with a long cable tie.
2. Remove cover from valve manifold on hydraulic unit. Route branch of harness with loose wires to manifold. Apply dielectric grease (P.N. 56099, furnished in hydraulics box) into the opening of each wire terminal before connecting to coil terminals as shown on label inside of cover.

NOTE: Dielectric grease has been applied to coil terminals. DO NOT wipe off terminals.

3. With harness strain relief inside cover at slot and black/orange wire outside of cover, replace cover and secure with screws.
4. While allowing slack in harness to hydraulic unit, secure harness to inside of lift frame side rail with two long cable ties.

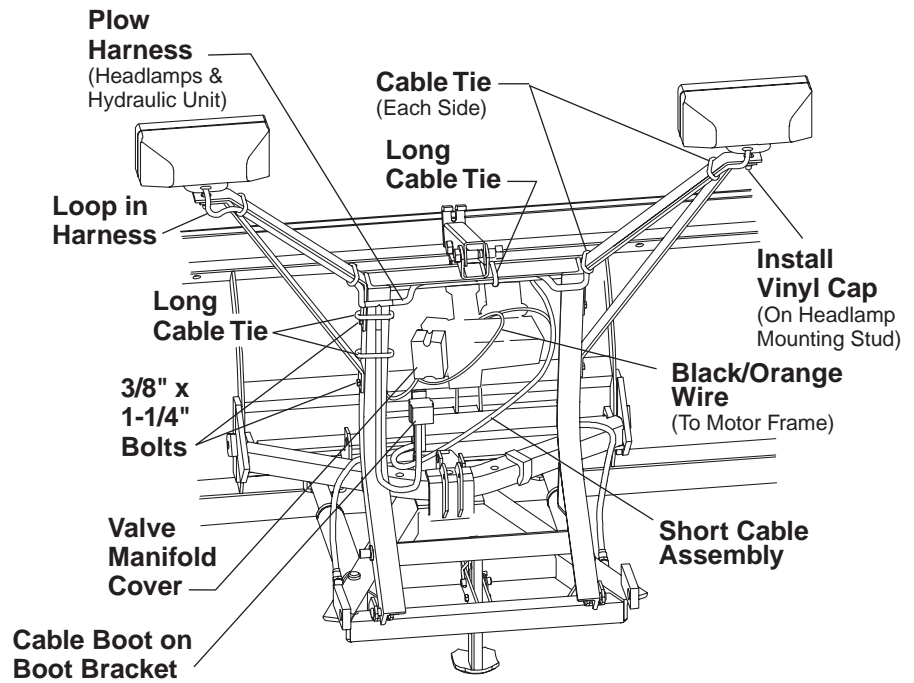

Figure 7

ASSEMBLY INSTRUCTIONS

Battery Cable To Motor Assembly

Apply a light coating of dielectric grease to connectors before assembly.

NOTE: Retain dielectric grease tube for use during vehicle mount installation. Pass tube on to end user.

All parts installed in this section are found in the hydraulics box.

1. Attach black/red battery cable to motor terminal on hydraulic unit. Secure nut to 50-60 in. lbs.
2. Attach black battery cable (without a stripe) and the black/orange wire from under the valve manifold cover to the ground stud. Secure nut to 50-60 in. lbs.

3. Slide small pocket of cable boot onto vertical tab of boot bracket. Insert harness plugs into boot for storage when plow is removed from vehicle.

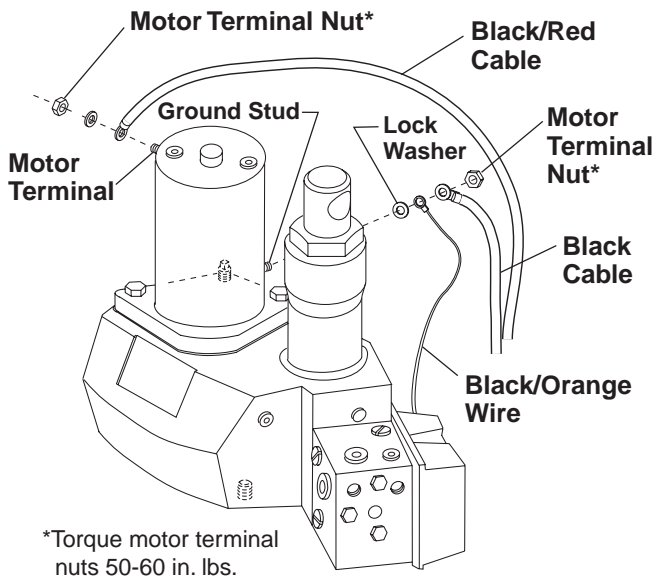

Figure 8

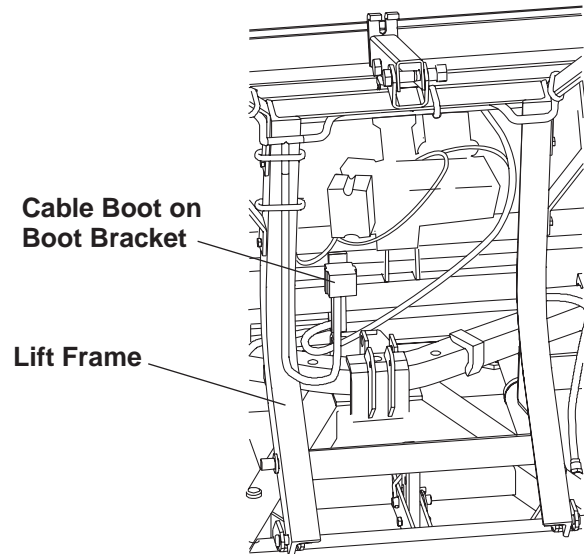

Figure 9

ASSEMBLY INSTRUCTIONS

BLADE GUIDE ASSEMBLY INSTALLATION INSTRUCTIONS

Insert pointed end of clamp into coil of the blade guide rod. Attach a blade guide rod to each outer rib using 5/16" x 1" cap screws and locknuts as shown in Figure 11.

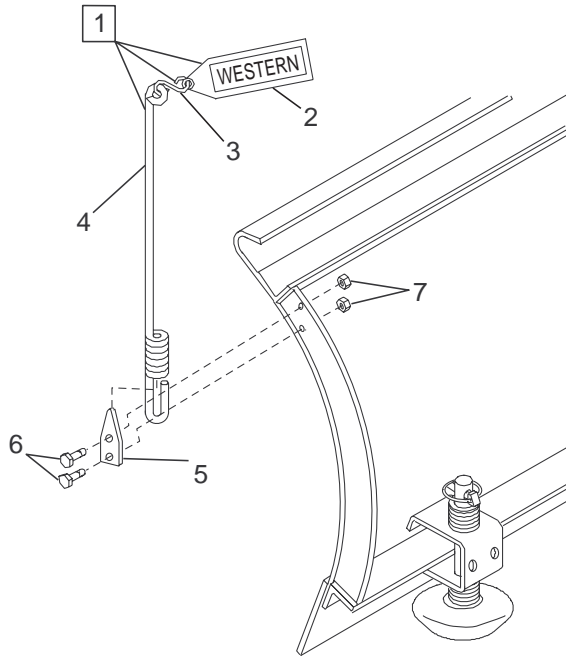

Figure 10

PARTS LIST 59700 — BLADE GUIDE ASSEMBLY

ITEM	PART NO.	QTY.	DESCRIPTION
1	59697	2	BLADE GUIDE ROD, S-HOOK & FLAG
2	. 59694K	1	BLADE GUIDE FLAG
3	. 59696	1	S-HOOK
4	. 59691	1	BLADE GUIDE ROD
5	59946	2	CLAMP
6	90020	4	5/16-18X1 HX CS G2 ZP
7	91332	4	5/16-18 PT HX LK NUT NYIS ZP

Abbreviations

CS	Cap Screw
G	Grade
HX	Hex
LK	Lock
NYIS	Nylon Insert
PT	Prevailing Torque
ZP	Zinc Plate



WESTERN PRODUCTS
P.O. BOX 245038
MILWAUKEE, WI 53224-9538



A DIVISION OF DOUGLAS DYNAMICS, L.L.C.

Western Products reserves the right under its Product Improvement Policy to change construction or design details and furnish equipment when so altered without reference to illustrations or specifications used herein. Western Products and the vehicle manufacturer may require and/or recommend optional equipment for snow removal. Western Products offers a limited warranty on the snowplows and accessories. See separately printed page for this important information. The following are registered® trademarks of Douglas Dynamics, L.L.C.: HYDRATURN®, UNIMOUNT®, and WESTERN®.