

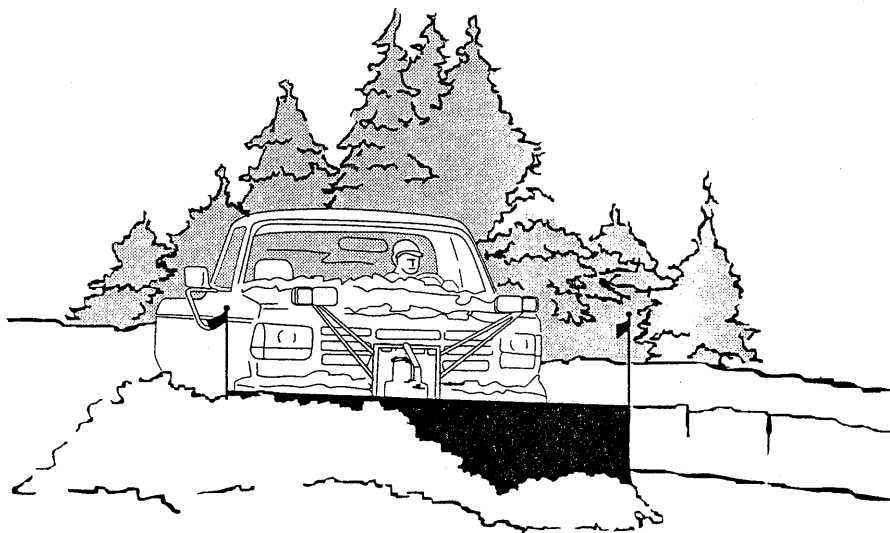

Mechanic's Guide

Cable ISARMATIC®
Hydraulic SYSTEM





Western Products

P.O. Box 245038
Milwaukee, Wisconsin 53224-9538

Division of Douglas Dynamics, Inc.

Western reserves the right under its product improvement procedures to change construction or design details and furnish equipment when so altered without reference to illustrations or specifications used herein. The following are registered® and unregistered™ Trade Marks of Douglas Dynamics, Inc.:

WESTERN®

ISARMATIC®

Hydra-Turn®

Roll-Action®

UniMount®

Western and the vehicle manufacturer may require and/or recommend optional equipment for snow removal. See Western's installation instructions for details. Western offers a one-year limited warranty for all snowplows and accessories. See separately printed page for this important information.

ISARMATIC® Mark IIIa - Cable

1 - Safety Rules

Before You Begin	1-1
Personal Safety	1-1
Ventilation	1-1
Fire and Explosion	1-1
Battery Safety	1-1
Hydraulic Safety	1-2

2 - Plow Tune-Up and Inspection

Pre-service Preparation	2-1
Blade	2-1
A-Frame and Quadrant	2-2
Lift Mount	2-3
Hydraulics	2-4
Electrical	2-6
Snowplow Accessories	2-7

3 - Description of Major Components

Components	3-1
Theory of Operation	3-4

4 - Troubleshooting Section

Troubleshooting Guide	4-1
Hydraulic Unit - Part Reference	4-2
A. Pump Pressure Test	4-2
B. Relay Test	4-3
C. Cushion Valve Adjustment	4-4
D. 3-Way Valve Lever Travel	4-5
E. 4-Way (Angle) Valve Lever Travel and Adjustment	4-5
F. 3-Way (Raise/Lower) Valve Adjustment	4-6
F1. Lift Valve Adjustment	4-7
F2. Check Valve Adjustment	4-7

5 - Breakdown and Reassembly

Repair	5-1
Warranty Repair	5-1
Reference Guide With Photos	5-2

Safety Rules

Before You Begin



WARNING: Read all instructions, including safety information, before performing any service or maintenance on your snowplow.

S 1-01

1. Park the vehicle on a level surface. Place shift lever in PARK or NEUTRAL, and set parking brake.
2. For most service procedures, leave the hydraulic components on the vehicle.

Personal Safety



WARNING: Keep well clear of the blade when it is being raised, lowered, or angled. Do not stand between the vehicle and blade, or directly in front of the blade. If the blade hits you or drops on you, you could be seriously injured.

S 1-02

1. Wear only snug-fitting clothing while working on your vehicle or snowplow. Do not wear jewelry or a necktie. Secure long hair. Be especially careful near moving parts such as fan blades, pulleys, and belts.
2. Wear safety goggles to protect your eyes from battery acid, gasoline, and dust and dirt from machinery.
3. Avoid touching hot surfaces, such as engine, radiator, exhaust pipes, and hoses.
4. Always have a fire extinguisher rated for flammable liquids and electrical fires (rated BC) handy.

Ventilation



WARNING: Vehicle exhaust contains deadly carbon monoxide (CO) gas. Breathing this gas, even in low concentrations, can cause death. Never operate vehicle in an enclosed area without venting exhaust to the outside.

S 1-03

If you work on your vehicle or plow in a garage or other enclosed area, be sure to vent exhaust gas directly to the outside through a leakproof exhaust hose.

Fire and Explosion



WARNING: Gasoline is highly flammable and gasoline vapor is explosive. Never smoke while working on vehicle. Keep all open flames away from gasoline tank and lines. Wipe up any spilled gasoline immediately.

S 1-04

Be extremely careful when using gasoline. Do not use gasoline to clean parts. Store only in approved containers away from sources of heat or flame.

Battery Safety



WARNING: A charging battery gives off gases that can explode if touched by a spark or flame. Cover top of battery with electrically non-conductive material to keep sparks from testing operations away from the battery gases.

S 1-05

1. Never lay tools or equipment on the battery. You could accidentally ground the POSITIVE (+) battery terminal, resulting in electrical shock or burns or damage to the vehicle or equipment.
2. Avoid contact with battery acid. It can burn your eyes or skin, and burn holes in clothing.
3. Always disconnect the battery ground before removing or replacing electrical components, such as the motor relay or battery cables.

ISARMATIC® Mark IIIa - Cable

Hydraulic Safety



WARNING: Hydraulic oil under pressure can cause skin injection injury. If left untreated, these injuries can result in amputation or death. If you are injured by hydraulic oil, get medical treatment immediately.

S 1-06

1. Always inspect hydraulic components and hoses before use. Replace any damaged or worn parts immediately.
2. If you suspect a hose leak, DO NOT use your hand to locate it. Use a piece of cardboard or wood.

Plow Tune-Up and Inspection

This section covers tune-up and inspection procedures for the:

- Pre-service Preparation
- Blade
- A-Frame and Quadrant
- Lift-Mount
- Hydraulics
- Electrical
- Snowplow Accessories

Pre-service Preparation

Servicing the vehicle on a hoist

- Remove the snowplow assembly prior to raising the vehicle on a hoist.

Servicing the vehicle on the ground

- Park the vehicle on a level surface.
- Place the shift lever in PARK or NEUTRAL and engage the parking break.
- When leaving a parked vehicle, always rest the blade firmly on the ground.

Blade

WELDS AND MATERIALS

Inspect all welds and materials for cracks and yielding. Repair or replace as necessary.

DISC SHOES

1. Engage the vehicle's parking brake prior to adjusting the disc shoes.
2. Raise blade and support on blocks
3. Remove the linch pin.

4. Reposition the stacked washers to provide 1/4" to 1/2" clearance between the cutting edge and the ground.
5. Reinstall the linch pin.

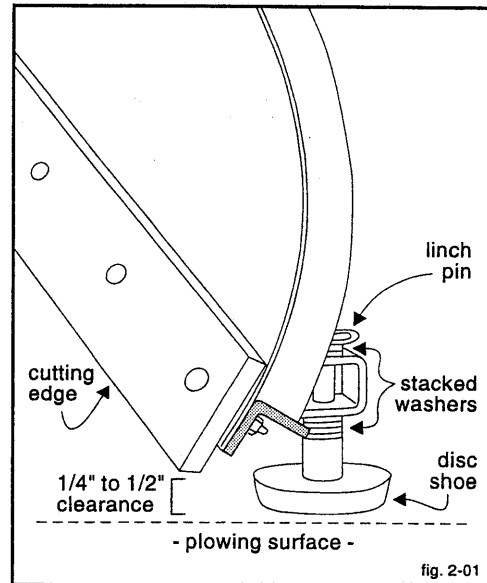

fig. 2-01

TRIP SPRING TENSIONING

Outboard Springs: Tighten outboard trip springs until coils just begin to separate.

Center Springs (if so equipped): Tighten center springs until slack is removed.

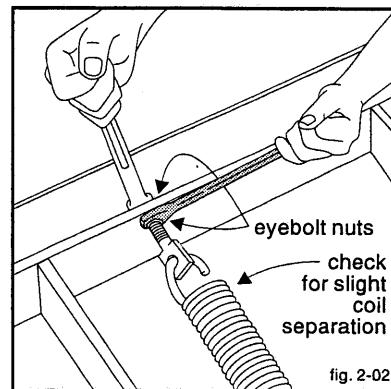

fig. 2-02

STEEL CUTTING EDGES

- Inspect all fasteners for proper torque as specified on the Torque Chart (fig. 2-07).
- Replace fractured or excessively worn cutting edge.

A-Frame and Quadrant

WELDS AND MATERIALS

Inspect all welds and materials for cracks and yielding. Repair or replace as necessary.

PIVOT BOLT ADJUSTMENT

There are variations of pivot bolt assemblies. All require the pivot bolt to be tightened until the A-Frame cannot move, then backed off until the quadrant just begins to swing freely.

The differences are as follows:

- **Pro-Plow Models:** Tighten the first jam nut and pivot bolt. If a weld nut is present, tighten the pivot bolt.
- **Standard Model:** Other assemblies have a pivot bolt and nylock nut.

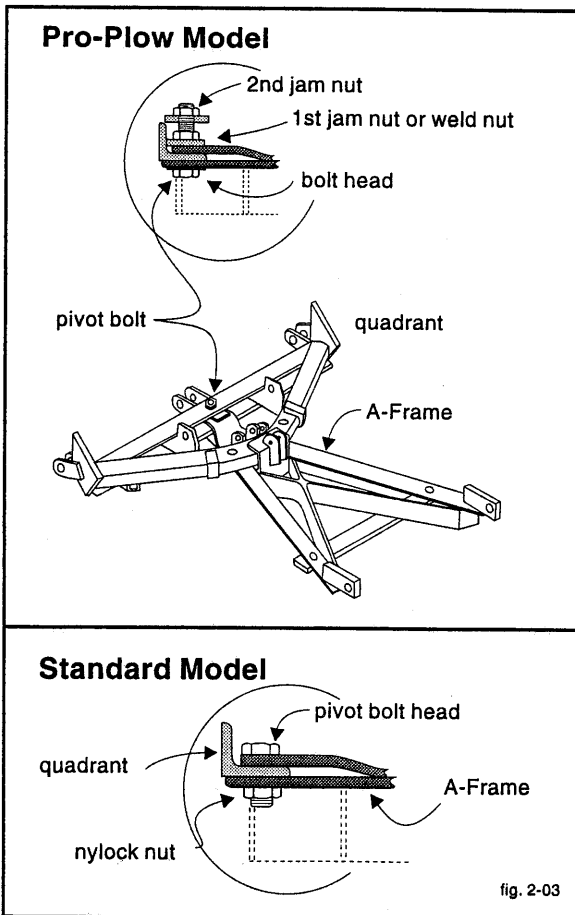

ANGLE STOPS

When the quadrant is rotated, the angle stops must come in contact with the retainer bar on the A-Frame.

- Rebuild the angle stops with extra material if contact isn't being made.

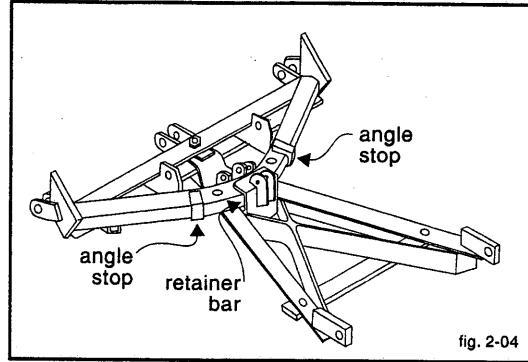

CHAIN BOLT

1. Check the chain bolt for tightness, yielding, and/or cracks.
2. Replace worn chain bolt with WESTERN® #90045 grade 8 bolt.

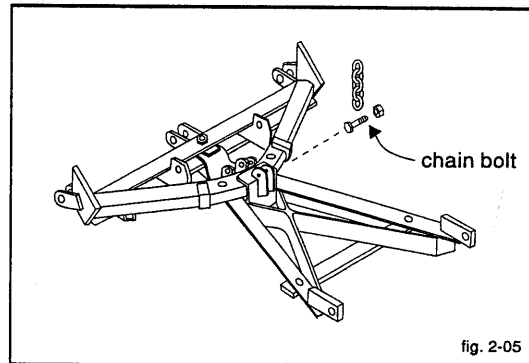

COUPLING LUG ADJUSTMENT

Short A-Frame only: Use the coupling hole on the short A-Frame ear that keeps the short A-Frame parallel to the ground.

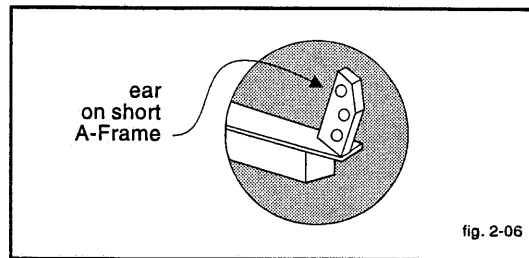

Lift Mount

WELDS AND MATERIALS

Inspect all welds and materials for cracks and yielding. Repair or replace as necessary.

FASTENERS

1. Inspect all fasteners for tightness and wear.
2. Replace damaged fasteners. Torque all fasteners to the values on the Torque Chart below.

Torque Chart			
Size	Torque in Foot Pounds		
	Grade 2	Grade 5	Grade 8
1/4 - 20	6	9	13
5/16 - 18	11	18	28
3/8 - 16	19	31	46
3/8 - 24	24	46	68
7/16 - 14	30	50	75
1/2 - 13	45	75	115
9/16 - 12	66	110	165
5/8 - 11	93	150	225
3/4 - 10	150	250	370
7/8 - 9	202	378	591
1 - 8	300	583	893

Metric Grade 8.8		Torque in Foot Pounds	
M 6	7	M 12	60
M 8	17	M 14	95
M 10	35	M 16	155

These torque values apply to lift-mount fasteners except those noted in the instructions where motion is desired.

fig. 2-07

COUPLING LUG HEIGHT

With the blade assembly attached, the coupling lug must be between 9-1/2" and 10-1/2" from ground level to the center of the coupling hole in order to keep the A-Frame parallel to the ground.

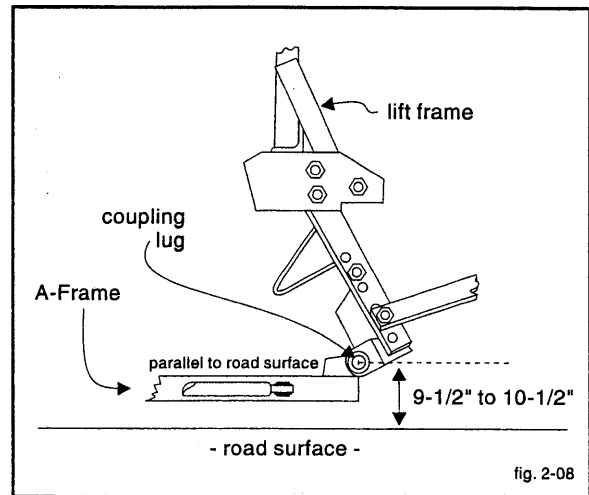

fig. 2-08

LIFTING CHAIN

Inspect the lifting chain slack to determine whether the snowplow can float (rise and fall) with the contour of the plowing surface.

1. Lower the blade.
2. Fully collapse the lift channel.
3. Pull chain tight and insert in slot.
4. Check: There should be at least two links of slack when the Illa control is in a neutral position and the lift channel is fully collapsed.

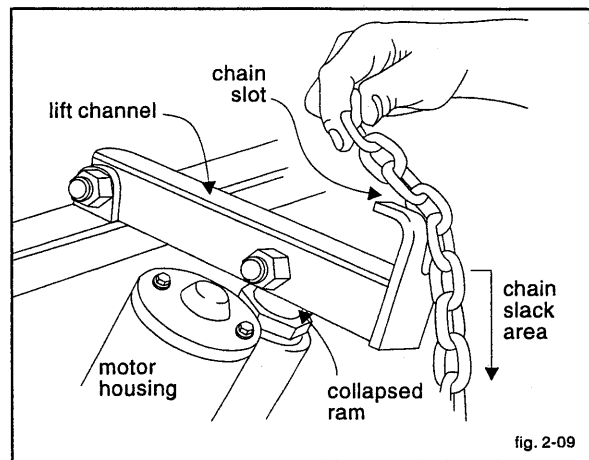

fig. 2-09

ISARMATIC® Mark IIIa - Cable

Hydraulics

FLUID SPECIFICATIONS



CAUTION: Never mix different types of oil. Mixed oil can damage the hydraulic component.

S 2-10

Use new automatic transmission fluid (ATF) such as Dexron III to -10° F (-23° C) or WESTERN® High Performance Fluid to -25° F (-32° C). Texaco 1537 Aircraft Hydraulic Oil should be used for temperatures below -25° F (-32° C).

OIL LEVEL

1. Push lift channel completely down, fully collapsing the lift ram.
2. Fill reservoir to the filler hole threads and replace the filler plug.

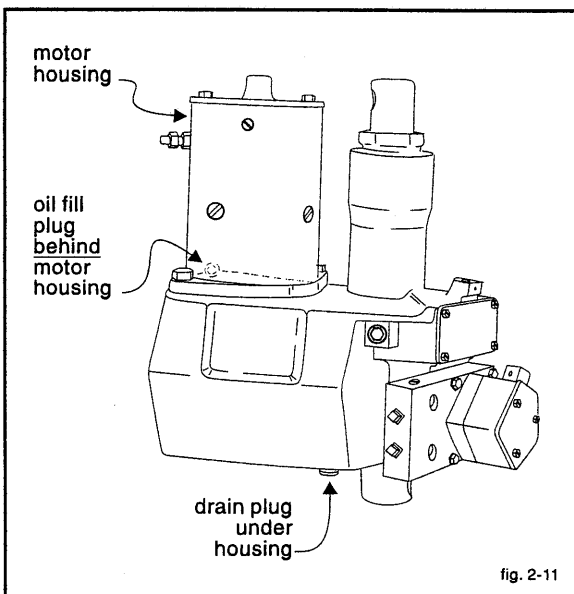

fig. 2-11

ANNUAL FLUID CHANGE

1. Push lift channel completely down, fully collapsing the lift ram.
2. Completely drain the hydraulic reservoir and Hydra-Turn® rams and refill with clean automatic transmission fluid (ATF), or WESTERN® High Performance Fluid #49311.

SYSTEM CAPACITY

- All ISARMATIC® Mark IIIa units have a 1-1/2 quart reservoir.
- ISARMATIC® Mark IIIa Extra Duty with 1-1/2" x 10" Hydra-Turn® rams have 2-1/8 quart system capacity.
- ISARMATIC® Mark IIIa Heavy Duty with 2" x 16" Hydra-Turn® rams have 2-3/4 quart capacity.

PACKING NUT ADJUSTMENT

Periodically check lift ram and Hydra-Turn® ram packing nuts for tightness.

- If packing nuts are loose, or leakage appears while lifting or angling plow, tighten not more than 1/4 turn after you feel the packing nut contact the packing.
- If leakage continues, replace packing set.

Packings not used for a period of time may show signs of oil weep. This usually stops after use.



CAUTION: Never overtighten the jam nuts. Over-tightening causes high friction and premature seal failure.

S 2-12

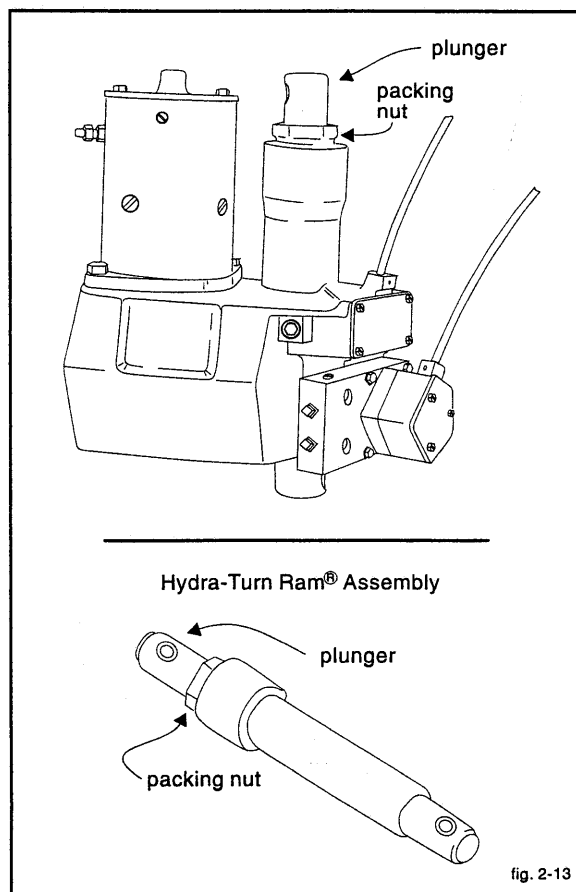

fig. 2-13

LIFT AND ANGLE PLUNGERS

1. When not in use, push **lift** channel all the way down to protect the **lift** plunger from rusting and pitting.
2. During storage, grease all exposed chrome surfaces on the angle plungers to prevent corrosion.

PUMP INLET FILTER SCREEN

Clean the pump inlet filter screen annually and/or when the pump is starving for fluid.

Replace the filter if the screen is damaged.

NOTE: See the *Breakdown and Reassembly* section for directions on how to remove pump to clean or replace filter.

Torque all capscrews as follows:

- Die-cast pump mounting capscrews: 175-185 in. lbs.



CAUTION: Do not over torque.

S 2-14

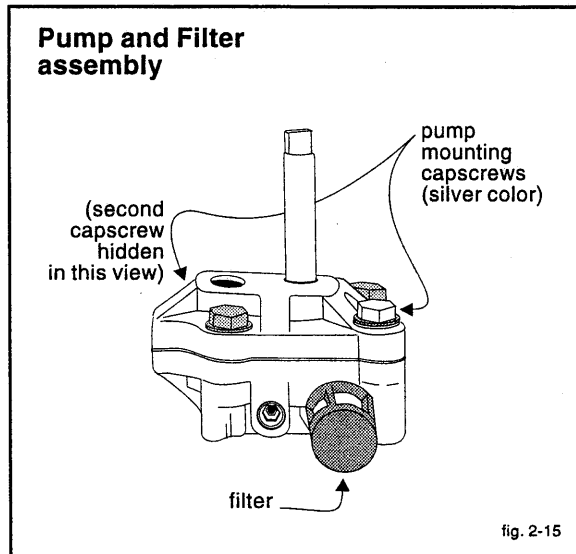

fig. 2-15

- Motor-mounting capscrews: 15/20 ft. lbs.

LIFT AND ANGLE CYCLE TIME

Definitions: "Lift time" is the time it takes for the plow to be raised from the ground to a fully raised position. "Angle time" is the time it takes for the plow to move from a fully angled position in one direction to the fully angled position in the opposite direction.

- Lift and angle times should match the chart below.

Refer to the Troubleshooting Guide in this manual if you exceed the values.

MODEL	LIFT TIME	ANGLE TIME
Standard	2 sec.	4 sec.
Extra-duty		
Heavy-duty	4 sec.	8 sec.

fig. 2-16

ISARMATIC® Mark IIIa - Cable

CONTROL CABLES

1. Verify that the control cables have more than an 8" bend radius. A radius that is too tight will cause inner wire binding.
2. Clean valve enclosures of all moisture and corrosion, and lubricate.

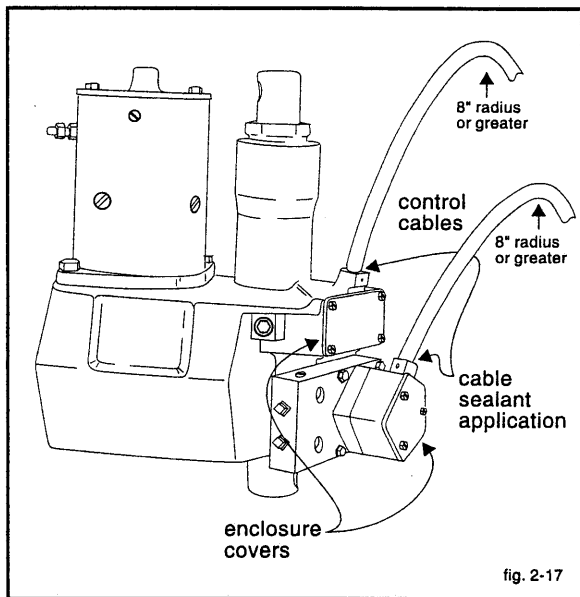

3. Seal both housing cable entries with WESTERN® #56195 Cable Sealant, or other comparable non-hardening silicon.
4. Replace control cables that show excessive backlash (more than 1/8"), inner wire yielding, or fractures.

HYDRAULIC HOSES

Check for leaks, chaffing, and cracked or worn surfaces. Replace as needed.

Electrical

ELECTRICAL INSPECTION

1. Inspect and clean all electrical connections, including grounds.
 - Apply **dielectric grease** (WESTERN® #56099) to all connections and terminals.
2. Inspect and test the battery. Recharge or replace as needed.
 - Minimum vehicle electrical system: 70 amp hr/550 CCA battery, 55 amp alternator.
3. Inspect the motor.
 - a) Remove the motor cap.
 - b) Inspect and clean the motor.
 - c) Replace brushes if excessively worn.
4. Inspect all headlights for proper functioning. Replace bulbs as needed.

NOTE: To comply with NHSTA regulations, vehicle and snowplow lights must work.

Snowplow Accessories

DEFLECTOR

1. Inspect the deflector material for fatigue and/or fractures. Replace if necessary.
2. Tighten all fasteners.
3. Inspect and insure that the curl brace is properly installed.

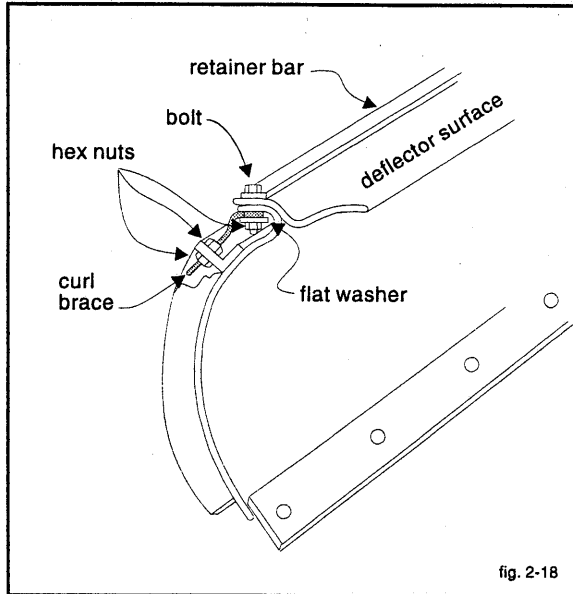

RUBBER CUTTING EDGES

1. Inspect for wear or damage. Replace if necessary.
2. Tighten all fasteners.
3. Adjust overhang up or down at slotted bolt holes for desired performance in varying snow conditions, such as:
 - a) Light snow and slush: 3"
 - b) Normal snow conditions: 2"
 - c) Hard-packed snow and ice: 1"

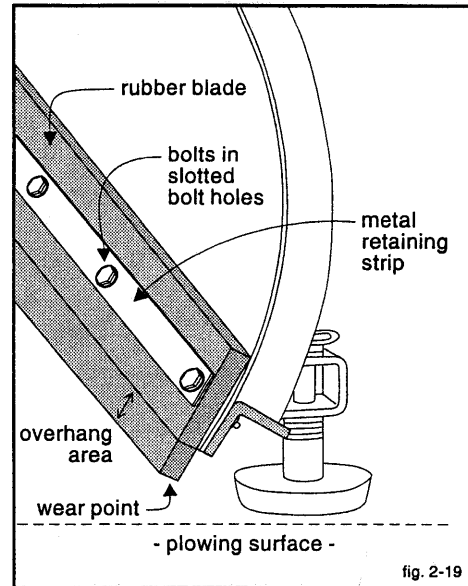

BLADE GUIDES

Insure that both blade guides are straight and positioned properly in order to aid the snowplow operator's visibility.

Description of Major Components

Components

The major mechanical components of the ISARMATIC® Mark IIIa hydraulic system are the:

- Mark IIIa Cab Control
- Motor Relay
- Mark IIIa Hydraulic Unit
- Hydra-Turn® Rams

MARK IIIA CAB CONTROL

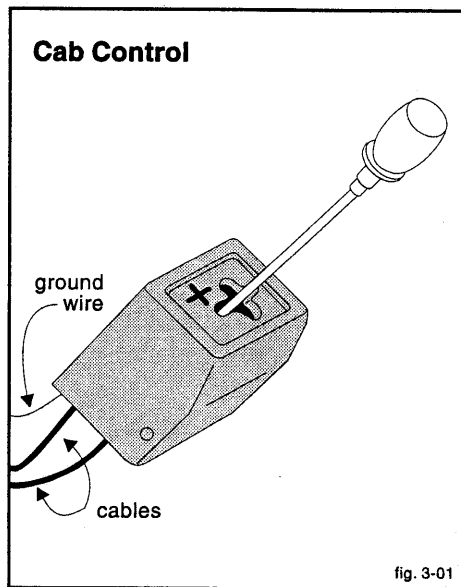

The **MARK IIIA CONTROL ASSEMBLY** is an electro/mechanical device that controls angling and the raise-lower movement of the snowplow blade.

Two push-pull **CABLES** link the cab control to the ISARMATIC® valves. One cable actuates the 3-way valve controlling the raise-lower movement of the blade. The other cable actuates the Hydra-Turn® 4-way valve controlling plow angling.

MOTOR RELAY

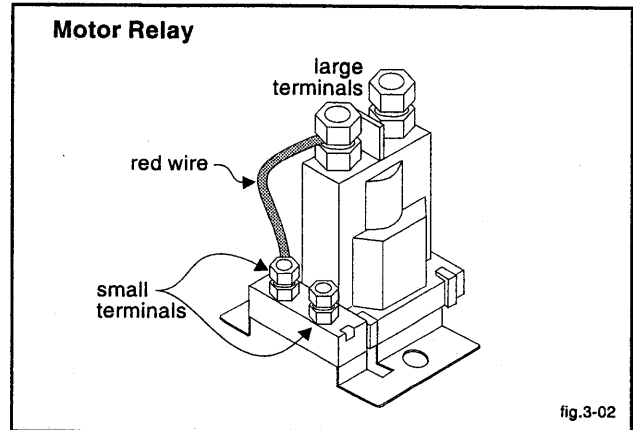

The **MOTOR RELAY** is negatively activated by the cab control which provides a circuit of low resistance between the vehicle's battery and the ISARMATIC® motor, which energizes the motor.

This relay eliminates the need for long, heavy battery cables running from the switch inside the vehicle to the vehicle battery. It lets the current take a direct path from the battery to the hydraulic unit motor.

THE MARK IIIA HYDRAULIC UNIT

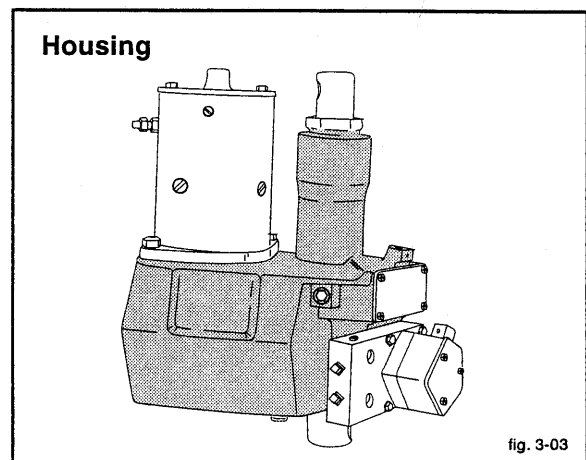

The **HOUSING** for the hydraulic unit is an aluminum casting that forms the pump reservoir, the lift cylinder bore, and the body for the 3-way valve. The hydraulic pump sits inside this reservoir where it is continually submerged in oil. The Hydra-Turn® 4-way valve and other components are attached to the exterior of the housing.

ISARMATIC® Mark IIIa - Cable

Electric Motor

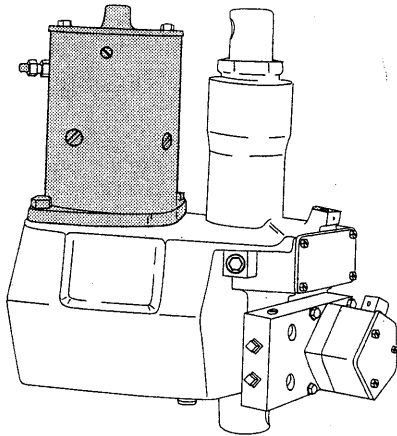

fig. 3-04

The **ELECTRIC MOTOR** powers the hydraulic pump. It is a 12-volt DC motor, similar to some automobile starter motors. It consists of a steel frame with attached fields, armature, brush assembly, cover cap, and mounting flange.

Hydraulic Pump

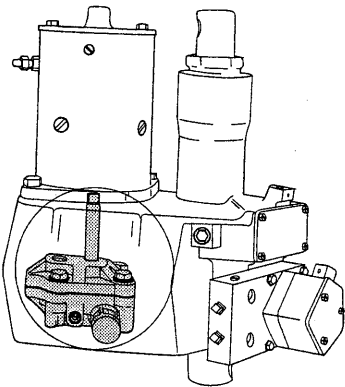

fig. 3-05

The **HYDRAULIC PUMP** is located directly under the motor in the reservoir providing the fluid flow necessary to operate the hydraulic rams.

Pressure Relief Valve and Filter Screen

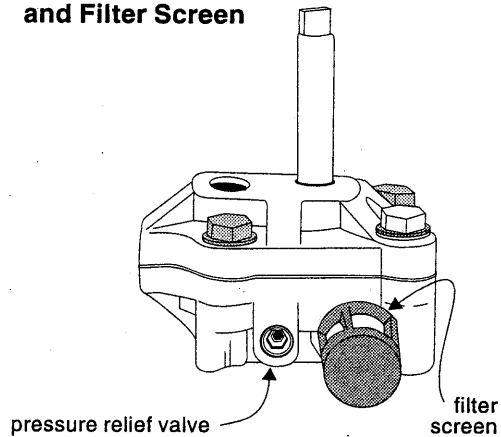

fig. 3-06

The pump contains a **PRESSURE RELIEF VALVE**. Located in the pump outlet passageway, it consists of a ball, a spring, and an adjusting screw which relieves excessive system pressure, protecting the pump and other components from damage.

The pump also contains a **FILTER SCREEN** which protects the system from contaminated fluid. This filter screen must be kept clean at all times. Under no circumstances should the pump run without this filter screen installed.

3-Way Lift Lower Valve

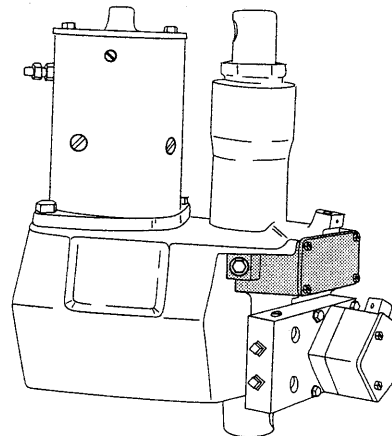
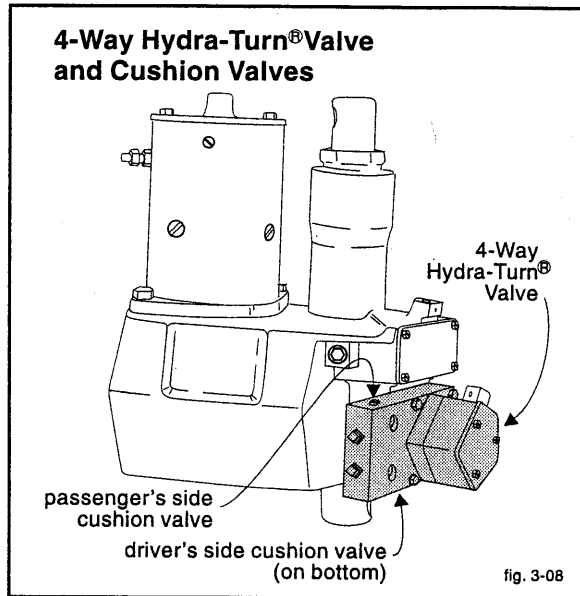

fig. 3-07

The **3-WAY LIFT / LOWER VALVE** is located in the hydraulic housing, to the right of the nameplate. It controls the raise/lower movement of the snowplow blade and is mechanically operated by the cab control cable assembly.

DESCRIPTION OF MAJOR COMPONENTS

4-Way Hydra-Turn® Valve and Cushion Valves



The **4-WAY HYDRA-TURN® VALVE** is attached to the hydraulic housing, directly below the 3-way valve. It controls plow angling and is mechanically operated by a cable linked to the cab control.

The **CUSHION VALVES** (cross-over relief valves) are located in the Hydra-Turn® Valve manifold. They act as an impact absorbing device, protecting both the vehicle and plow when an immovable object is struck by the blade.

Lift Ram Assembly

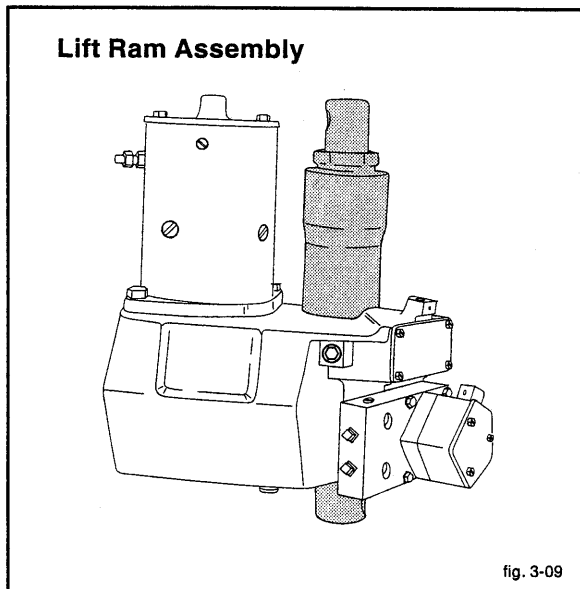

The **LIFT RAM ASSEMBLY** is a single acting, hydraulic ram with a 6-inch stroke. It is built into the housing and provides lifting.

HYDRA-TURN® RAMS

Hydra-Turn Ram® Assembly

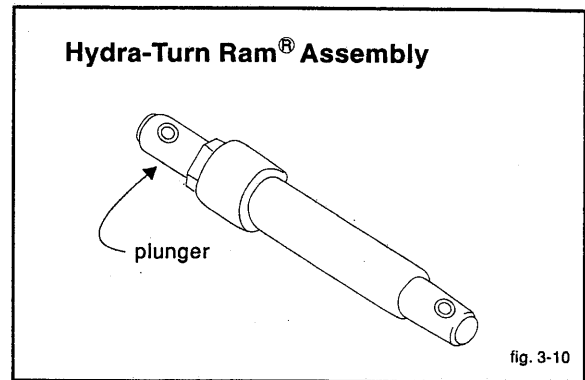

The **HYDRA-TURN® RAMS** are single-acting hydraulic cylinders, having a 10-inch stroke (16-inches on the Heavy Duty model) that provides angling.

The **QUICK COUPLERS** provide a quick way to connect and disconnect the Hydra-Turn® hoses for snowplow installation and removal.

ISARMATIC® Mark IIIa - Cable

Theory of Operation

The ISARMATIC® Mark IIIa Hydraulic System provides power to raise and angle the plow.

Raising, and angling to the right and left are accomplished by electrical and mechanical means. Lowering operates only by mechanical means.

ELECTRICAL

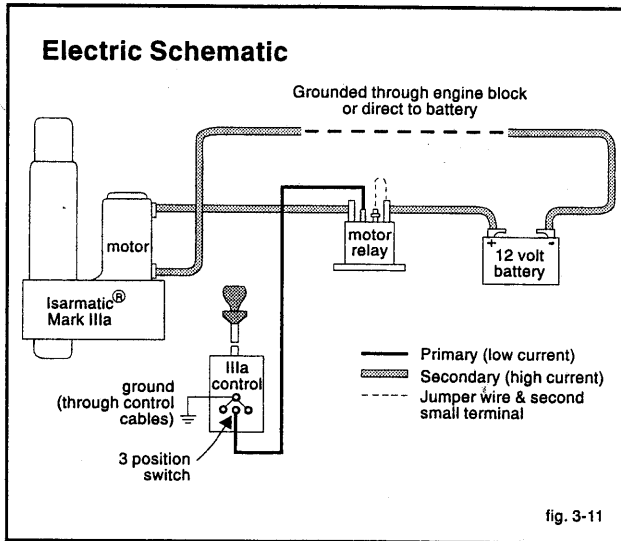

When the cab control is in the RAISE, LEFT (L), OR RIGHT (R) position, contacts inside the control are grounded through the control cables to the hydraulic unit, completing the grounding of the motor relay (primary) circuit, which energizes the motor relay coil.

The energized relay coil causes the contacts inside the motor relay to close, completing the battery/motor (secondary) circuit. A direct, low resistance current path is now available to energize the electric motor.

Current flows through the motor and back to the battery via the ground cable.

RAISING PLOW

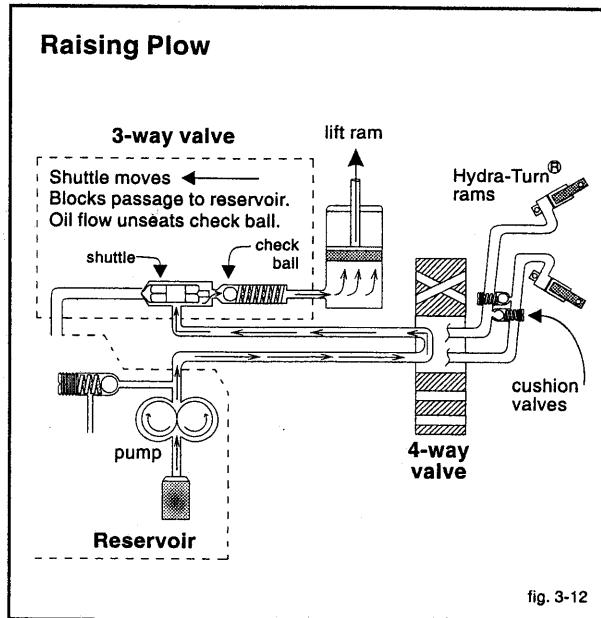

Moving the IIIa cab control to the RAISE (R) position activates the motor relay, energizing the motor. The cable moves the shuttle into the lift valve. This action closes the passageway to the reservoir and directs fluid flow from the pump outlet to the lift ram.

Oil passes through the 4-way Hydra-Turn® valve and into the 3-way lift/lower valve. Oil flows around the shuttle stem and pushes the check valve ball off its seat. There it enters the lift ram assembly, pushing the plunger (and the snowplow) up.

DESCRIPTION OF MAJOR COMPONENTS

LOWERING FLOW

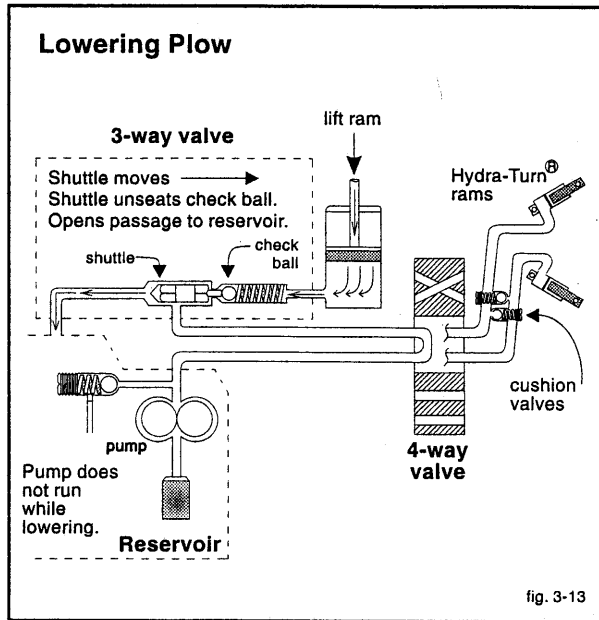

Moving the Illa cab control to the LOWER (L) (float) position moves the shuttle stem to push the check valve ball off its seat allowing the snowplow weight to push oil back into the reservoir. The motor does not operate.

ANGLING FLOW TO RIGHT OR LEFT

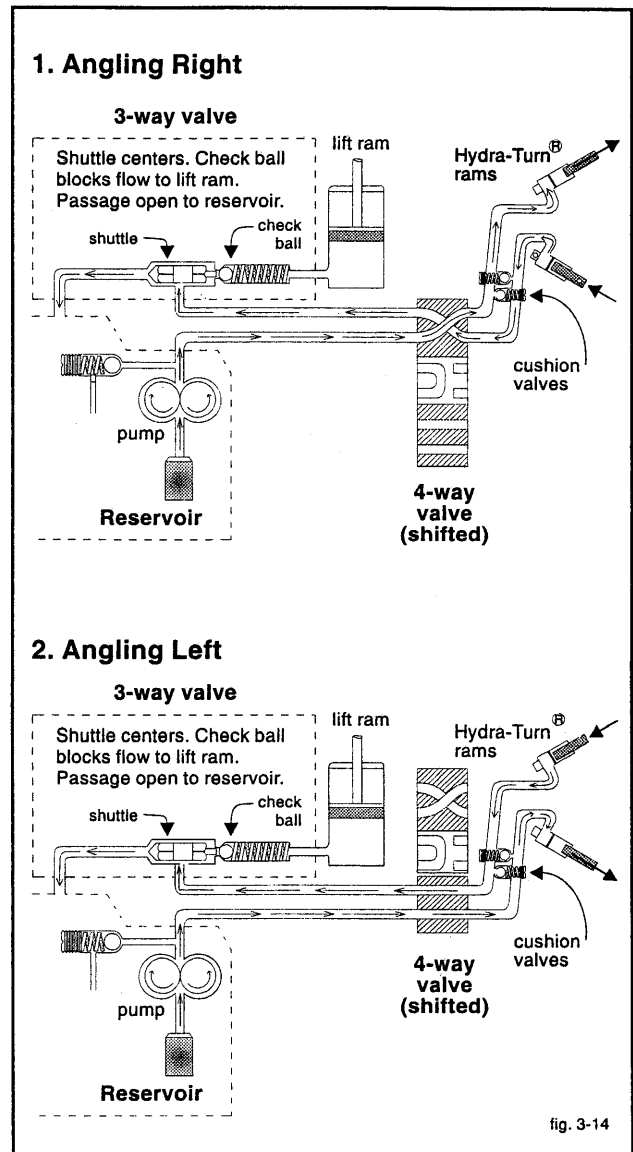

Moving the Illa cab control to the RIGHT (R) position rotates the rotor 45° clockwise so the recessed pockets provide passages between the pump supply and left hydraulic ram and the reservoir port. Oil from the pump flows through the 4-way valve and enters the left hydraulic ram. As the ram extends, the plow angles to the right. As the plow angles, the right hydraulic ram collapses, pushing oil through the 4-way valve and past the shuttle in the 3-way valve to the reservoir.

ISARMATIC® Mark IIIa - Cable

4-Way Hydra-Turn® Valve

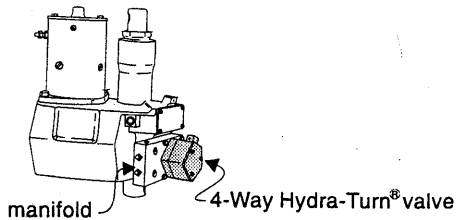

Top view of rotor shown in curb-side position angle.

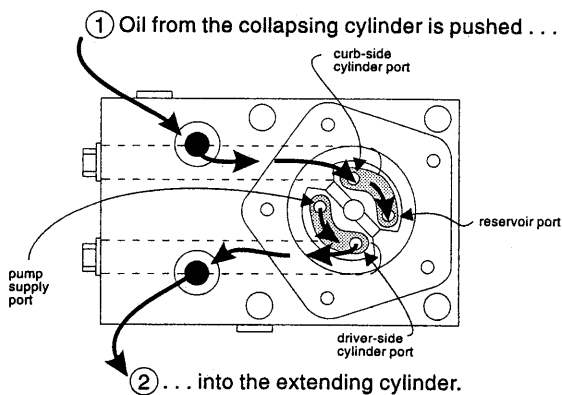

Side view of rotor.

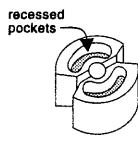

fig. 3-15

Moving the IIIa cab control to the LEFT (L) position starts the rotor 45° counterclockwise from neutral, so that the oil from the pump flows through the 4-way valve and enters the right Hydra-Turn® ram. As the

ram extends, the plow angles to the left. The left Hydra-Turn® ram collapses, pushing oil past the shuttle in the 3-way valve to the reservoir.

Top view of rotor shown in driver-side position angle.

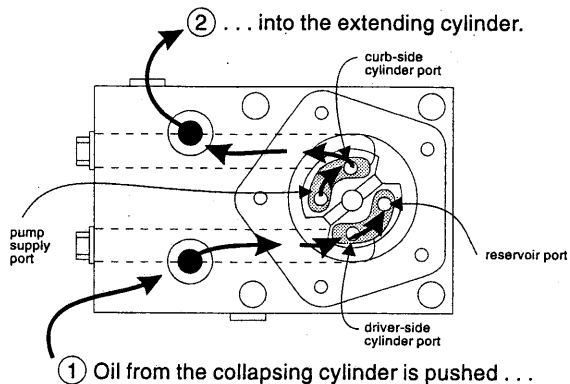
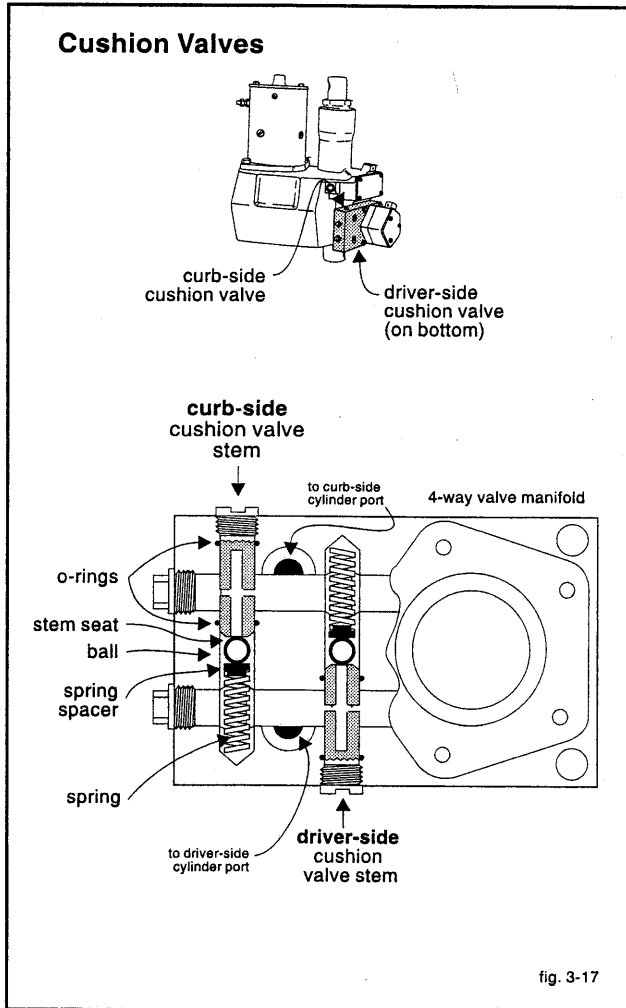

fig. 3-16

CUSHION VALVES



While plowing, oil is trapped in the extended Hydra-Turn® ram. When the blade meets an object, pressure rises in the extended Hydra-Turn® ram.

As pressure in the ram exceeds the spring force holding the checkball against the seat, the cushion valve ball unseats, allowing oil to flow to the collapsed ram. The blade angles in the opposite directions, allowing the blade to go around the obstacle. This prevents damage to the hydraulic system and vehicle.

ISARMATIC® Mark IIIa - Cable

Troubleshooting Section

Most service can be performed with the hydraulic unit left on the vehicle. This saves time and aids in the evaluation of the entire system, which includes the electrical system, cables, Mark IIIa cab control, etc.



WARNING: Do **NOT** stand between the vehicle and blade, or directly in front of the blade when it is being raised, lowered, or angled. Clearance between the vehicle and the blade **decreases** as the blade is operated. Serious bodily injury can result from the blade striking a body or dropping on the feet or hands.

S 4-01

Troubleshooting Guide										
IIIa Control Position	Problem Description	Define Problem and Follow Steps Indicated								
Angle	Blade will not angle or angles too slowly. Time: 4 seconds. (8 seconds - Heavy Duty)	Motor does not run. See (B)	Check oil level.	All functions are slow. See (A)	Verify 4-way valve lever travel. See (E)	Adjust lift valve out. See (F & F1)	Check disconnect couplers and hydraulic ram nuts.	Remove pump. Clean filter screen. ↓		
Raise	Blade will not raise or raises too slowly. Time: 2 seconds. (4 seconds - Heavy Duty)				Verify 3-way valve lever travel. See (D)	Adjust lift valve in. See (F & F1)	Check lift ram packing nut adjust. Refer to Plow Tune Up & Inspection section.			
Neutral	Blade will not remain angled while plowing.	Inspect and adjust cushion valves. See (C)								
Neutral	Motor continues to run in neutral.	Disconnect IIIa control wire from motor relay.	If motor runs, motor relay is shorted. Replace motor relay.			Further troubleshooting requires the use of test equipment. See an authorized Western Distributor, or Refer to the Western Hydra-Lectric™ Test Kit, and/or a Western Hydraulic Service School Video.				
			If motor stops, short is in primary (IIIa control) circuit. Isolate and repair.							
Angle	Blade raises while angling.	Verify 3-way valve lever travel. See (D)	Adjust lift valve out. See (F & F1)							
Neutral	Blade lowers in neutral.		Adjust check valve out. See (F & F2)	Remove check valve. Inspect O-ring and seat. Refer to Breakdown and Reassembly section.						
Lower	Blade lowers too fast.									
Lower	Blade will not lower, or lowers too slowly.		Adjust check valve in. See (F & F2)	Check lift ram packing nut adjustment. Refer to Plow Tune-Up & Inspection section.						

fig. 4-02

**Hydraulic Unit -
Part Reference**

The following illustration shows the parts of the hydraulic unit:

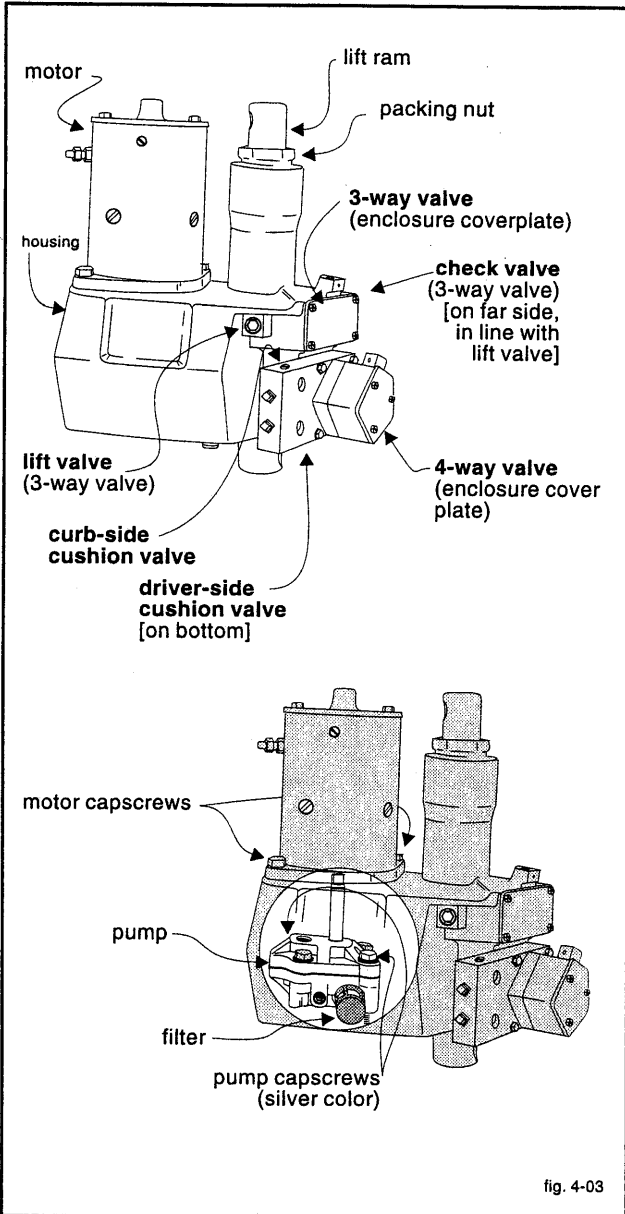

A. Pump Pressure Test

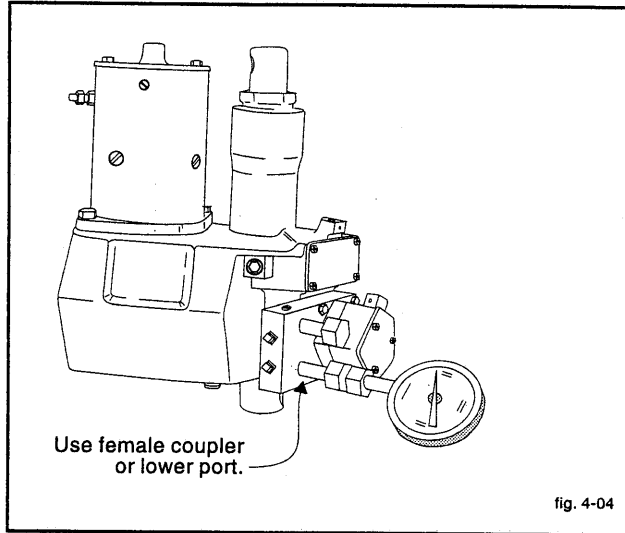

NOTE: Poor condition of the battery or motor will cause invalid test results.

1. Disconnect the lift chain and hoses to Hydra-Turn® rams.
2. Install a 3000 PSI minimum pressure gauge into female coupler on the valve manifold. Use Western Hydraulic Test Kit # 56679.
3. Move the IIIa cab control to angle LEFT (L) and read gauge.
4. The pump is OK if the pressure is 1650-1850 PSI (1450-1650 for sport/utility blades).
5. If the pressure is low:

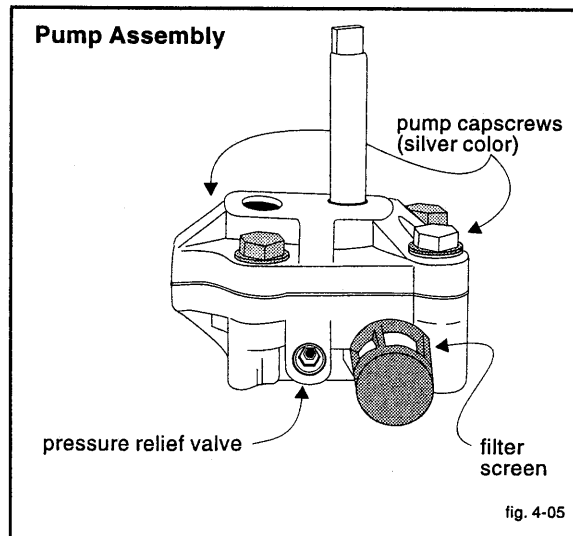

- a) Remove the pump.
- b) Clean or replace the filter.

- c) Adjust the pressure relief valve. 1/4 turn equals approximately 225 PSI.
- d) Re-assemble. The pump capscrews require 175/185 in. lbs. torque. The motor capscrews require 15/20 ft. lbs torque.

B. Relay Test

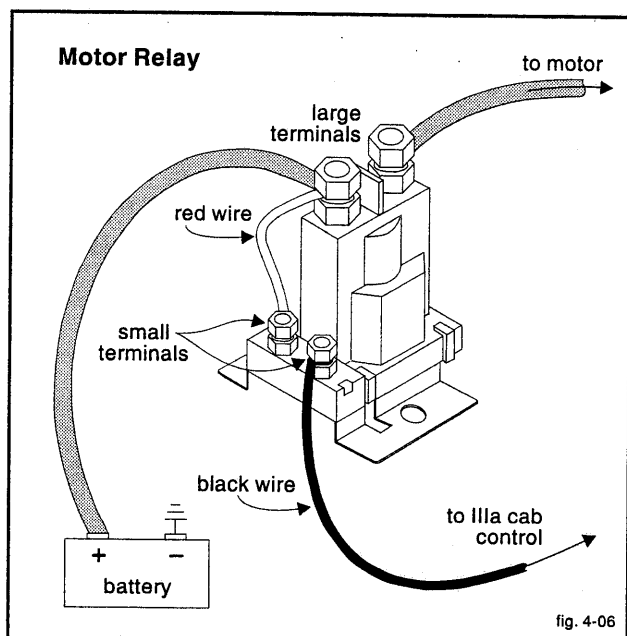

NOTE: Perform this test if the motor does not run with IIIa cab control in RAISE, ANGLE RIGHT (R), or ANGLE LEFT (L). Battery has sufficient charge to start the engine.

1. Disconnect the lift chain and hoses to the Hydra-Turn® rams.
2. Check all electrical cables and connections, including grounds. Clean and tighten, if necessary.



WARNING: Protect the top of the battery. Sparks from testing operations could cause battery gases to explode causing severe eye or body burns, or other personal injuries.

S 4-07

3. Use a jumper wire to connect the small terminal with BLACK wire on the motor relay to the NEG - terminal of the battery.
 - a) If the motor runs, the problem is in the IIIa control (primary) circuit.
 - Check for broken wire, loose connections, or bent contacts in the IIIa cab control.

- Check to see if the IIIa control is grounded (through push-pull cables).
- b) If the motor does not run:
 - Use a jumper wire to connect the POS + terminal of the battery to the small terminal with RED wire attached on the motor relay.
 - Operate the IIIa control to RAISE, angle LEFT or RIGHT.
- c) If the motor then runs, check for broken or damaged RED wire on the relay.
- d) If the motor still does not run, use heavy jumper cables to jump the two large terminals on top of the motor relay.
- e) If the motor runs, replace the motor relay.
- f) If the motor does not run:
 - Remove the motor.
 - Check the pump shaft rotation.
 - ♦ If the pump shaft is tight, repair or replace the pump.
 - ♦ If the pump shaft is loose, replace the motor.

C. Cushion Valve Adjustment

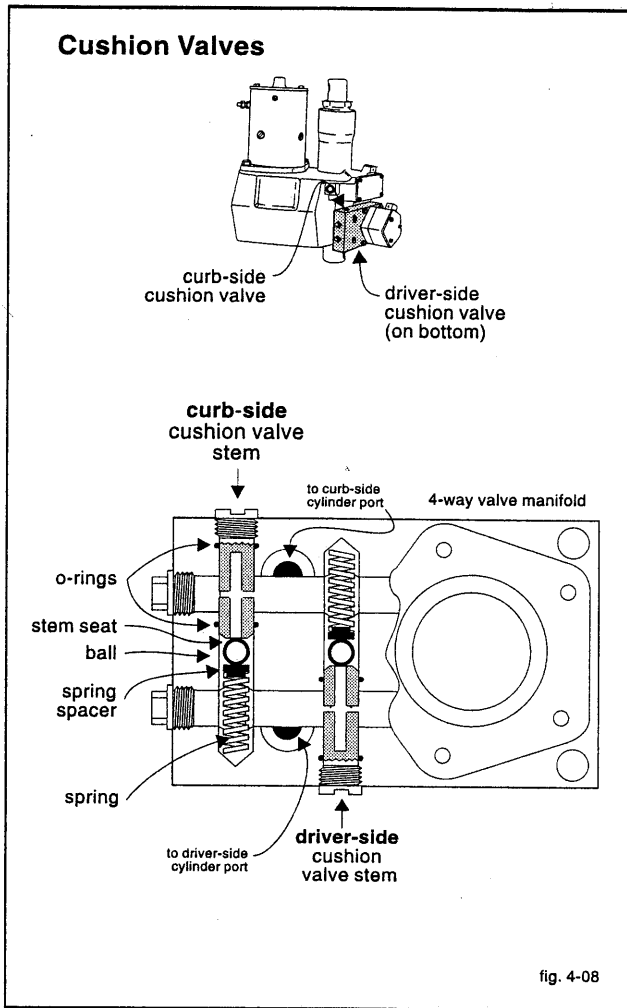

- d) Before re-installing a new or used valve stem, re-seat by placing ball on wooden block. Hold stem seat on the ball and lightly strike the stem squarely with a hammer.



CAUTION: The valve stem may bend if not struck squarely.

S 4-09

- e) Apply anti-seize compound or grease to the threads of the stem.
- f) Re-assemble the components and adjust. See *Valve Adjustment* below.

2. Valve adjustment:

- a) Tighten the cushion valve stem as much as possible, until the spring is fully compressed.
- b) Back off the valve stem (rotate counter-clockwise) 1-1/4 turns. This adjustment will cause the cushion valve to open at approximately 3,500 PSI.

1. Valve inspection:

- a) Remove cushion valve stem, ball, spring spacer, and spring. (A magnetic probe may be necessary to remove the ball, spring spacer, and spring on the upper valve.)
- b) Inspect valve stem, seat, and o-rings for contamination or wear. Clean stem and o-rings. Replace o-rings if damaged.
- c) Inspect ball, spring spacer, and spring for contamination or wear. Clean or replace as necessary.

D. 3-Way Valve Lever Travel

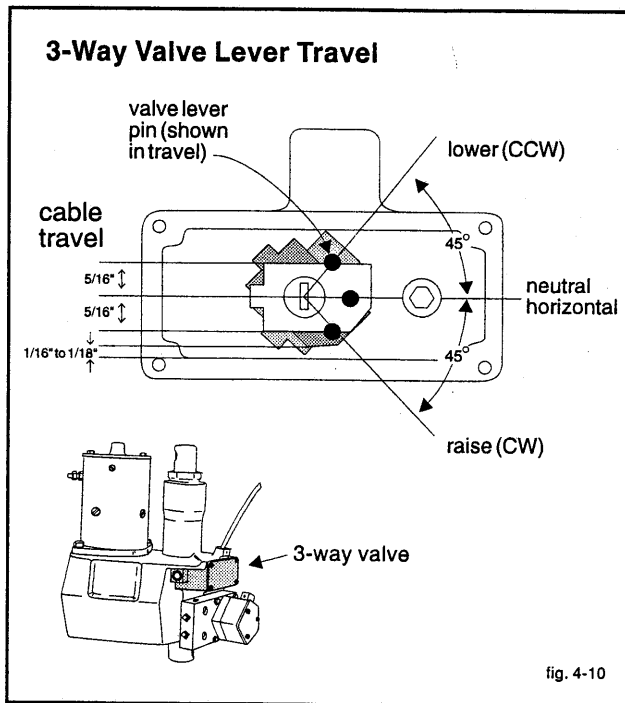

1. Check the valve lever travel:
 - a) Disconnect the hydraulic hoses and the lift chain.
 - b) Remove the 3-way valve (rectangular) cover plate.
 - c) Move the IIIa cab control between RAISE (R) and LOWER (L). Observe the valve lever travel and positions. Verify 45° travel in each direction..
 - d) Lock the IIIa cab control in neutral. The 3-way lever should be in the neutral position, as shown.
2. Possible causes of inadequate travel, or an incorrect valve lever position:
 - Dirt or ice buildup in the enclosure.
 - The cable is disconnected in the valve enclosure, or in the IIIa cab control.
 - The cable is bound, kinked, or broken. (8" minimum radius)
 - The dog point set screw is not positioned in groove of the control cable.
 - The lift valve is adjusted too far in (3-way valve only). See F and F1.

NOTE: Seal cable entries into the housing with WESTERN® #56195 Cable Sealant.

E. 4-Way (Angle) Valve Lever Travel and Adjustment

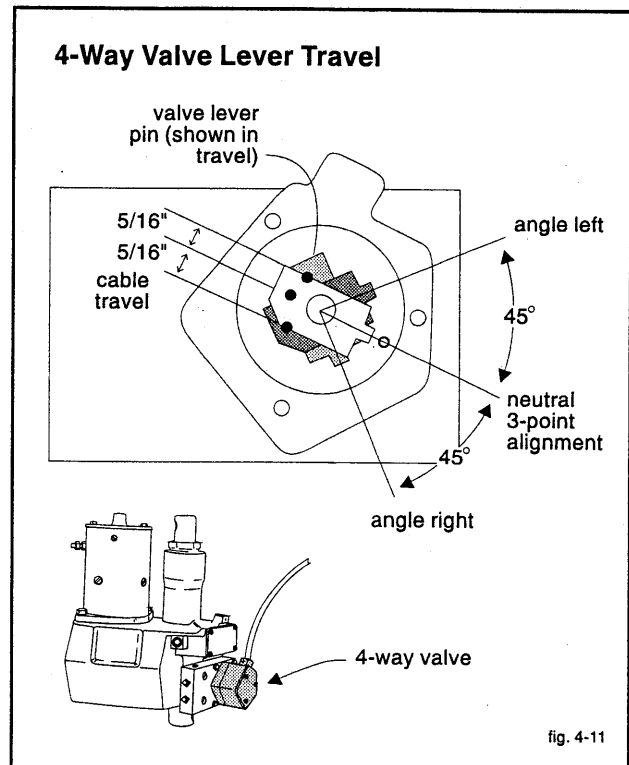

1. Check the 4-way (angle) valve lever travel:
 - a) Disconnect the hydraulic hoses and the lift chain.
 - b) Remove the 4-way valve (5 sided) cover.
 - c) Move the IIIa cab control between angle RIGHT (R) and LEFT (L), and observe the lever movement. Verify 45° travel in each direction.
 - d) Adjust per the illustration for equal travel in each direction.

F. 3-Way (Raise/Lower) Valve Adjustment

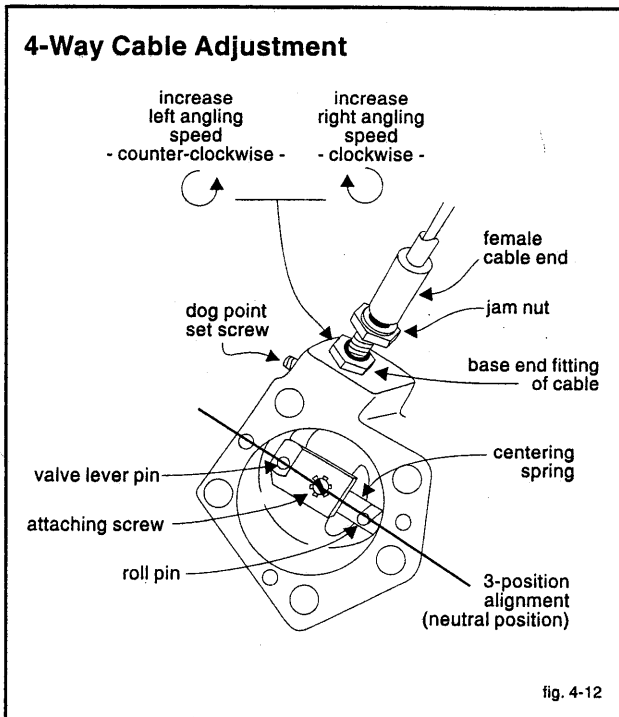

WARNING: Do **NOT** stand between the vehicle and blade, or directly in front of the blade when it is being raised, lowered, or angled.

Clearance between the vehicle and the blade **decreases** as the blade is operated. Serious bodily injury can result from the blade striking a body or dropping on the feet or hands.

S 4-13

NOTE:
Sensitive adjustment.
Make 1/8 turn at a time.

General Directions:

- e) Lock the IIIa control in neutral. The 4-way lever should be in line, or slightly down from the "neutral 3-point alignment" indicated in the illustration.
2. Possible causes of inadequate travel or incorrect valve lever position are:
 - Dirt or ice buildup in the enclosure.
 - The cable is disconnected in the valve enclosure, or in the IIIa control.
 - The cable is bound, kinked, or broken. (8" minimum radius)
 - The dog point set screw is not positioned in the groove of the control cable.
 - Valve may have insufficient ring/rotor clearance. If so, obtain WESTERN® 4-Way Rebuild Kit, #49005.

NOTE: Seal cable entries into the housing with WESTERN® #56195 Cable Sealant.

F1. Lift Valve Adjustment

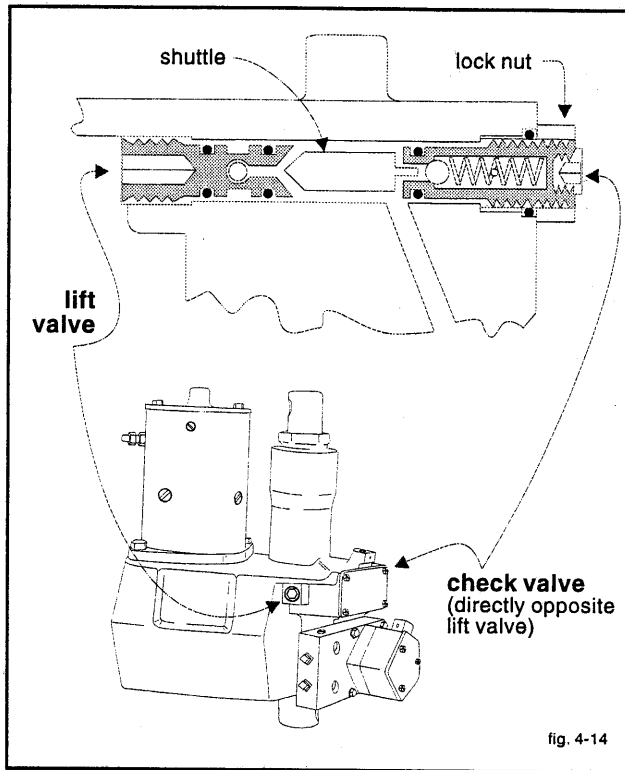

1. Turn the valve stem out (counterclockwise) in 1/8 turn increments until RAISE (R) does **not** function properly.
2. Turn the lift valve in using 1/8 turn increments until the unit is able to lift the blade.

NOTE: Turning the valve in more than 1/4 turn beyond the lifting point may slow the angling speed.

VALVE REPLACEMENT OR MAJOR ADJUSTMENTS:

1. Remove the cable from the valve lever pin and place the valve lever in the neutral position.
2. Apply anti-seize compound to valve threads and turn the lift valve in until it is flush to the casting surface.
3. Rotate the lever to the RAISE position. It should stop 1/16" to 1/8" from the enclosure bottom (see D.)
4. If dimension is not correct, continue to turn the valve in or out until the correct dimension is obtained.
5. Refer to the General Directions in this section for the final adjustment.

F2. Check Valve Adjustment

Adjustment techniques:

- Hold the check valve with a hex wrench when loosening or tightening the jam nut.
- Limit loosening the jam nut to 1/4 turn maximum to prevent the o-ring from being blown out.
- Tighten the jam nut to a maximum of 12 in-lb.

Adjustments:

- If the plow will not lower, or lowers too slowly, turn the check valve IN (CW).
- If the plow lowers too fast, turn the check valve OUT (CCW).

VALVE REPLACEMENT OR MAJOR ADJUSTMENTS:

1. Apply anti-seize compound to the threads and turn the check valve in until the threads are flush with the jam nut. Jam nut must be bottomed on housing.

NOTE: Earlier models used a thinner sectioned 3/16" jam nut. Three threads protrude from the jam nut when the nut is bottomed on the housing.

2. Refer to Adjustments in the section above for the final adjustment.

Breakdown and Reassembly

Repair

GENERAL

This section contains shop repair procedures for the ISARMATIC® Mark IIIA cable control. Before either of these parts are removed from the vehicle and disassembled for repair, be sure the problem has been thoroughly checked. (See troubleshooting guide in this manual.) Most problems can be corrected without the need to remove or disassemble the unit.

HYDRAULIC PUMP AND HOUSING

Through the years, different pump mounting configurations have been used. All components are interchangeable between housings, except for the pump. When ordering service housing or pump, verify pump mounting configuration.

DISASSEMBLY

Always use brass jaws when clamping hydraulic unit components in vise. All seals and o-rings should be replaced when major repair is performed. Use WESTERN® Extra Duty Seal Kit #49049 and WESTERN® Heavy Duty Seal Kit #49050. Drain oil through drain plug at front bottom of main housing before disassembly.

REASSEMBLY AND INSTALLATION

To avoid damage to o-rings and seals, coat them with oil and position them carefully before reassembly. Be sure to tighten fasteners to their proper torque value when the value is indicated in the procedure. After the ISARMATIC® unit has been reassembled, install it on the vehicle and fill it with hydraulic fluid. (See the maintenance section of appropriate owner's manual.) After final adjustments are completed, seal cable openings with WESTERN® Cable Sealant #56195 to prevent moisture and dirt from entering the housings. Be sure setscrews are in the proper groove in the cable fittings.

Warranty Repair

SERIAL NUMBER AND RMO NUMBER

Be sure to include the serial number (located on the nameplate of the ISARMATIC® unit) with any warranty claim or Return Material Order (RMO). When returning parts, include an RMO tag. An RMO tag can be obtained from Western Products Customer Service Department.

Refer to Western Product's WARRANTY MANUAL which describes the warranty policy and procedures that should be followed for processing all warranty claims.

Flat labor rates have been developed to assist distributors in calculating their labor costs when requesting warranty labor. Refer to these flat labor rates before performing each operation so that you allow the time allotted for that operation.

ISARMATIC® Mark IIIa - Cable

Reference Guide With Photos

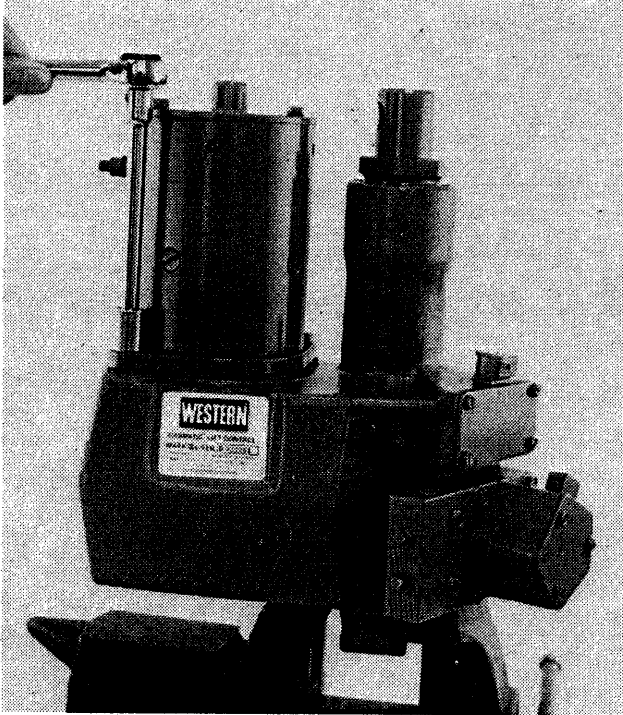

Step 1: Remove the motor by removing the two cap screws with a 5/8" socket.

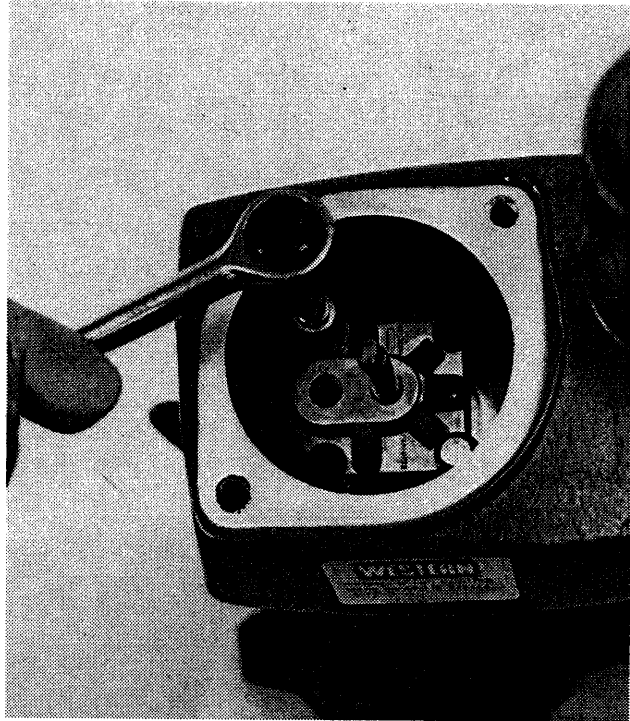

Step 2: Remove the two silver cap screws located at 10:00 and 4:00 o'clock with a 1/2" socket. Remove pump from the housing.

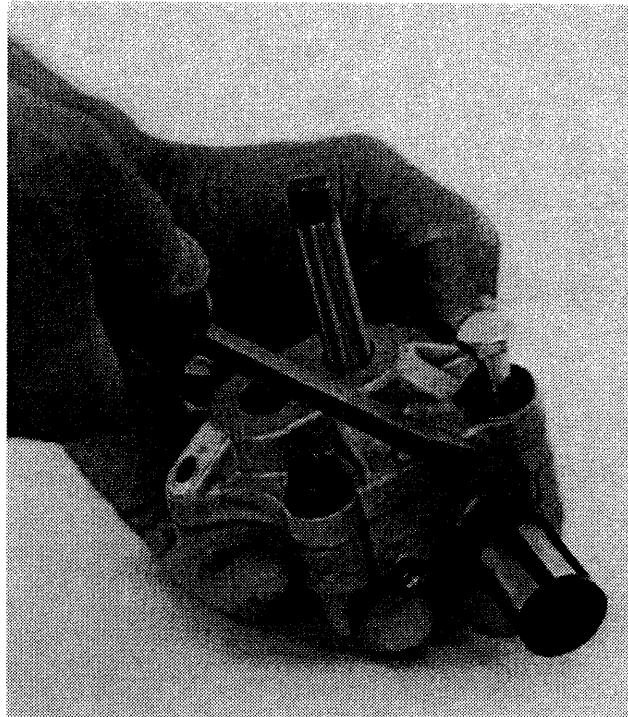

Step 3: Remove filter using a standard screwdriver. Clean filter screen with solvent or replace if damaged. To install filter, position the filter on the pump neck. Tap on with a light hammer blow.

BREAKDOWN AND REASSEMBLY

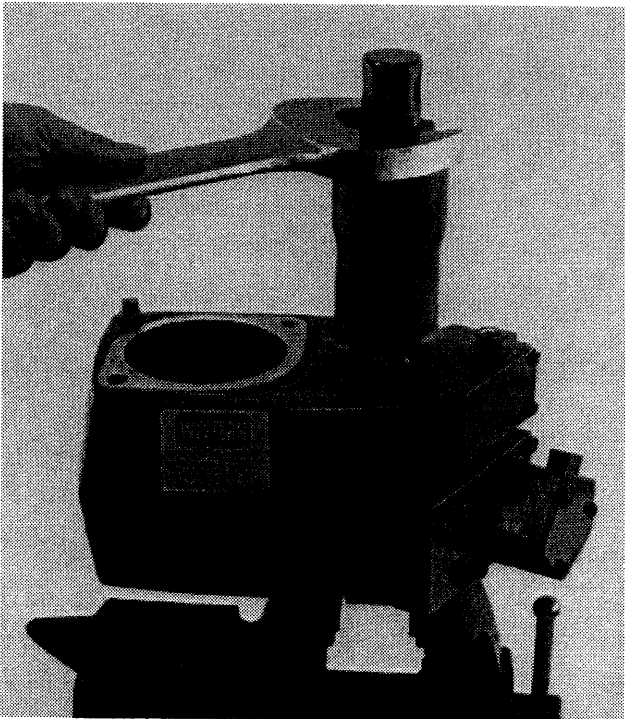

Step 4: Remove packing nut, packing set, and plunger assembly from the lift cylinder housing. Turn packing nut counter-clockwise.

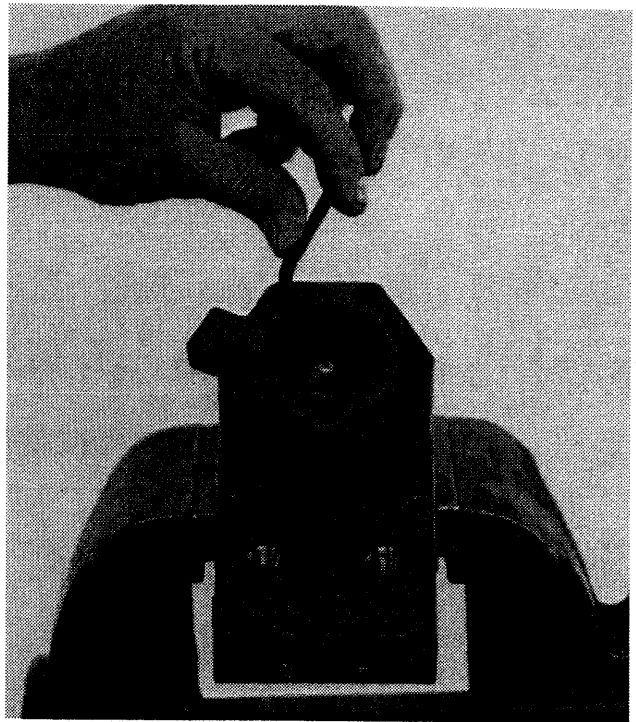

Step 6: Use a 3/16" hex wrench to remove the enclosure from the 4-way valve.

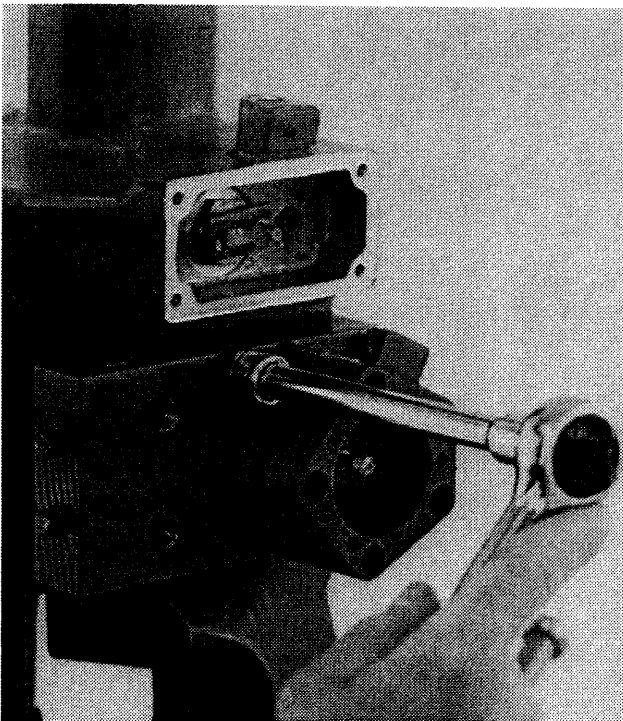

Step 5: Remove the 4-way valve using a 3/8" socket.

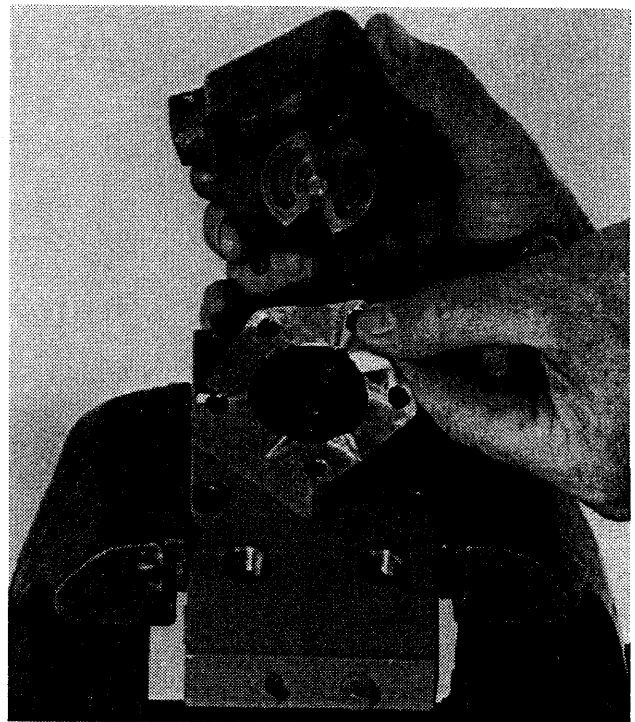

Step 7: Inspect the mylar shim spacer. Replace shim with WESTERN® rebuild kit #49005 if valve shows excessive wear or shim is damaged.

ISARMATIC® Mark IIIa - Cable

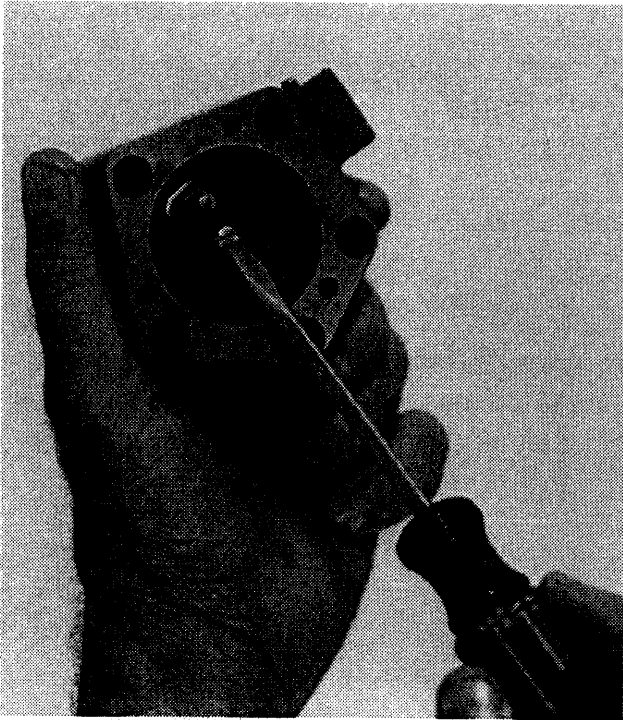

Step 8: Remove the retainer screw and valve lever.

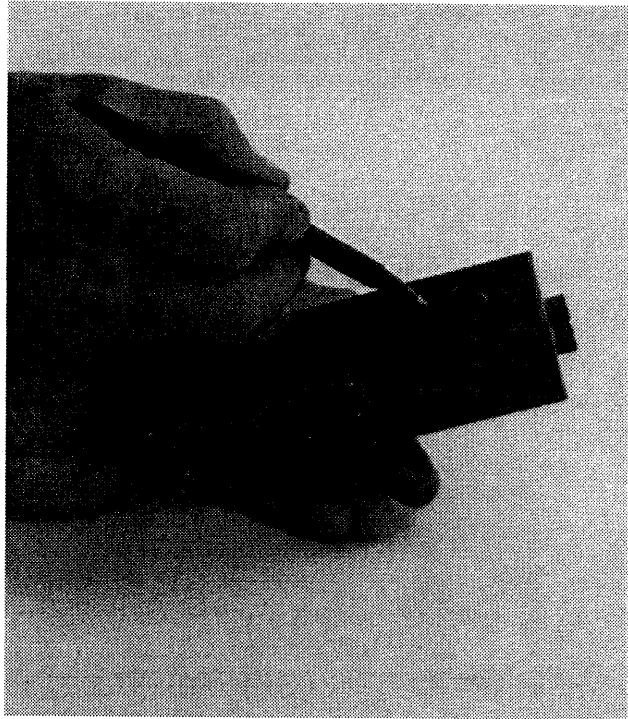

Step 10: Draw a line across the cushion valve stem and valve manifold. Count the turns as you unscrew the stem from the valve manifold.

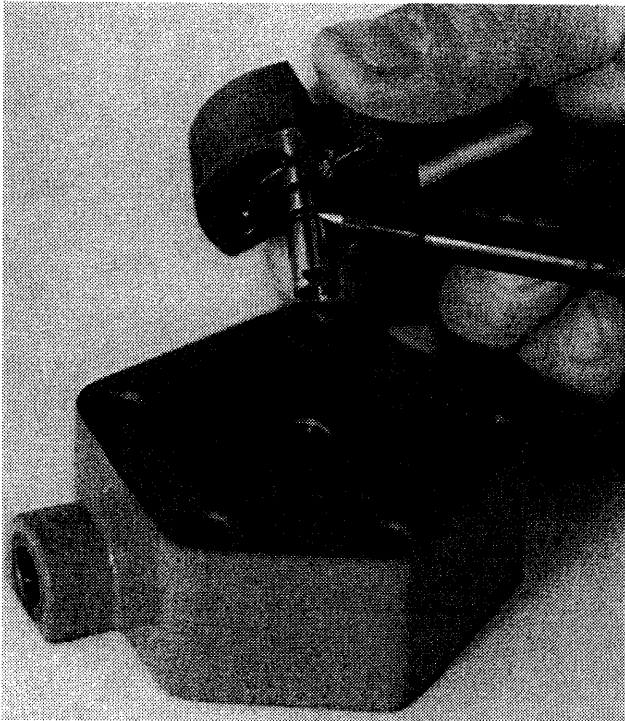

Step 9: Remove the rotor from the cable and linkage enclosure. Install a new o-ring on the rotor shaft.

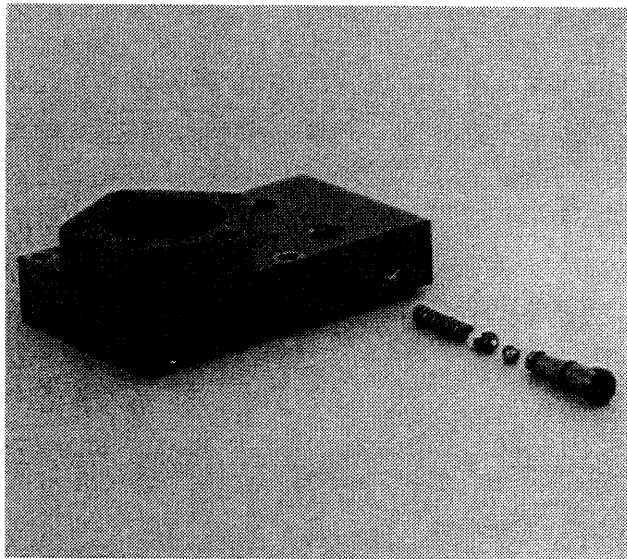

Step 11: Remove the valve stem, ball, spring spacer, and spring from valve manifold block. Clean parts. Replace o-ring or complete assembly if damaged. Before reassembly, place ball on hard wood block, hold stem seat on ball, and lightly strike stem squarely with a hammer. Coat parts with oil and reinstall them in their proper order.

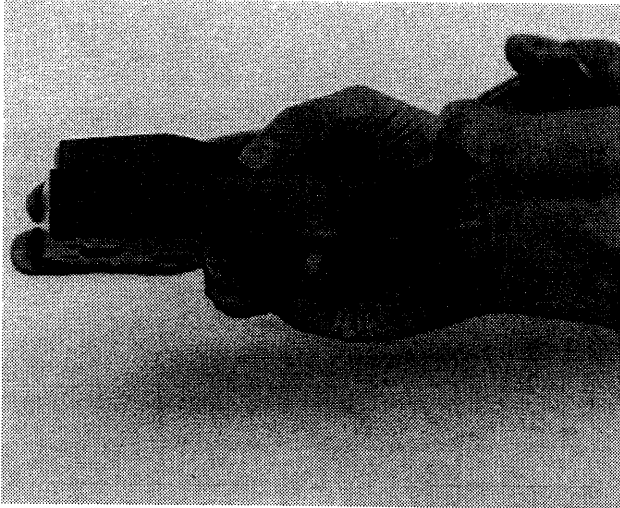

Step 12: Tighten the valve stem 1/4 turn beyond its original position.

Alternate method:

1. Adjust by tightening cushion valve stem as much as possible (until spring is fully compressed).
2. Back off valve stem (rotate counterclockwise) 1-1/4 turns to attain 3500 psi cushion relief.

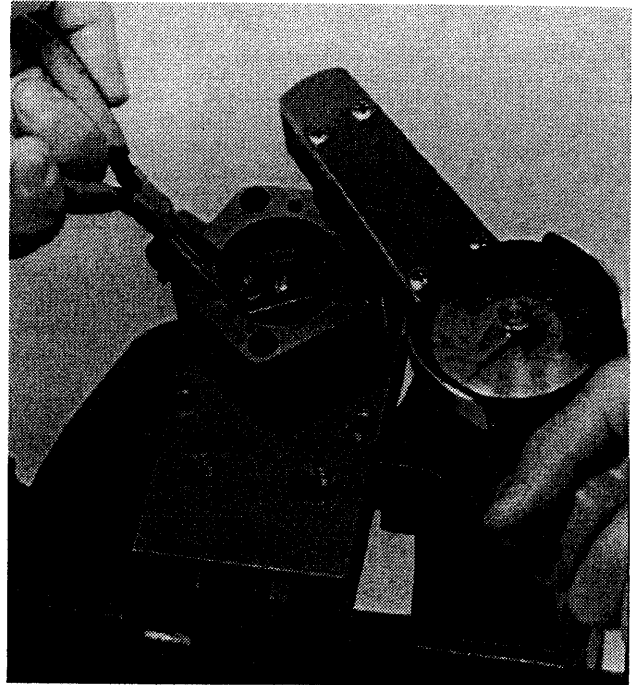

Step 13: Reinstall enclosure and torque capscrews following a star pattern in 50 in. lb. increments while rotating valve lever. Equally torque all five capscrews to 145 in. lbs. Valve lever must rotate freely.

NOTE: If valve lever does not rotate freely, verify torque or choose a different shim.

ISARMATIC® Mark IIIa - Cable



Step 14: Unscrew lift valve with 1/4" hex wrench. Inspect o-rings and lift valve seat. Clean or replace if damaged.

Old-style lift valve: Remove locking set screw with 3/32" hex wrench and unscrew lift valve with large standard blade screwdriver.

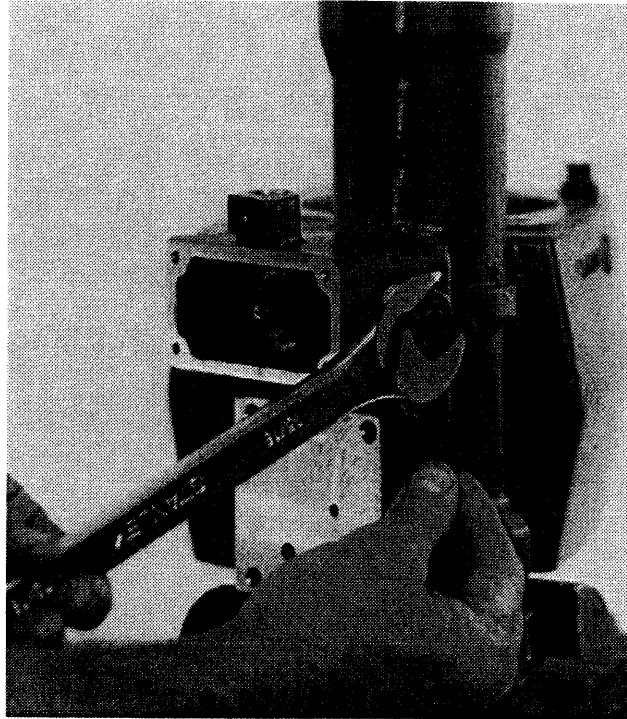

Step 15:

NOTE: Before you remove the check valve, carefully note its position. It should be reinstalled in the same position.

Loosen 15/16" locknut 1/4 turn. Use a 3/16" hex wrench to remove check valve assembly.

BREAKDOWN AND REASSEMBLY

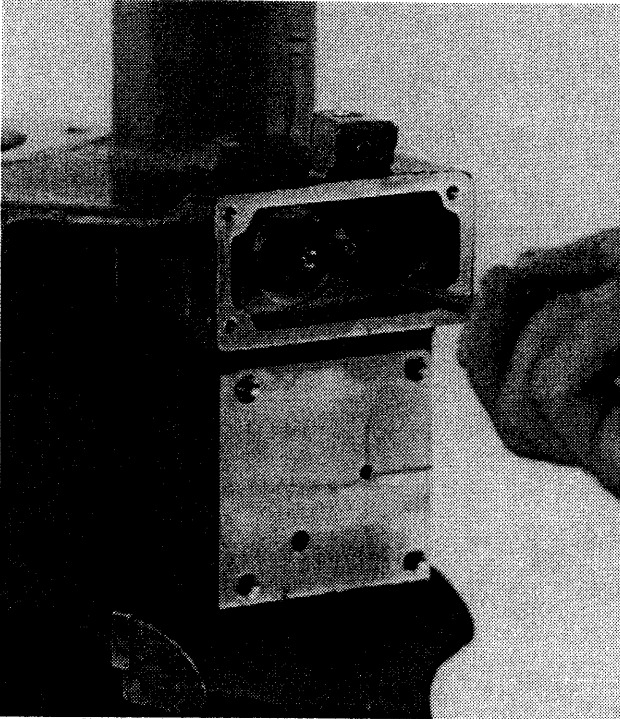

Step 16: Remove the retainer screw and the 3-way valve lever.

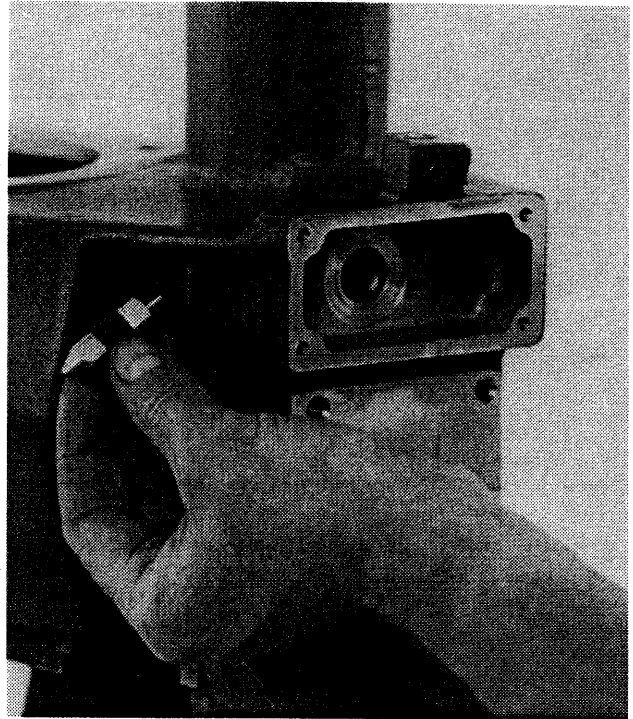

Step 18: Remove the shuttle by using a soft probe through the check valve opening, or by tipping housing forward. Notice that the tapered end of the shuttle is forward and the pin end is to the rear.

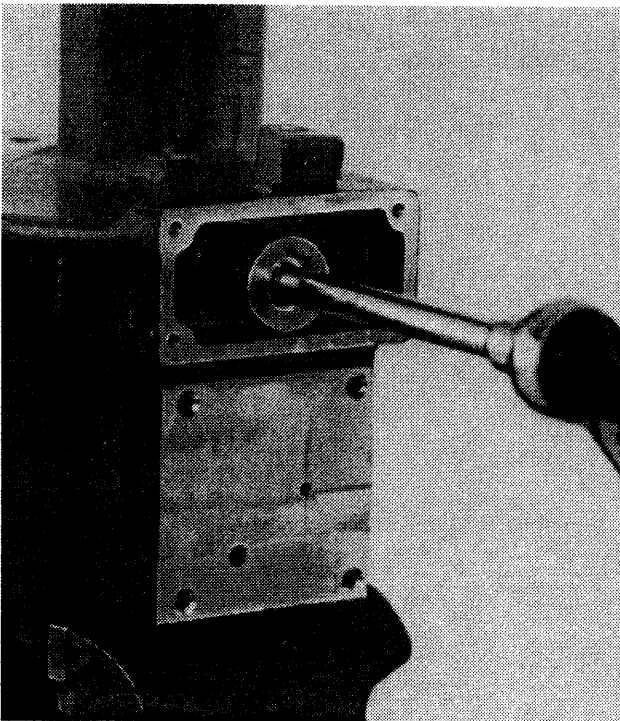

Step 17: Remove hub nut and camshaft assembly using a 7/8" socket. Inspect o-ring in camshaft stem. Replace if necessary.

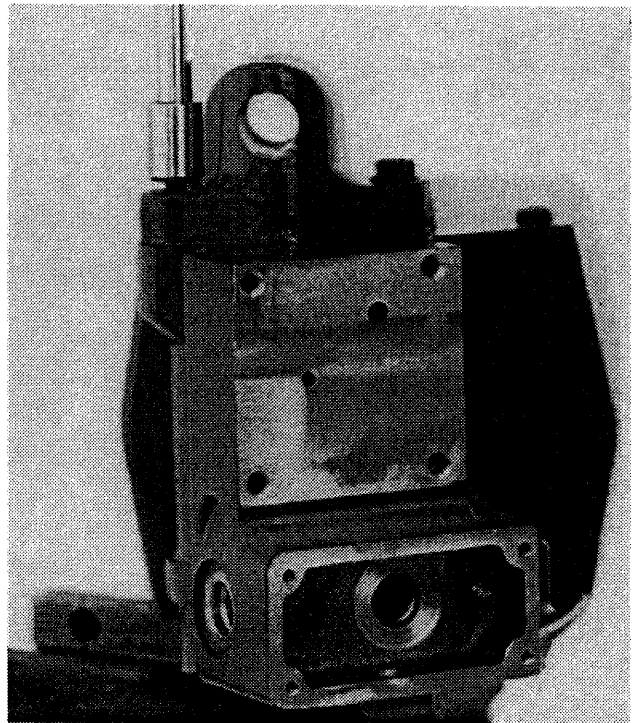

Step 19: Remove the base lug, using a 1/2" socket.

ISARMATIC® Mark IIIa - Cable

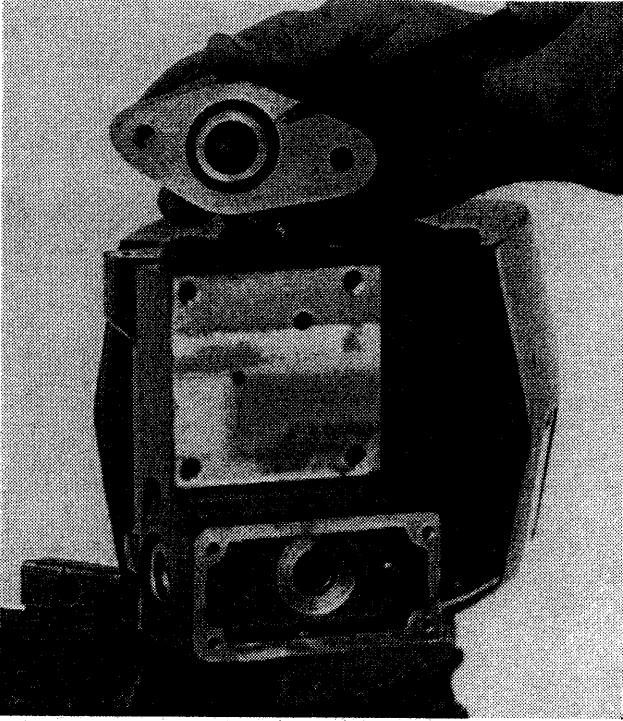

Step 20: Inspect mounting surface of base lug and housing for burrs or contamination and clean, if necessary. Install a new o-ring and reinstall the base lug with long flange to front. Torque to 195-205 in. lbs.

rear) and install camshaft assembly with cam lobe inserted in shuttle notch. Torque camshaft to 195-205 in. lbs.

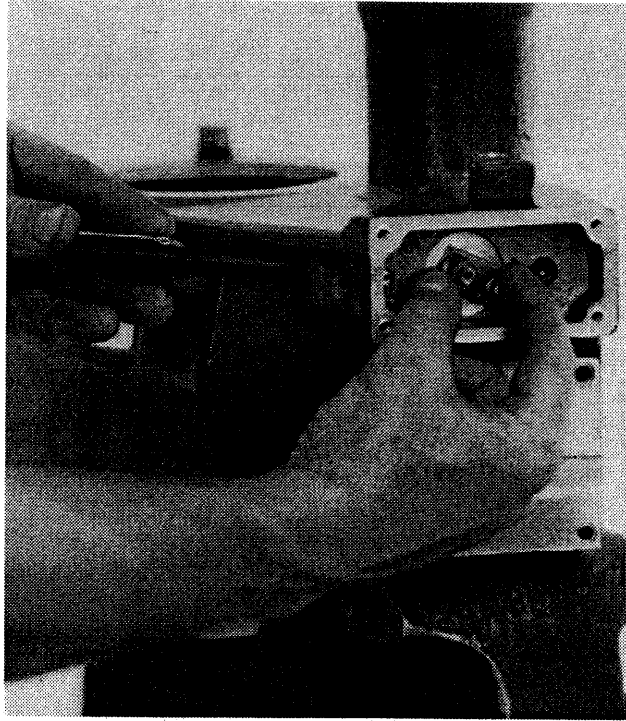

Step 22: Insert soft probe into lift valve port, resting probe against shuttle. Temporarily install valve lever. Rotate valve lever clockwise to verify that shuttle movement is towards lift valve. If shuttle movement is opposite, remove valve lever, rotate camshaft 180° and reinstall lever. Secure fasten valve lever with lock washer and screw.

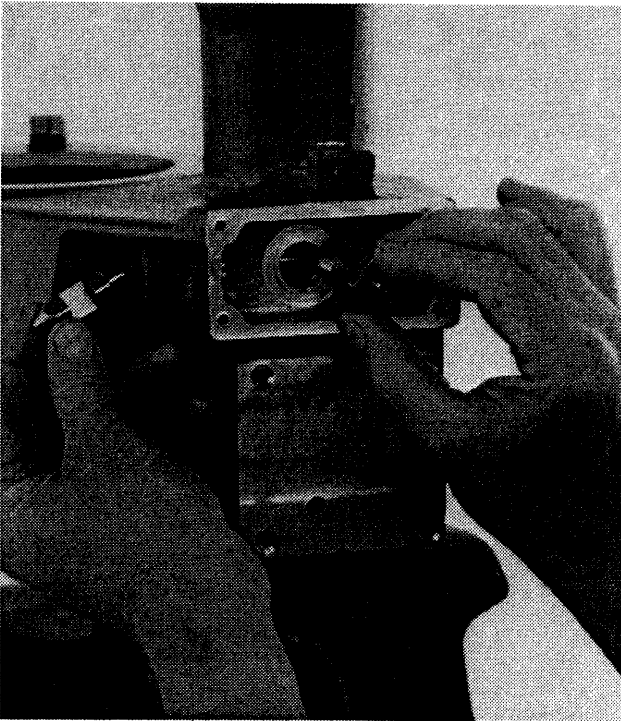

Step 21: Inspect 3-way porting and clean with solvent, if necessary. Insert and position shuttle (pin end to

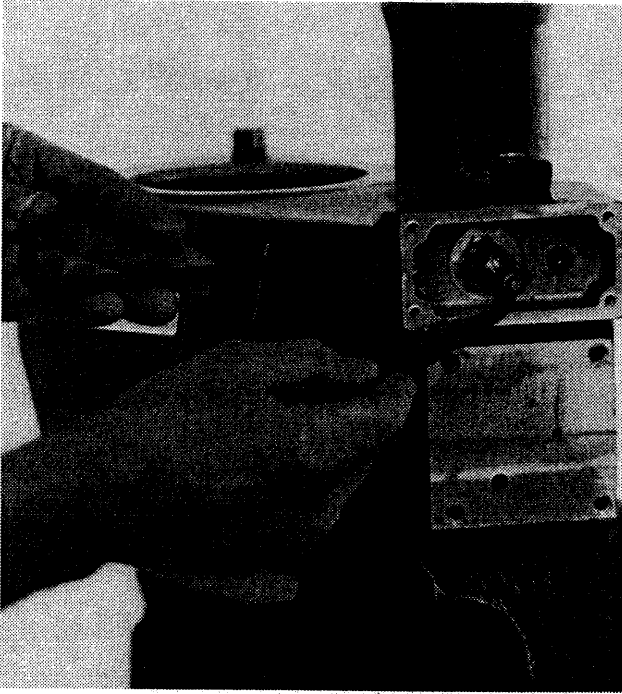

Step 23: Apply anti-seize compound to lift valve threads and lubricate o-rings with oil. Insert and adjust lift valve so the valve lever stops 1/16" to 1/8" before touching the bottom of the 3-way enclosure.

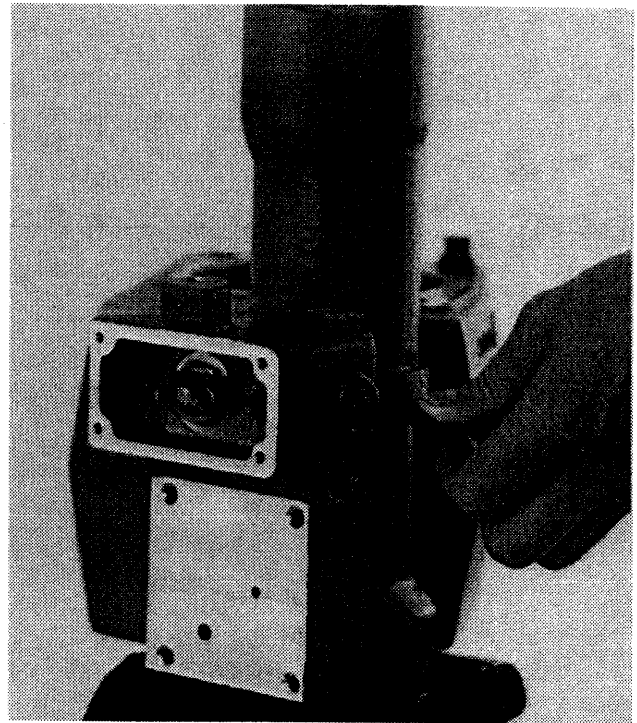

Step 24: Apply anti-seize compound to check valve threads and lubricate o-rings. Insert and adjust check valve to original position.

Optional adjustment:

Late Model: (Jam nut thickness = 3/8")
Threaded body of check valve will be **flush** with jam nut surface.

Pre-1989: (Jam nut thickness = 3/16") Two to three thread threads will **protrude beyond** jam nut surface.

Snug jam nut to 12 in-lb. to secure check valve in place.

ISARMATIC® Mark IIIa - Cable

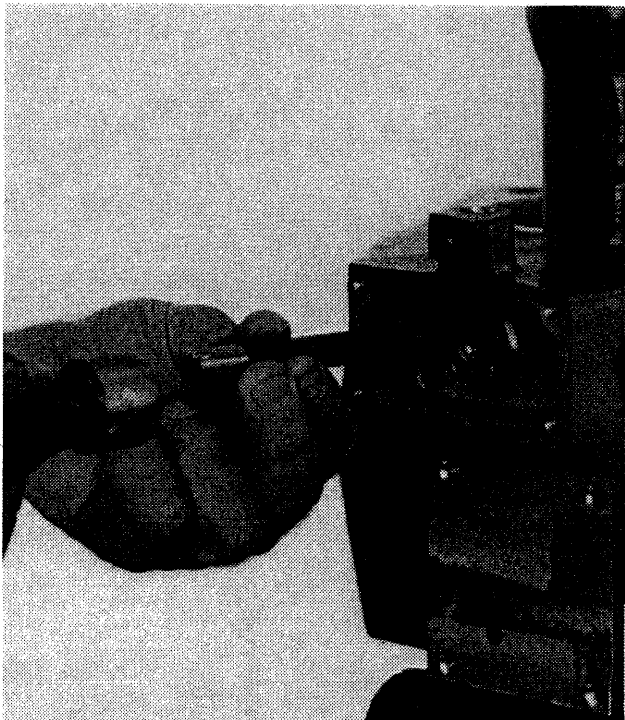

Step 25: If expansion plug is blown out or leaking, use a drift punch and hammer to install a new expansion plug.



Step 27: Remove and discard the old packing nut wiper. Install a new wiper.

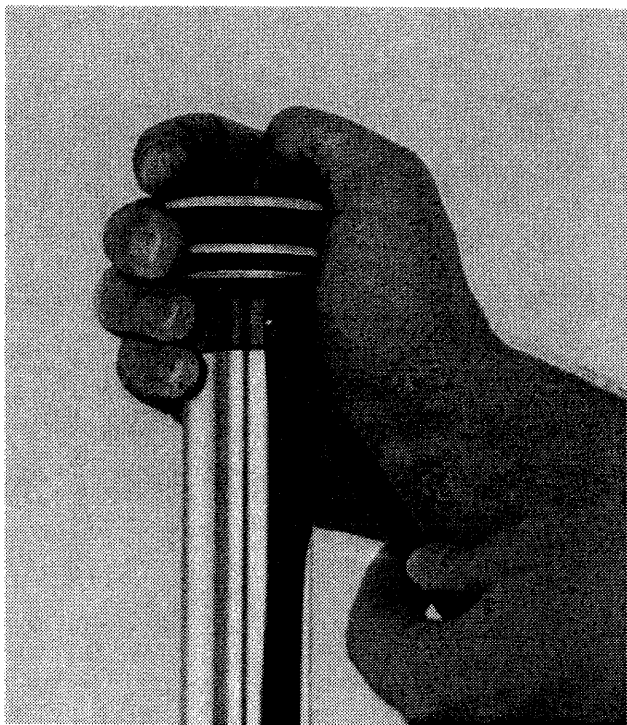

Step 26: Before installing a new packing set, file all burrs from around the 3/4" crosshole or plunger.

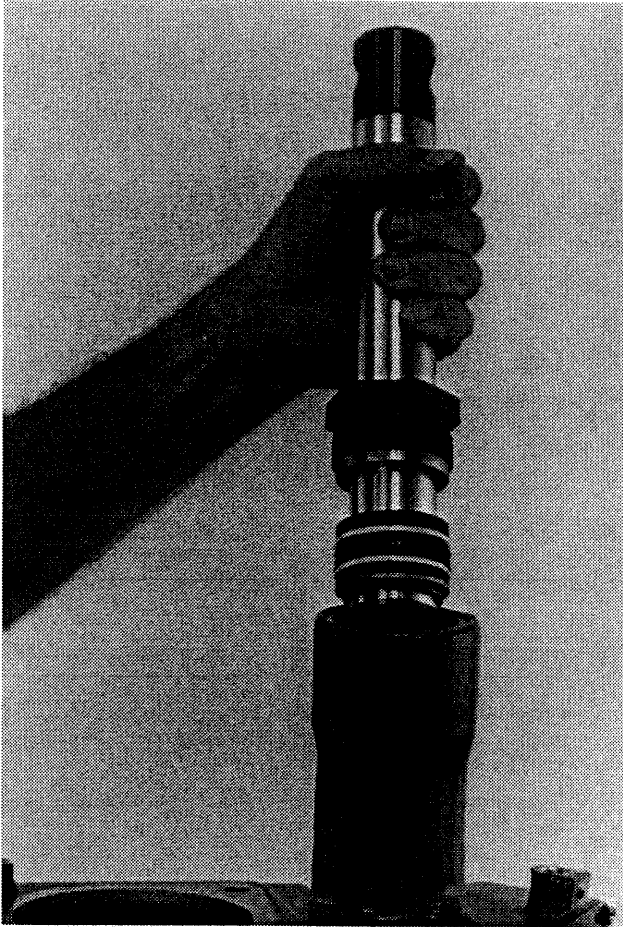

Step 28: Carefully install the plunger assembly into the lift cylinder.

NOTE: Be careful not to scratch or distort the packing set. Lubricate and gently push packing set into the lift cylinder with blunt screwdriver until all packings are beyond the cylinder threads. Apply anti-seize to packing nut threads and torque to 35 ft/lbs, which is approximately 1/4 turn passed hand-tight.

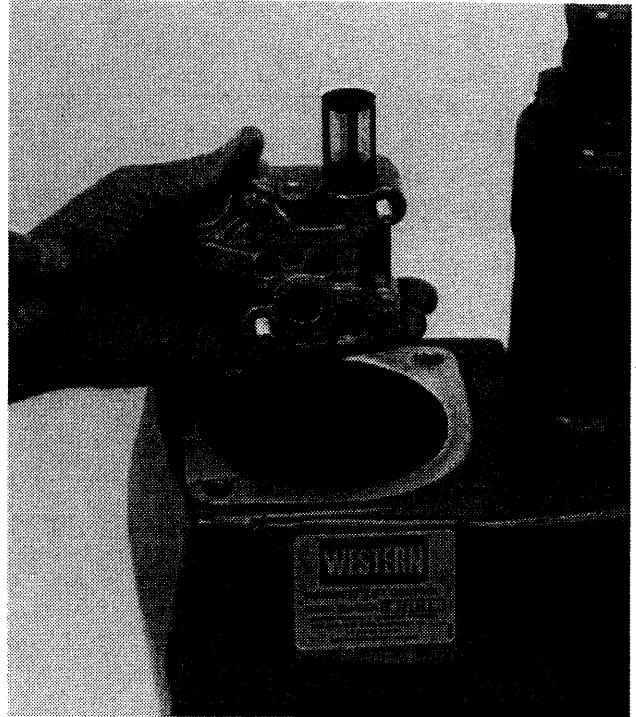

Step 29: Inspect mounting surface of pump and reservoir for burrs or contamination. Install new o-ring on pump.

ISARMATIC® Mark IIIa - Cable

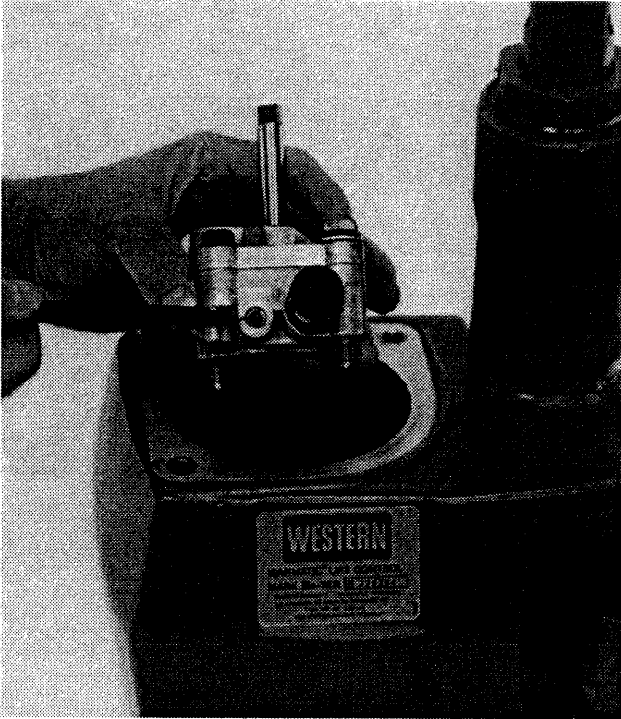

Step 30: If an increase to relief pressure is needed, rotate relief valve clockwise using a 3/16" hex wrench.

1/4 turn = 200 psi to 225 psi

Earlier Models: Relief valve is a slotted screw with jam nut.



Step 31: The pump must be installed with the filter to the front. The pump mounting bolts contain one flat and one spring washer. The high center of spring washer must be positioned against the bolt head.

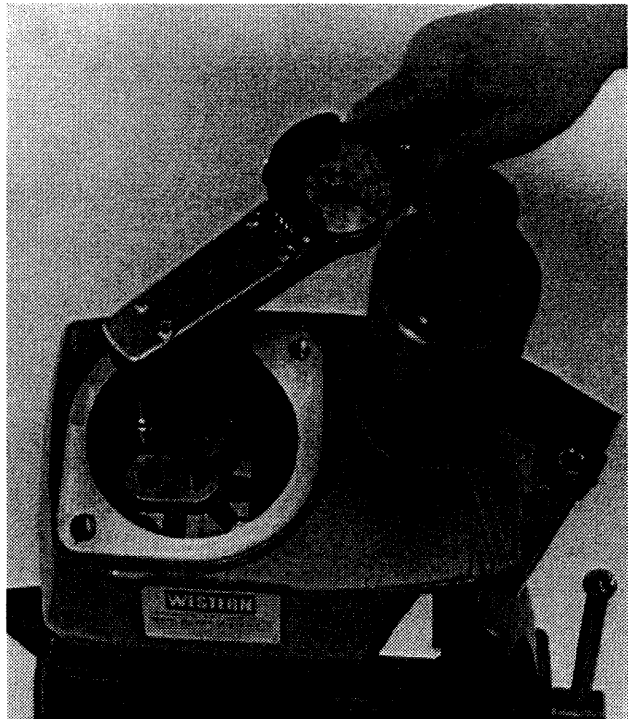

Step 32: Alternately tighten pump bolts by 50 in. lb. increments while rotating pump shaft. Torque to 175/185 in. lbs.

BREAKDOWN AND REASSEMBLY

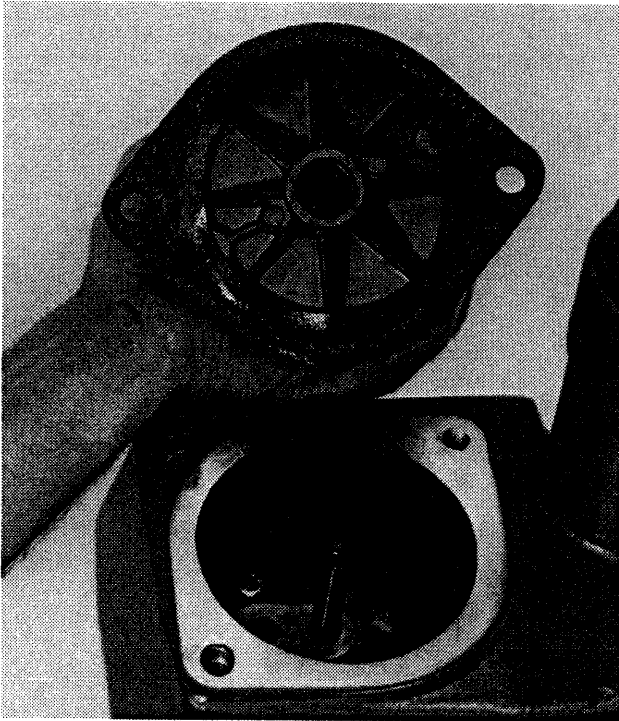

Step 33: Replace gasket on motor. Align drive slot of motor and drive tang of pump with mounting holes. Gently guide motor onto pump shaft, being careful not to damage motor seal. Torque motor bolts to 15/20 ft. lbs.

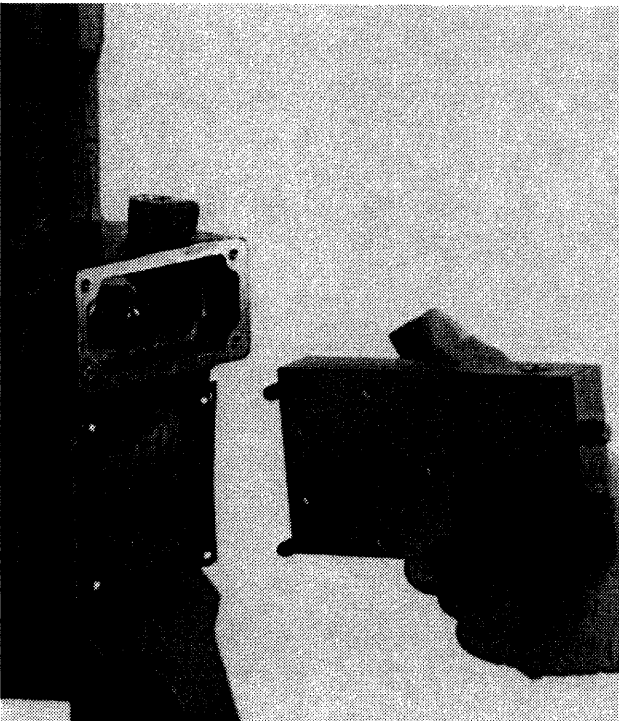

Step 34: Before reinstalling the 4-way valve assembly, inspect both mounting surfaces for burrs or

contamination. Replace worn or damaged o-rings. Apply a light coat of oil to hold the gasket and o-rings. Torque the mounting bolts to 100/130 in. lbs.

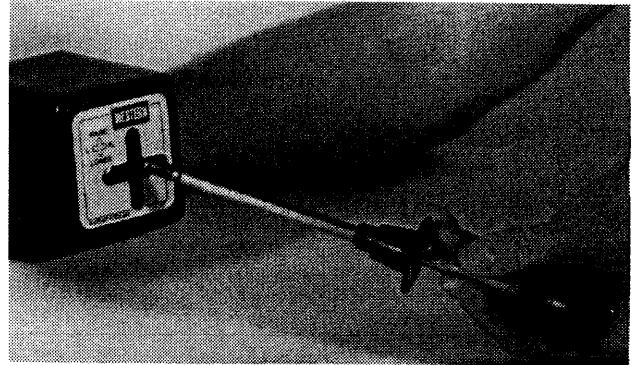

Step 35: Unscrew the lever assembly from the cab control box.

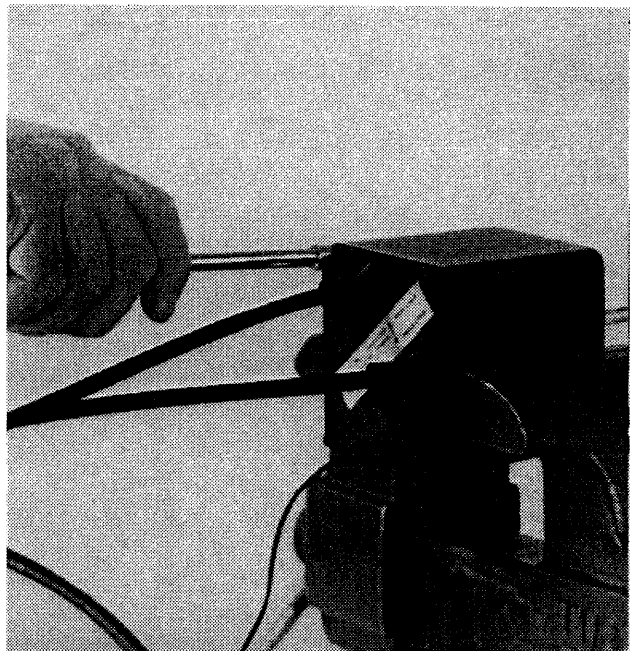

Step 36: Loosely clamp the control box in a vise and remove the four bottom cover screws.



WARNING: Control assembly contains compressed spring.

S 5-36

ISARMATIC® Mark IIIa - Cable

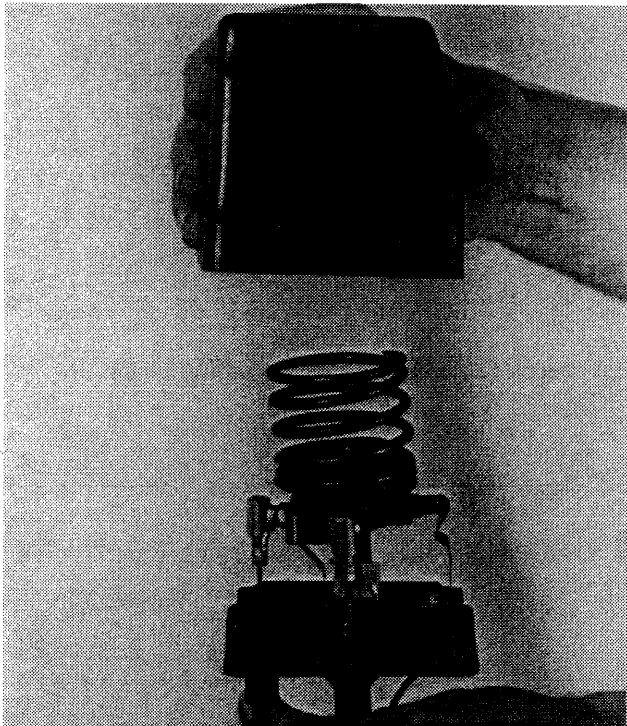

Step 37: Remove the body, spring, and spring seat from the bottom cover assembly.

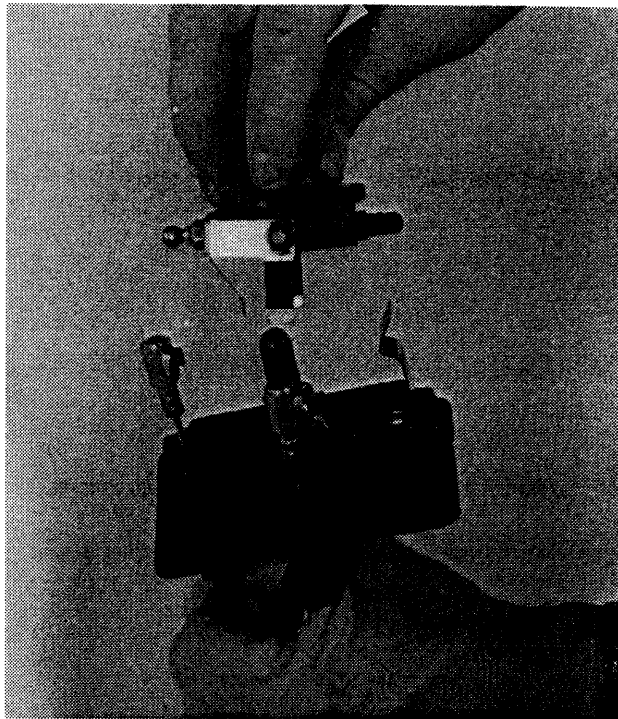

Step 39: Remove platen assembly. Apply graphite lubricant to center post and verify that contact tube assembly is properly seated to bottom of center post before reassembly.

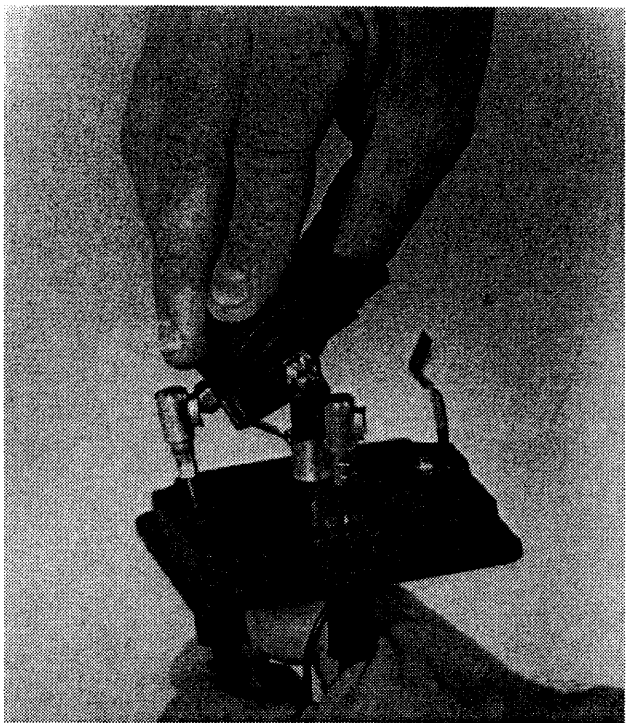

Step 38: Rotate platen assembly to unsnap from cables.



Step 40: Remove two ball studs and one screw to replace the contact strip.

BREAKDOWN AND REASSEMBLY



Step 41: Using pliers, lightly compress the tangs on the cable conduit snap fitting.

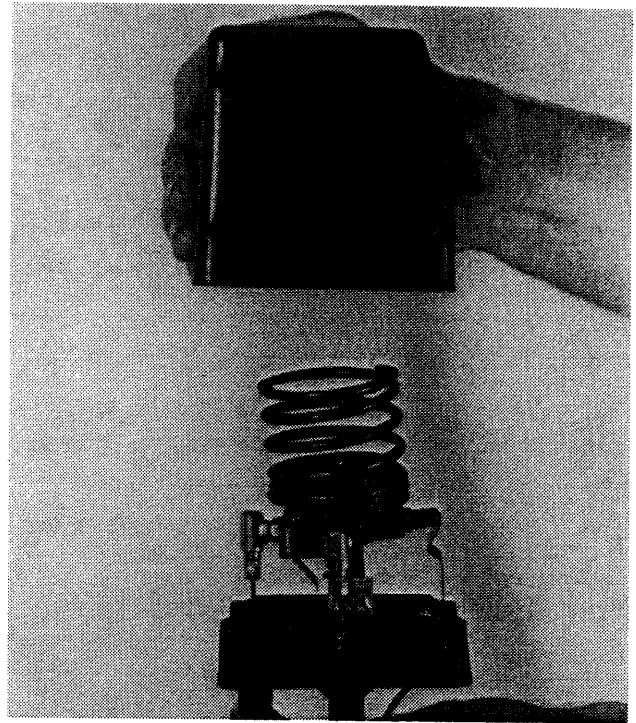

Step 43: Reassemble cab control in reverse order.



Step 42: Rock the snap fitting and carefully pull the cable downward.

ISARMATIC® Mark IIIa - Cable
